

Meteolabor EMP and Lightning Protection Devices



Release 2023

meteolabor

1.0 Catalog Index

1.0 Catalog Index	2
2.1 Representatives	4
2.2 Facts about EMP	6
2.3 Application	7
3.0 User Information	9
4.0 Data Sheets	12

Product	Page	Application	V _{Nom}	A _{Nom}	Band width	Phases
USS-1-C	13	Analog telephony	150V	0.5A	180kHz	
USS-1-6V	15	Data/Signal	6V	0.5A	300kHz	
USS-1-12V	17	Data/Signal	12V	0.5A	300kHz	
USS-1-15V	19	Data/Signal	15V	0.5A	300kHz	
USS-1-24V	21	Data/Signal	24V	0.5A	300kHz	
USS-1-48V	23	Data/Signal	48V	0.5A	200kHz	
USS-2-12V	27	Data/Signal/Power	12V	6A		
USS-2-24V	29	Data/Signal/Power	24V	6A		
USS-2-48V	31	Data/Signal/Power	48V	6A		
USS-2-C	33	Analog telephony	50V	6A	1MHz	
USS-2-3A-30V	35	Data/Signal	30V	3A	1MHz	
USS-2-250V-6A	37	Data/Signal	250V	6A	0.435 MHz	
USS-2-2048F	39	Digital telephony	150V	0.5A	2Mbps	
USS-2-AQ	41	Ethernet	3V		100Mbps	
USS-2-TV75-BNC	43	Video	2.5V	0.2A	30MHz	
USS-8	47	Data/Signal	8*150V	0.35A		
USS-48V-10SL-3-EMP	49	Power	56V	10A		
USS3x400/230V/16A/EMP/AC	51	Power	400V	16A		
USN-22001	55	VDSL/ADSL/ISDN	160V	0.25A	30 MHz	
USN-40001	57	Ethernet	3V		100 Mbps	
USN-40002	59	RS422/RS485	6V	0.1A	12Mbps	
USN-80001	61	Ethernet	3V		1 Gbps	
USN-80011	63	Ethernet	3V		1 Gbps	
USP-26101	67	Power	200V	32A		3
USP-34001	69	Power	230V	10A		1
USP-35001	71	Power	230V	16A		1
USP-35002	73	Power	230V	16A		1
USP-35004	75	Power	230V	16A		1
USP-35101	77	Power	230V	10A		1
USP-35102	79	Power	230V	16A		1
USP-35105	81	Power	230V	16A		1
USP-38101	83	Power	230V	63A		1
USP-47001	85	Power	400V	32A		3
USP-47101	87	Power	400V	32A		3
USP-47102	89	Power	400V	32A		3
USP-47103	91	Power	400V	25A		3
USP-47104	93	Power	400V	32A		3
USP-65001	95	Power	48V	16A		3
USP-75001	97	Power	24V	16A		
USP-75101	99	Power	24V	16A		
USP-99101	101	Power	14*48V	0.5A		
USP-99102	103	Power	14*48V	0.5A		



			Voltage	Current		Phases
PLP-34011	107	Power	400V	1000A		3
PLP-44011	109	Power	400V	1000A		3
PLP-44031	111	Power	400V	30A		3
PLP-44041	113	Power	400V	40A		3
PLP-44101	115	Power	400V	100A		3
PLP-44121	117	Power	400V	125A		3
PLP-44201	119	Power	400V	200A		3
PLP-44401	121	Power	400V	400A		3
PLP-44421	123	Power	230V	400A		1
PLP-44801	125	Power	400V	800A		3
PLP-FC-400-40-2	127	Power	400V	40A		3
PLP-FC-400-100	129	Power	400V	100A		3
PLP-FC-400-200	131	Power	400V	200A		3
Product		Application	Power	Band Width		
CSP-12101	135	RF	100W	0.11-0.5 GHz		
CSP-21102	137	RF	110W	0.23 GHz		
CSP-40101	139	RF	150W	DC-1 GHz		
CSP-40102	141	RF	150W	DC-1 GHz		
CSP-40103	143	RF	150W	DC-2.5 GHz		
CSP-41101	145	RF	60W	5.8 GHz		
CSP-41102	147	RF	60W	5.8 GHz		
CSP-42201	149	RF	100W	2 GHz		
CSP-43101	151	RF	300W	DC-1 GHz		
CSP-43102	153	RF	300W	DC-2.5 GHz		
CSP-44201	155	RF	150W	DC-2 GHz		
CSP-47101	157	RF	700W	DC-1 GHz		
CSP-55101	159	RF	500W	806-2500 MHz		
CSP-62101	161	RF	100W	6-18 GHz		
CSP-73101	163	RF	300W	2-6 GHz		
CSP-81101	165	RF	50W	DC+650-2500 MHz		
NKF-2A	168	Net command	230V/2A			
NKF-10A-LED	169	Net command	230V/10A			





Headquarter:
Meteolabor AG
Hofstrasse 92
CH-8620 Wetzikon
Switzerland

Tel. +41 / 44 / 934 40 40
info@meteolabor.ch
sales@meteolabor.ch
www.meteolabor.ch

Sales Office Germany:
Meteolabor Deutschland GmbH
Breslauer Strasse 23
DE-91083 Baiersdorf
Germany

Tel: +49-(0)9133-605372
info@meteolabor.de

2.1 Representatives

Austria Ing. E. Kubicek
Badnerstrasse 16
A - 2540 Bad Vöslau

Tel.: +43 664 150 44 01
edmund.kubicek@aon.at
www.firma-kubicek.at

China Beijing Wangda Shi Jia Technology
Development Ltd.
Room 5006,
Fengbaoheng Plaza,
No.1 Minzuyuan Road
Chaoyang District,
Beijing 100029

Tel.: +86 010-51660306-804
Fax: +86 010 82858412
sales16@wanddatech.com
www.nemp-china.com
www.wanddatech.com

Finland Finn Electric Oy
Fonseentintie 3
FI - 00370 Helsinki

Tel.: +358 9 8700 2721
info@finnelectric.fi
www.finnelectric.fi

France Comarel
Mr. Pierre-Yves Peirs
136, rue du 18 Juin
F - 95120 Ermont

Tel.: +33 1 34 13 7280
info@comarel.fr
www.comarel.fr

India Microtek Instruments
Mr. S. Mahendra Bothra
18 Lakshmanan Street
T. Nagar
600017 Chennai

Tel.: + 91 44 45960000
Fax: + 91 44 459 60025
microtek@airtelmail.com
www.microtekinstruments.com

India NOVA CBRN TECHNOLOGIES
PVT. LTD
Vivek Pawha
Corner House, 11-Qutab Road,
Ram Nagar
New Delhi - 110055

Tel: +91 98110 42397
vivek@novacbrn.com
www.novacbrn.com

Contact

Meteolabor AG
Hofstrasse 92
CH-8620 Wetzikon
Switzerland

Tel: +41 44 934 40 40

E-Mail: info@meteolabor.ch

Internet: www.meteolabor.ch

© by Meteolabor AG
All rights reserved

Content may change without further notice 2023-07
Representatives_e_V2023

2.1 Representatives

India	Rapic Codec Components Sri Divya Katneni #4031, Prestige W. Park, Jalahalli East, Gangamma C. Bangalore-560013	Tel : +91 80 23089408 info@rapidcodec.com www.rapidcodec.com
Japan	Nippon Automatic Control Comp. Hiroshi Sotobori 15F, Shin-Osaki Kangyo, BLDG 1-6-4, Osaki, Shinagawa-Ku Tokyo 141-0032	Tel: +81-3-5434-1600 Tel: +81-5434-1630 sotobori@naccjp.com
South Korea	WILL TECHNOLOGY Jong-il Park 261-2 Joobuk-Ri, Yangji-Myon, Yongin-Si, Gyunggi-Do 448-822, Korea	Tel: +82 31 332 6100 Tel: +82 32 322 6101 willteck@willteck.co.kr www.willteck.co.kr
Sweden	EMP-TRONIC AB Mr. Lars Günther Box 130 60 Edsvallabacken 12 SE-250 13 Helsingborg	Tel.: +46 42 23 5060 Fax: +46 42 23 5182 info@emp-tronic.se www.emp-tronic.se
Taiwan	Neat Technology Co., LTD. Andy Chi 11F, No.33, Ruyi St., Sanchong Dist, New Taipeh City Taiwan 241, R.O.C.	Tel: +886 2 82876441 Fax: +886 2 82872038 neattech@ms13.hinet.net www.neattech.com.tw
United Arab Emirates (GCC States)	Prime Marketing Consultancy P.O. Box 52506, Gulf Business Centre, Abdulla Bin Darwish Bldg. Abu Dhabi, UAE	Tel: +971 50 955 2057 prime@primemarkllc.ae
United Kingdom	APC Technology Group Ltd Barry Darwen 6 Stirling Park Laker Road Rochester Kent ME1 3QR	+44 7377549563 barry.darwen@apctech.com www.apctech.com
United States of America	Gemini Components, LLC David Hirschman 2 Emery Ave. Randolph, NJ 07869	Tel: +1 914 438 8075 dhirschman@geminielec.com www.geminielec.com

Contact

Meteolabor AG
Hofstrasse 92
CH-8620 Wetzikon
Switzerland

Tel: +41 44 934 40 40
Fax: +41 44 934 40 99
E-Mail: info@meteolabor.ch
Internet: www.meteolabor.ch

© by Meteolabor AG
All rights reserved

Content may change without further notice 2023-07
Representatives_e_V2023



What is an EMP?

An electromagnetic pulse originating from one of three possible sources:

- 1) An electromagnetic weapon attack. These weapons are no longer fiction; they are available to be used. They will take out infrastructures and systems such as computers, but they do not directly harm humans.
- 2) A nuclear device detonated in space, high above the earth. One nuclear weapon exploding in 40 km altitude is enough to cover whole Europe with an EMP-pulse capable of destroying most electronic devices.
- 3) Lightning or LEMP. This is the natural source of an EMP.

What happens after an EMP?

An EMP would presumably be far more catastrophic than a cyber attack. Every device that relies on integrated circuits could immediately be destroyed or its function seriously impaired. Studies have shown, that the failure of the equipment can happen so quickly, that affected computers do not even have an opportunity to log what happened. In fact, an EMP event is one of the greatest threats for data centers. There are studies indicating that two thirds of population would not survive the first year following an EMP attack, because the complete outage of the infrastructures may lead to starvation, disease, and societal collapse.

Do weapons or devices exist that generate an EMP which can be used on a small area like a building?

EMP weapons are already available. IEMI (Intentional Electromagnetic Interference weapons) can be purchased or assembled following instructions available on the Internet. Their dimensions range from fist size to a suitcase size up to a weapon which might be placed on a small trailer.

There are also military weapons, as the Boeing CHAMP (Counter-Electronics-High-Power-Advanced-Missile Project). This cruise missile weapon generates microwaves that can destroy the infrastructure of a building. So far it is known that the USA, China, Iran and North Korea have these weapons.

What sectors are at greatest risk?

- Defence
- Telecommunication
- Financial Services
- Security Services
- Power Plants
- Oil, Gas and Water supplies.

What can be done against the threat of an EMP?

There are two ways, an EMP can become dangerous:

- 1) **Over the air:** The electromagnetic waves penetrate the designated area through the air. The countermeasure is a Faraday cage. A metallic room, area, building, enclosure or even a suitcase does not allow the waves to pass. However, such Faraday enclosures must most often be accessible for humans and shielding problems start with the apertures (doors, windows) needed for this.
- 2) **Over the wire:** Mostly some sort of electronic equipment is used in the Faraday cage or shielded room. Equipment dependent on wire-bound power and/or signals. These signals enter the shielded room through apertures. WLAN is not applicable here. Outside the shielded room, the EMP field couples into the wires penetrating the Faraday Cage and may carry several thousand volt and ampere into the shielded area. Therefore all points of entry have to be protected with special equipment, protectors, capable of diverting this excess energy to ground.

EMP protection needs to be planned right from the beginning!

If EMP protection is only planned after an installation is already existing, it is either impossible or very expensive.

Do not only rely on MIL-STD-188-125 alone!

More and more organisations and even countries adopt EMP protection rules following MIL-STD-188-125. This is not sufficient! MIL-STD-188-125 is out-dated and unpractical. Although it is planned to be updated according to scientific and practical experience, this may take several years.

- 1) Shielding Effectiveness: This is the only area where the MIL-STD-188-125 is said to be appropriate.
- 2) Conducted Immunity: In the respective section of the MIL-STD-188-125 this is called PCI (Pulse current injection). Here, the standard is in the view of most experts too demanding.
- 3) The standard does not cover the mechanical shock waves associated with an atomic explosion in the atmosphere, there will also be a shock wave associated with the EMP.
- 4) The standard does not cover mechanical quality of the EMP protection filters. Is the device able to maintain the protection capability for a period of ten years under harsh conditions?
- 5) It does not cover data protection well enough. According to MIL-STD data lines must, when ever possible, enter the shielded area via fibre. Most data lines are, however, still not fibre connections.

Contact

Meteolabor AG
Hofstrasse 92
CH-8620 Wetzikon
Switzerland

Tel: +41 44 934 40 40
Fax: +41 44 934 40 99
E-Mail: info@meteolabor.ch
Internet: www.meteolabor.ch

2.3 Application

Standard EMP Protectors

METEOLABOR offers several product ranges. Common to all METEOLABOR filters is, that combined lightning and NEMP protection is guaranteed.

USS-1

Used for single wire, asymmetric power or data signals. Up to 150 V, 0.5 A and 180 kHz bandwidth.

USS-2

Used for wire pairs, symmetric power, telephony or data signals. Up to 150 V, 6 A and 100 MBits/s for Ethernet.

USN

Used for telephony, RS-485 or 1 Gbit / s Ethernet.

USP

Used for power lines up to 400 V / 64 A. Best suited for mobile installations.

PLP

Used for fixed installed power lines with up to 400V / 1000 A with weights up to 0.5 tons.

CSP

RF protectors, designed mainly for lightning protection, but offer also basic NEMP protection.

MAK

The modular solution for mobile and fixed use for shelters, trucks and tanks. With more than 70 different modules available.



Application: EMP Hardening of Data Centres

Today, most data centres are not protected against the threat of EMP. They will become ineffective in case of a NEMP or a microwave weapon like the Boeing Champ.

EMP weapons are a reality and no longer fiction. They will primarily take out the infrastructure without harming humans.

We serve as consultants for companies which are building data centres and want to implement the required protection technology.

EMP Testing

All our EMP protectors have passed through several stages of testing.

There is also one final inspection and electrical test on METEOLABOR's automatic testing system prior to released to the customers.

The automatic inspection system follows instructions programmed on a PC, fires a series of EMP pulses against the device, and logs the results.

But EMP protection must be planned right from the beginning. Implementing it later is almost impossible - the modifications to existing structures might be far too extensive.

EMP weapons are there. They will be used in the future by terrorists or by armed forces.



As of 2016 we started upgrading our devices from being threat level compliant to MIL-STD-188-125 (the whole system works after a NEMP) to 100% full single device compliance. This is more and more requested by our customers. To achieve this, we are using our own Montena E1 generator.

The picture shows a USP-74101 in final inspection test.



Contact

Meteolabor AG
Hofstrasse 92
CH-8620 Wetzikon
Switzerland

Tel: +41 (0)44 934 40 40
E-Mail: info@meteolabor.ch
Internet: www.meteolabor.ch

2.3 Application

Application: UAV Shelter

Unmanned aerial vehicles or drones UAVs need a ground station when in operation. Most of these ground stations offer space for two or more pilots, equipment and other staff.

It is in the nature of a UAV operation, that there must be bi-directional communication, computers and power.

All these signals can be protected, either by our standard products or the use of our MAK.

It does not matter, whether the shelter is mobile or stationary; we do have solutions for both versions.

Common is, that the components have a mechanical feed-through design to perfectly meet shielded room protection and filtering requirements.

With both versions, the implementation of the single entry principle can be maintained. This makes it possible to use standard instead of EMP hardened equipment in the shelter.



Application: EMP Truck or Tank Protection

Today a lot of tanks need full EMP protection, since they make use of many kinds of communication equipment and computers.

Meteolabors MAK (Modular Attachment Kit) provides full EMP protection for trucks, tanks and shelters.

Instead of having one big protection box, the MAK has many small protection boxes united in a common frame.

When a truck or tank is upgraded after a few years, the electronic requirements change as well. The MAK offers a modular solution, allowing any module to be exchanged while the complete box remains in place.

The MAK helps making safer investments for an often uncertain future. The demand changes.

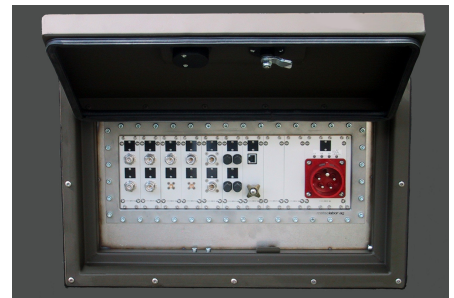

Application: High Speed Glider for High Altitude UAV Missions

A Swiss consortium, consisting of METEOLABOR as the prime contractor, Team Smartfish, EPFL and CSEM developed and successfully tested a high speed UAV glider travelling up to 32 km above ground and 1087 km/h speed.

The project was run by the ESA (European Space Agency). The goal was to make the final approach of re-entry vehicles (like the space shuttle) less prone to structural failure, GPS failure or power shortage.

The project was called iHMSD, integrated Health Management System Demonstrator and has many commercial applications.

In only 11 months, we have shown that flights at supersonic speed, at an altitude of 32 km and -70° C are possible with an 1.2 kg heavy glider, under harsh wind conditions.



Watch the movie related to the project on "youtube":
https://www.youtube.com/results?search_query=meteolabor+iHMSD

Contact

Meteolabor AG
Hofstrasse 92
CH-8620 Wetzikon
Switzerland

Tel: +41 (0)44 934 40 40
E-Mail: info@meteolabor.ch
Internet: www.meteolabor.ch

© Meteolabor AG, 2023
All Rights Reserved
application_e_V2023



Electromagnetic Compatibility at METEOLABOR AG

METEOLABOR was founded in 1965. From early on it has been active in two fields, Meteorological Instruments and Electromagnetic Compatibility. As automatic weather stations, meteorological sensors, and radar sounding equipment are often exposed to severe Electromagnetic Interference (EMI), we have been at the forefront of EMI-countermeasure development from the very beginning. METEOLABOR was among the first European companies to manufacture components for EMI mitigation:

- 1967: First power line and signal line filters.
- 1974: Lightning protection circuits for the grid of automatic weather stations and sensors of the Swiss Meteorological Service.
- 1978: First NEMP protection filters developed and NEMP tested together with METEOLABOR P-763 and P-760 radar equipment for the Swiss Army Weather Services.
- 2003: Modular Attachment Kits (MAK) for NEMP protection of military and civil vehicles.



Background: P-760, 400 MHz Radio Sounding System (Swiss Army Meteorological Service)
 Foreground (right): P-763, 1700 MHz Radio Sounding System (Swiss Army Artillery Meteorological Service)

HEMP Equipment Protection vs. Facility Protection

NEMP protection concepts for transportable, self-contained equipment and ground-based facilities differ in several aspects. For Equipment Protection it is assumed that sensitive parts are shielded against electromagnetic radiation and that internal components and circuits are built according to basic EMC design rules. Such measures may include 1 kV or 2 kV-tested isolation transformers for power and optical links for data input and output. The upgrade to lightning or HEMP compatibility is then done by adding Point of Entry full-power protection devices to the shield. All protection measures have to be carefully coordinated and it is necessary that all input and output specifications of the equipment are known in detail. Under such requirements it makes sense that residual signals of POE protective devices are defined as voltage and not as current. This protection philosophy leads to technically optimal and economically sound solutions.

For Facility Protection, it is assumed that site-internal power lines may be connected to the end user without galvanic separation (e.g. lighting installation, air conditioning system etc.), and that the neutral conductor may be grounded inside the facility. In such an environment, residual signals from the POE protection circuit or filter have to be defined as currents and not as voltages. It is further assumed that intra-site equipment may be exchanged at any time and that input/output specifications of such equipment may not be known in detail. This protection concept usually leads to practical but more expensive solutions.

METEOLABOR protection circuits or filters were originally designed for Equipment Protection (including NEMP tested military balloon-sounding radars for the Swiss Army, and equipment for other western military forces). All of our protective circuits have since been upgraded to MIL-STD-188-125 compliance or may be upgraded by adding designated upgrading circuitry on the protected side of the filters.

Standards, what they regulate and what they don't

MIL-STD 220 describes only measuring procedures and does not set minimum requirements for filters.

MIL-STD 188-125 1/2 sets minimum requirements for shielding effectiveness of entire facilities. Shielding effectiveness of components passing through the electromagnetic barrier (e.g. a filter) needs to be high enough not to lower the shielding effectiveness of the entire facility below the 100 dB, 14 kHz – 1 GHz threshold defined in MIL-STD-188-125. The standard does not specify insertion loss requirements for filters.

IEC 61000-2-10 describes the conducted disturbance environment of a HEMP and provides data and formulas for calculating E1, E2, and E3 peak currents for given line lengths. If line lengths are known and relatively short, this standard may allow the design of military level HEMP protection without fully complying with MIL-STD-188-125-1/2.

IEC 61000-4-24 describes methods for testing protective devices for HEMP conducted disturbance, including gas discharge tubes, varistors, and two-port SPDs, such as HEMP combination filters. It does not cover insertion loss measurement methods.

Line Categories in MIL-STD-188-125

The term Restricted Channel or Restricted Line is defined in FED-STD-1037 as a channel (or line) that has a useful capacity of only 56 kb/s (kilobits per second), instead of 64 kb/s in digital communications systems. As the line class (Restricted Line, Unrestricted Line etc.) has an influence on how filters are tested, it is important that the end-user specifies the line class and the number of penetrating conductors in the cable.

Contact

Meteolabor AG
 Hofstrasse 92
 CH-8620 Wetzikon
 Switzerland

Tel: +41 44 934 40 40
 E-Mail: info@meteolabor.ch
 Internet: www.meteolabor.ch

© by Meteolabor AG
 All rights reserved

Content may change without further notice 2023-07
 User Information_e_V2023



Protection against the E3 HEMP Component

MIL-STD-188-125-1 defines PCI (Pulse Current Injection) parameters for Inter-site Commercial Power Lines and Audio/Data Lines for the E1, E2, and E3 pulse. It does not, however, distinguish between high (>66 kV), medium (<33 kV), and low voltage (120 or 240 Vac) power lines. Because low voltage distribution lines can, for technical reasons, not be more than a few 100 m long, they cannot collect significant amounts of energy from the E3 pulse. IEC Standard 61000-2-10 (1998) gives data and formulas for calculating E1, E2, and E3 peak currents for given line lengths. E3 protection on 120/240 Vac end-user lines is unnecessary, because the voltage does not reach the threshold of voltage limiting arresters.

Threat Level Protection

We use the wording threat level tested in our datasheets. "Threat level tested" means, that independently of the kind of protection, the highest PCI currents according to MIL-STD-188-125 have been applied. The criteria to pass are, that the protector has not been Damaged (terminology of MIL188-125) and that the residual voltage is lower than what would be applied to the equipment during a CE standard surge/burst test. This ensures, that neither the protector nor the following equipment is damaged.

Full Compliant to MIL-STD-188-125

Full compliant protectors use the letters FC. For example our PLP-FC series is fully compliant to MIL-STD-188-125-1.

How much Insertion Loss should a NEMP-Filter have?

Ever since the late 1950s, when the danger of the NEMP as a weapon became evident, this question has caused confusion. The reason for the problem lies mainly in a misunderstanding about what MIL-STD-220 and MIL-STD-188-125-1 do and do not regulate. MIL-STD 220 describes insertion loss measuring procedures for high attenuation filters, but does not set minimum requirements. The most common misconception is that MIL-STD-188-125-1 requires a filter insertion loss of 100 dB between 14 kHz and 10 GHz. While MIL-STD 188-125-1 does in fact require the 100 dB for the overall radiation attenuation of an entire, fully equipped facility, it does not include any reference to filter insertion loss minimum requirements. The misconception is rooted in the belief that insertion loss of a filter and radiation attenuation of a shield are, because both are measured in dB, directly comparable entities and that the radiation attenuation of a shield would be compromised if the filter would have a lower insertion loss than 100 dB. To understand the dilemma, one has to understand the difference between conducted interference and radiated interference. The latter is easy to understand, especially if one considers an NEMP from a high altitude explosion (HEMP). The radiation attenuation

capture cross section of the unprotected line (length and type of installation, above ground or buried), 2) the surge-limiting capability of the arrester, 3) the insertion loss of the filter, and 4) the wiring layout inside the protected area (shielded or unshielded cables). It is obvious that knowing only the insertion loss of a filter is not enough to determine whether a conducted interference may pose a threat to equipment inside the shield. To eliminate this uncertainty, MIL-STD-188-125 not only sets a minimum requirement for radiation attenuation of the fully equipped facility but also maximum output currents under specified pulse current injections (short, intermediate, and long) into the arrester/filter combination.

Why not choose a filter with 100 dB from 14 kHz – 10 GHz in the first place? There are four reasons: 1) Filters with more than 40 - 60 dB at 14 kHz are using very large capacitors (up to hundreds of μF). Such filters draw high reactive currents and may short-circuit ripple control signals not only on the protected side but also in neighboring facilities, 2) If such capacitors are placed near the filter entrance (unprotected side) they may interfere with optimum performance of the surge arrester; 3) Such filters may also be unnecessarily large, heavy, and expensive; and 4) Experience shows that in the lower frequency range excessively high insertion loss is not necessary to fulfill the pulse current injection requirements of MIL-STD-188-125-1/2.

Contact

Meteolabor AG
Hofstrasse 92
CH-8620 Wetzikon
Switzerland

Tel: +41 44 934 40 40
E-Mail: info@meteolabor.ch
Internet: www.meteolabor.ch

© by Meteolabor AG
All rights reserved

Content may change without further notice 2023-07
User Information_e_V2023

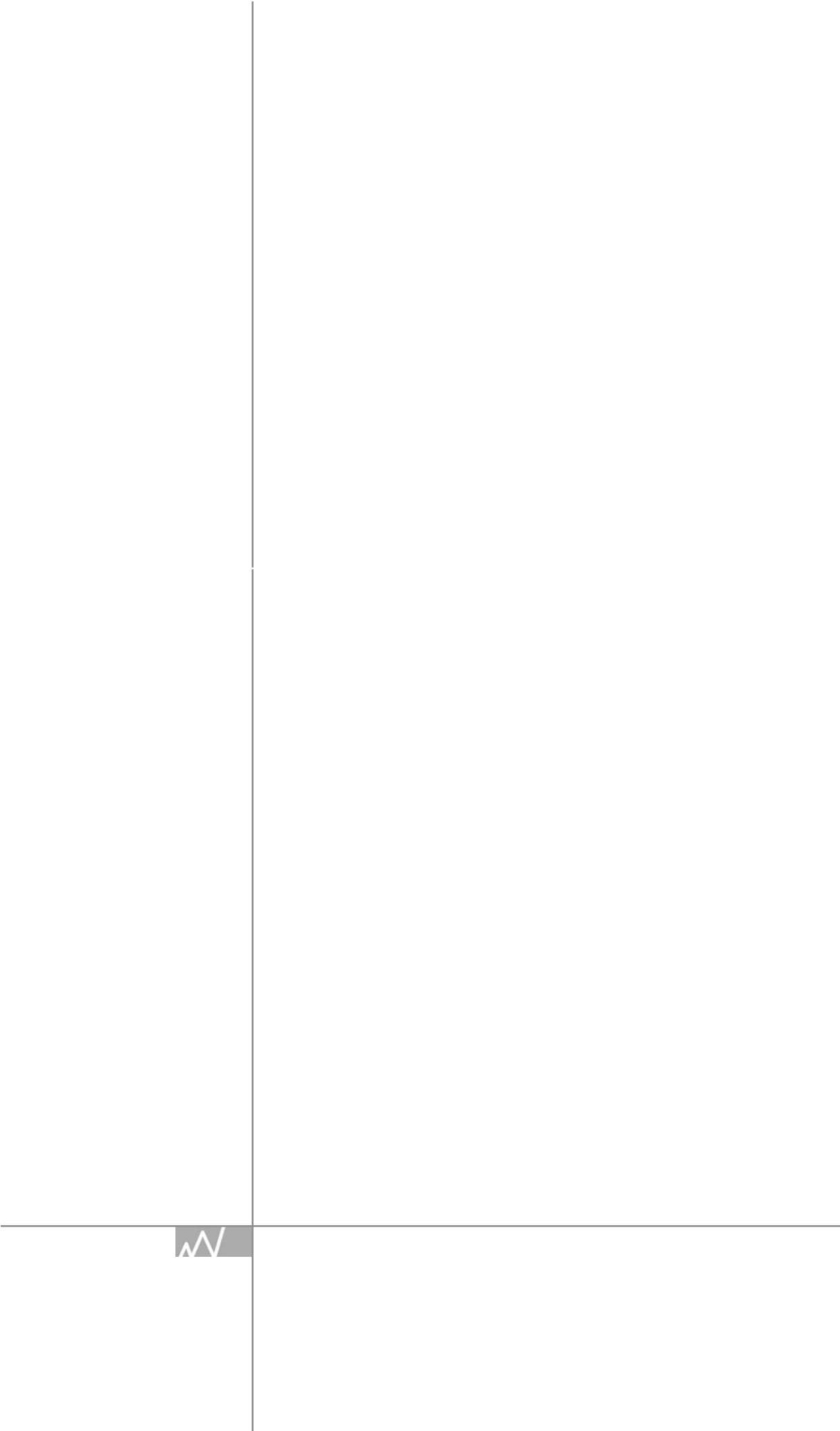



USS-1 Series

**Signal- / Dataline
Single Wire Protection**



meteolabor



EMP Surge Protector / Filter for Analog Telephone, Signal Lines USS-1-C

Effectively protects one wire of an analog telephone line or control signal

Protects against overvoltages produced by NEMP / HEMP, lightning or other transients

Coordinated multi-stage protection and filter designed for low residual voltages

High surge current capability

Threat-level tested against HEMP according to MIL-STD-188-125. For details see chapter "3 User Information"



Product

The Meteolabor USS-1 series overvoltage protector/filter elements consist of coordinated coarse and fine protection stages in combination with filtering components. This ensures best protection of sensitive equipment against very fast transient overvoltages (e.g. NEMP / HEMP). Surge currents up to 20 kA can be handled. In addition high frequency interferences are filtered efficiently within a wide range.

The unique mechanical design offers easy installation and compact fitting into Faraday cages, shielded rooms and mechanical enclosures. Single point of entry concepts can be simply realized to achieve best possible EMI behavior of penetrating feed-through elements.

Applications

The Meteolabor USS-1-C surge protector/filter is intended to protect one wire of an analog telephone line or control signals of sensitive telecom, sensor or other electronic equipment against destructive overvoltage effects caused by NEMP / HEMP or lightning strikes. USS-1-C is specially designed for analog 600 Ω telephone lines, it has a very low insertion loss in the frequency range of 300 – 3400 Hz.

USS-1-C has been used in many fixed installations (buildings, underground shelters etc.) as well as in portable and mobile systems like containers or shelters and vehicles, which were successfully EMP-tested on threat-level according to RS105 of MIL-STD-461F.

Technical Data USS-1-C

Application	Telephone, signal line	Analog telephone, signal below 100 kHz, protects one wire
Max. operating U_{Max} / I_{Max}	± 150 V DC / 0.5 A	$T_{amb} = 40^{\circ}\text{C}$, short-circuit current must be limited to 0.5 A
DC resistance	$< 5 \Omega$	
Insulation resistance	$> 1 \text{ G}\Omega$	wire → ground / case, @120 V measuring voltage
Max. surge current I_{Max}	20 kA	wire → ground / case, shape 8/20 μs
Max. lightning impulse current I_{Imp}	2 kA	Wire → ground / case, shape 10/350 μs, at least 1 pulse
DC sparkover voltage	230 V	Gas tube arrester, respect max. operating parameters for extinction
Residual voltage (surge 8/20 μs)	< 600 V	wire → ground / case, worst case depending on surge amplitude
Average common mode attenuation	typ. 50 dB	at 50 Ω, up to 1 GHz
Low pass cut-off frequency	180 kHz	3 dB
Insertion loss	typ. 0.15 dB	600 Ω measuring impedance, 300 – 3400 Hz
Operating temperature range	$- 40^{\circ}\text{C} / + 85^{\circ}\text{C}$	
Connection terminals	6.3 x 0.8 mm	Choice of FASTON flat receptacle, solder or screw connection
Case materials		Stainless steel: Hexagon sleeve (cage) and hex nut. Free cutting steel, nickel-plated: Threaded sleeve (cage)
Max. allowed installation torque	12 Nm	Not to be exceeded under all circumstances
Dimensions (Overall)	58 x 16 x 14 mm	details see reverse page
Weight	23 g	

Dimensions [mm]

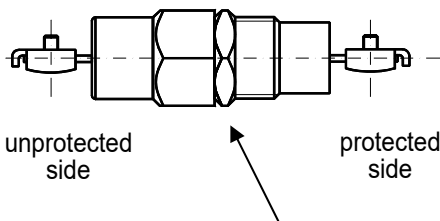
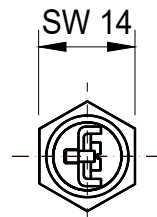
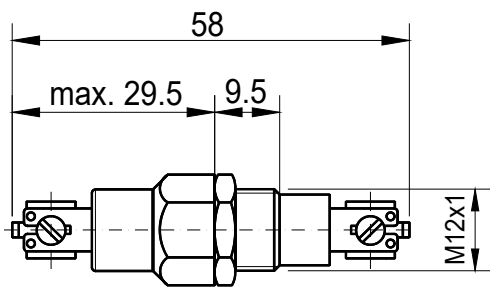

case / ground, torque max. 12 Nm

Installation Layouts

Standard drilling layout for USS-1 series with standard hexagonal nut (included, spanner size 14 mm)

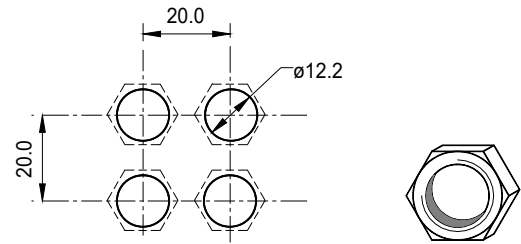

Space saving "honeycomb" mounting hole layout for USS-1 series (requires optional slotted nut USS-SM1 and USS-SK1 spanner)

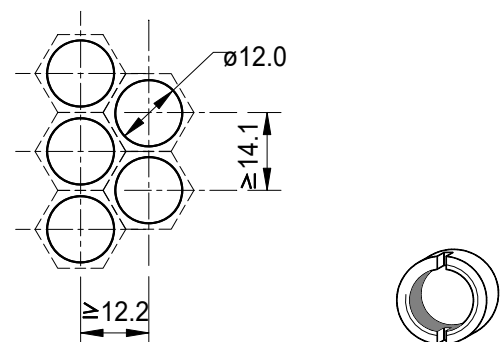

Installation Notes

- The USS-1 series EMP protector / filters shall be installed by electrically skilled personnel.
- The electrical wiring must be done according to local regulations.
- The max. values stated in this datasheet must not be exceeded under any circumstances.
- Do not exceed max. installation torque of 12 Nm as this can destroy the device.
- USS-1 series EMP protector / filters may be directly installed into the wall of a Faraday cage as feed-through device. Otherwise the cabling on the protected side must be shielded for best performance.
- For space-saving installation of multiple protectors a "honeycomb" layout is recommended (see drawings).

General Recommendations for Protection Installation

- In order to achieve the full performance of a protection circuit the application of good-practice EMC design techniques is necessary for the whole system to be protected.
- For EMP-protection usually a shield as an electromagnetic barrier to protect a certain volume is necessary. This shield avoids coupling of radiated disturbances inside the protected volume. In addition to shielding all penetrating wires must be protected from conducted transient interferences by an appropriate POE (point of entry) protection.
- Use tested, high quality POE (point of entry) protection elements for all wires entering an electromagnetic shield and install these as feed-through devices, e.g. the Meteolabor® USS-1, USS-2, USP, CSP or PLP series.

Ordering Information / Part Number

USS-1-C	Surge protector / filter EMP USS1-C
USS-SM1	2 pieces required for 1 telephone wire pair slotted nut (optional)
USS-SK1	special box-spanner for slotted nut (optional)



Caution

Maximum torque for installation screw shall not exceed 12 Nm

Contact

Meteolabor AG
Hofstrasse 92
CH-8620 Wetzikon
Switzerland

Tel: +41 44 934 40 40
E-Mail: info@meteolabor.ch
Internet: www.meteolabor.ch

Meteolabor AG
All rights reserved

Content may change without further notice 2023-05
USS-1-C_e_V2023

EMP Surge Protector / Filter for analog signals up to 6 V / 0.5 A USS-1-6V

Effectively protects one wire of an analog signal or control signal line

Protects against overvoltages produced by NEMP / HEMP, lightning or other transients

Coordinated multi-stage protection and filter designed for low residual voltages

High surge current capability

Feed-through type steel body for direct installation to wall of Faraday cage

Threat-level tested against HEMP according to MIL-STD-188-125. For details see chapter "3 User Information"



Product

The Meteolabor USS-1 series overvoltage protector / filter elements consist of coordinated coarse and fine protection stages in combination with filtering components. This ensures best protection of sensitive equipment against very fast transient overvoltages (e.g. NEMP / HEMP). Surge currents up to 20 kA can be handled. In addition high frequency interferences are filtered efficiently within a wide range.

The unique mechanical design offers easy installation and compact fitting into Faraday cages, shielded rooms and mechanical enclosures. Single point of entry concepts can be simply realized to achieve best possible EMI behavior of penetrating feed-through elements.

Applications

The Meteolabor USS-1-6 V surge protector / filter is intended to protect one wire of an analog signal or power line of grounded circuits up to 6 V / 0.5 A. It can be used for all kind of circuits to be protected against destructive overvoltage effects caused by NEMP / HEMP or lightning strikes. USS-1-6V has a typical bandwidth of 300 kHz and passes signals with a risetime of 1µs or higher.

USS-1-6 V has been used in many fixed installations (buildings, underground shelters etc.) as well as in portable and mobile systems like containers or shelters and vehicles, which were successfully EMP - tested on threat-level according to RS105 of MIL-STD-461F.

Technical Data USS-1-6V

Application	signal line	Analog signals up to 6 V / 0.5 A / 300 kHz, protects one wire
Maximum operating voltage U_{Max}	± 6.6 V DC	Absolute maximum values
Maximum operating current I_N	0.5 A	$T_{amb} = 40^\circ\text{C}$, short-circuit current must be limited to 0.5 A
DC resistance	$< 5 \Omega$	
Leakage current at U_{Max}	$< 60 \mu\text{A}$	Wire \rightarrow ground / case
Max. surge current I_{Max}	20 kA	Wire \rightarrow ground / case, shape 8 / 20 µs
Max. lightning impulse current I_{Imp}	2 kA	Wire \rightarrow ground/case, shape 10 / 350 µs, at least 1 pulse
Residual voltage (surge 8/20 µs)	< 12 V	wire \rightarrow ground / case, worst case depending on surge amplitude
Average attenuation	typ. 50 dB	at 50 Ω , up to 1 GHz
Low pass cut-off frequency	typ. 300 kHz	3 dB
Operating temperature range	- 40°C / + 85°C	
Connection terminals	6.3 x 0.8 mm	Choice of FASTON flat receptacle, solder or screw connection
Case materials		Stainless steel: Hexagon sleeve (cage) and hex nut. Free cutting steel, nickel-plated: Threaded sleeve (cage)
Max. allowed installation torque	12 Nm	Not to be exceeded under all circumstances
Dimensions (Overall)	58 x 16 x 14 mm	details see reverse page
Weight	23 g	

Dimensions [mm]

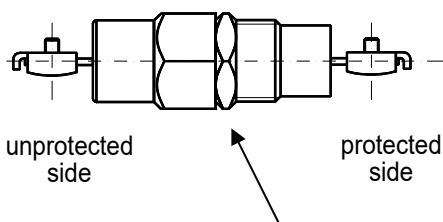
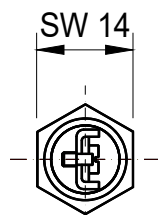
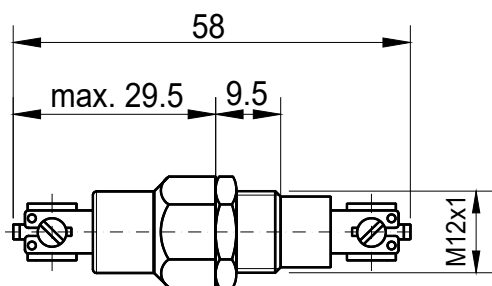

case / ground, torque max. 12 Nm

Installation Layouts

Standard drilling layout for USS-1 series with standard hexagonal nut (included, spanner size 14 mm)

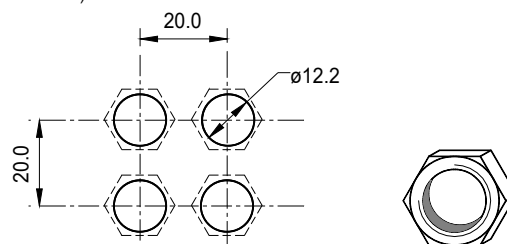

Space saving "honeycomb" mounting hole layout for USS-1 series (requires optional slotted nut USS-SM1 and USS-SK1 spanner)

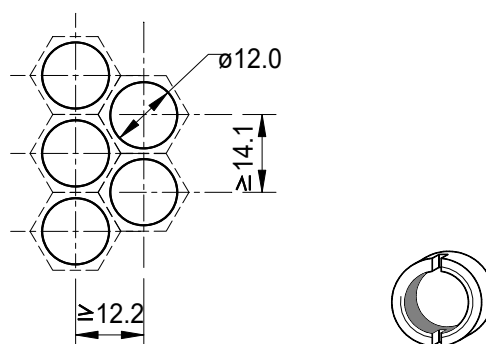

Installation Notes

- The USS-1 series EMP protector / filters shall be installed by electrically skilled personnel.
- The electrical wiring must be done according to local regulations.
- The max. values stated in this datasheet must not be exceeded under any circumstances.
- Do not exceed max. installation torque of 12 Nm as this can destroy the device.
- USS-1 series EMP protector / filters may be directly installed into the wall of a Faraday cage as feed-through device. Otherwise the cabling on the protected side must be shielded for best performance.
- For space-saving installation of multiple protectors a "honeycomb" layout is recommended (see drawings).

Ordering Information / Part Number

USS-1-6V	Surge protector / filter EMP USS1-6V 1 piece required per wire
USS-SM1	slotted nut (optional)
USS-SK1	special box-spanner for slotted nut (optional)

General Recommendations for Protection Installation

- In order to achieve the full performance of a protection circuit the application of good-practice EMC design techniques is necessary for the whole system to be protected.
- For EMP-protection usually a shield as an electromagnetic barrier to protect a certain volume is necessary. This shield avoids coupling of radiated disturbances inside the protected volume. In addition to shielding all penetrating wires must be protected from conducted transient interferences by an appropriate POE (point of entry) protection.
- Use tested, high quality POE (point of entry) protection elements for all wires entering an electromagnetic shield and install these as feed-through devices, e.g. the Meteolabor® USS-1, USS-2, USP, CSP or PLP series.



Caution

Maximum torque for installation screw shall not exceed 12 Nm

Contact

Meteolabor AG
Hofstrasse 92
CH-8620 Wetzikon
Switzerland

Tel: +41 44 934 40 40
E-Mail: info@meteolabor.ch
Internet: www.meteolabor.ch

© by Meteolabor AG
All rights reserved

Content may change without further notice 2023-07
USS-1-6V_e_V2023

EMP Surge Protector / Filter for analog signals up to 12 V / 0.5 A USS-1-12V

Effectively protects one wire of an analog signal or control signal line

Protects against overvoltages produced by NEMP / HEMP, lightning or other transients

Coordinated multi-stage protection and filter designed for low residual voltages

High surge current capability

Feed-through type steel body for direct installation to wall of Faraday cage

Threat-level tested against HEMP according to MIL-STD-188-125. For details see chapter "3 User Information"



Product

The Meteolabor USS-1 series overvoltage protector/filter elements consist of coordinated coarse and fine protection stages in combination with filtering components. This ensures best protection of sensitive equipment against very fast transient overvoltages (e.g. NEMP / HEMP). Surge currents up to 20 kA can be handled. In addition high frequency interferences are filtered efficiently within a wide range.

The unique mechanical design offers easy installation and compact fitting into Faraday cages, shielded rooms and mechanical enclosures. Single point of entry concepts can be simply realized to achieve best possible EMI behavior of penetrating feed-through elements.

Applications

The Meteolabor USS-1-12V surge protector / filter is intended to protect one wire of an analog signal or power line of grounded circuits up to 12 V / 0.5 A. It can be used for all kind of circuits to be protected against destructive overvoltage effects caused by NEMP / HEMP or lightning strikes. USS-1-12V has a typical bandwidth of 300 kHz and passes signals with a risetime of 1 μs or higher. USS-1-12V has been used in many fixed installations (buildings, underground shelters etc.) as well as in portable and mobile systems like containers or shelters and vehicles, which were successfully EMP-tested on threat-level according to RS105 of MIL-STD-461F.

Technical Data USS-1-12V

Application	signal line	Analog signals up to 12 V / 0.5 A / 300 kHz, protects one wire
Maximum operating voltage U_{Max}	± 13 V DC	Absolute maximum values
Maximum operating current I_N	0.5 A	$T_{amb} = 40^\circ\text{C}$, short-circuit current must be limited to 0.5 A
DC resistance	$< 5 \Omega$	
Leakage current at U_{Max}	$< 5 \mu\text{A}$	Wire \rightarrow ground / case
Max. surge current I_{Max}	20 kA	Wire \rightarrow ground / case, shape 8/20 μs
Max. lightning impulse current I_{Imp}	2 kA	Wire \rightarrow ground / case, shape 10/350 μs, at least 1 pulse
Residual voltage (surge 8/20 μs)	< 24 V	wire \rightarrow ground / case, worst case depending on surge amplitude
Average attenuation	typ. 50 dB	at 50 Ω, up to 1 GHz
Low pass cut-off frequency	typ. 300 kHz	3 dB
Operating temperature range	$- 40^\circ\text{C} / + 85^\circ\text{C}$	
Connection terminals	6.3 x 0.8 mm	Choice of FASTON flat receptacle, solder or screw connection
Case materials		Stainless steel: Hexagon sleeve (cage) and hex nut. Free cutting steel, nickel-plated: Threaded sleeve (cage)
Max. allowed installation torque	12 Nm	Not to be exceeded under all circumstances
Dimensions (Overall)	58 x 16 x 14 mm	details see reverse page
Weight	23 g	



Dimensions [mm]

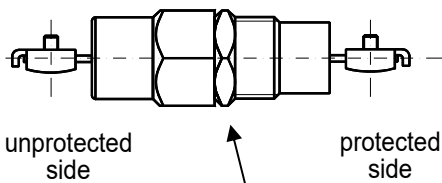
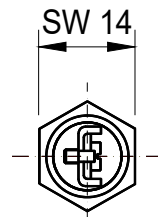
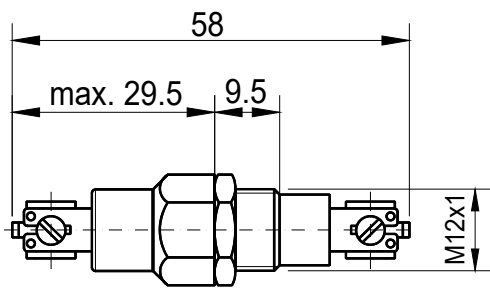

case / ground, torque max. 12 Nm

Installation Layouts

Standard drilling layout for USS-1 series with standard hexagonal nut (included, spanner size

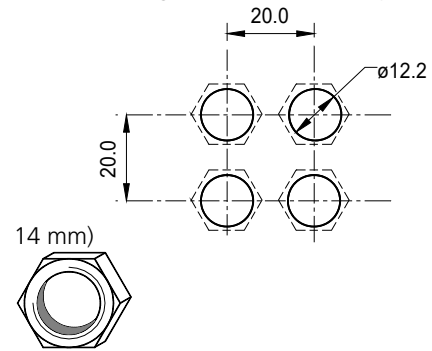

Space saving "honeycomb" mounting hole layout for USS-1 series (requires optional slotted nut USS-SM1 and USS-SK1 spanner))

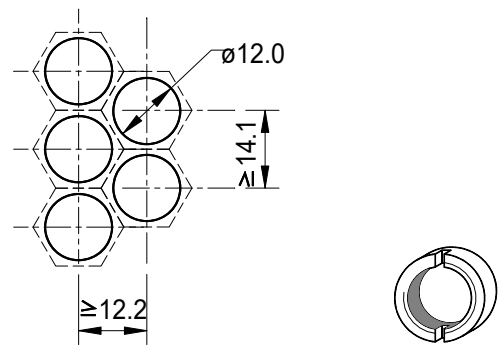

Installation Notes

- The USS-1 series EMP protector / filters shall be installed by electrically skilled personnel.
- The electrical wiring must be done according to local regulations.
- The max. values stated in this datasheet must not be exceeded under any circumstances.
- Do not exceed max. installation torque of 12 Nm as this can destroy the device.
- USS-1 series EMP protector / filters may be directly installed into the wall of a Faraday cage as feedthrough device. Otherwise the cabling on the protected side must be shielded for best performance.
- For space-saving installation of multiple protectors a "honeycomb" layout is recommended (see drawings).

Ordering Information / Part Number

- USS-1-12V** Surge protector / filter EMP USS1-12V
1 piece required per wire
- USS-SM1** slotted nut (optional)
- USS-SK1** special box-spanner for slotted nut (optional)

General Recommendations for Protection Installation

- In order to achieve the full performance of a protection circuit the application of good-practice EMC design techniques is necessary for the whole system to be protected.
- For EMP-protection usually a shield as an electromagnetic barrier to protect a certain volume is necessary. This shield avoids coupling of radiated disturbances inside the protected volume. In addition to shielding all penetrating wires must be protected from conducted transient interferences by an appropriate POE (point of entry) protection.
- Use tested, high quality POE (point of entry) protection elements for all wires entering an electromagnetic shield and install these as feed-through devices, e.g. the Meteolabor® USS-1, USS-2, USP, CSP or PLP series.



Caution

Maximum torque for installation screw shall not exceed 12 Nm

Contact

Meteolabor AG
Hofstrasse 92
CH-8620 Wetzikon
Switzerland

Tel: +41 44 934 40 40
E-Mail: info@meteolabor.ch
Internet: www.meteolabor.ch

© by Meteolabor AG
All rights reserved

Content may change without further notice 2023-07
USS-1-12V_e_V2023



EMP Surge Protector / Filter for analog signals up to 15 V / 0.5 A USS-1-15V

Effectively protects one wire of an analog signal or control signal line

Protects against overvoltages produced by NEMP / HEMP, lightning or other transients

Coordinated multi-stage protection and filter designed for low residual voltages

High surge current capability

Feed-through type steel body for direct installation to wall of Faraday cage

Threat-level tested against HEMP according to MIL-STD-188-125. For details see chapter "3 User Information"



Product

The Meteolabor USS-1 series overvoltage protector / filter elements consist of coordinated coarse and fine protection stages in combination with filtering components. This ensures best protection of sensitive equipment against very fast transient overvoltages (e.g. NEMP / HEMP). Surge currents up to 20 kA can be handled. In addition high frequency interferences are filtered efficiently within a wide range.

The unique mechanical design offers easy installation and compact fitting into Faraday cages, shielded rooms and mechanical enclosures. Single point of entry concepts can be simply realized to achieve best possible EMI behavior of penetrating feed-through elements.

Applications

The Meteolabor USS-1-15V surge protector / filter is intended to protect one wire of an analog signal or power line of grounded circuits up to 15 V / 0.5 A. It can be used for all kind of circuits to be protected against destructive overvoltage effects caused by NEMP / HEMP or lightning strikes. USS-1-15V has a typical bandwidth of 300 kHz and passes signals with a risetime of 1 μs or higher.

USS-1-15V has been used in many fixed installations (buildings, underground shelters etc.) as well as in portable and mobile systems like containers or shelters and vehicles, which were successfully EMP-tested on threat-level according to RS105 of MIL-STD-461F.

Technical Data USS-1-15V

Application	signal line	Analog signals up to 15 V / 0.5 A / 300 kHz, protects one wire
Maximum operating voltage U_{Max}	± 15 V DC	Absolute maximum values
Maximum operating current I_N	0.5 A	$T_{amb} = 40^\circ\text{C}$, short-circuit current must be limited to 0.5 A
DC resistance	$< 5 \Omega$	
Leakage current at U_{Max}	$< 5 \mu\text{A}$	Wire \rightarrow ground / case
Max. surge current I_{Max}	20 kA	Wire \rightarrow ground / case, shape 8/20 μs
Max. lightning impulse current I_{imp}	2 kA	Wire \rightarrow ground / case, shape 10/350 μs, at least 1 pulse
Residual voltage (surge 8/20 μs)	< 30 V	wire \rightarrow ground / case, worst case depending on surge amplitude
Average attenuation	typ. 50 dB	at 50 Ω, up to 1 GHz
Low pass cut-off frequency	typ. 300 kHz	3 dB
Operating temperature range	$- 40^\circ\text{C} / + 85^\circ\text{C}$	
Connection terminals	6.3 x 0.8 mm	Choice of FASTON flat receptacle, solder or screw connection
Case materials		Stainless steel: Hexagon sleeve (cage) and hex nut. Free cutting steel, nickel-plated: Threaded sleeve (cage)
Max. allowed installation torque	12 Nm	Not to be exceeded under all circumstances
Dimensions (Overall)	58 x 16 x 14 mm	details see reverse page
Weight	23 g	



Dimensions [mm]

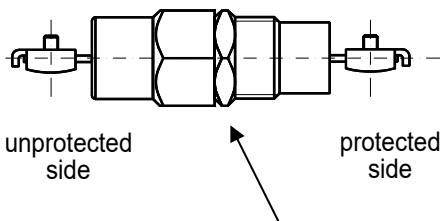
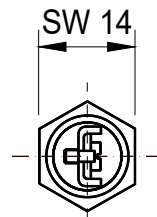
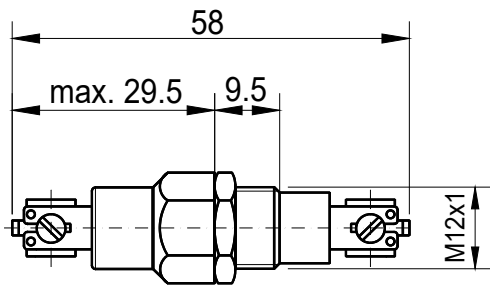

case / ground, torque max. 12 Nm

Installation Layouts

Standard drilling layout for USS-1 series with standard hexagonal nut (included, spanner size 14 mm)

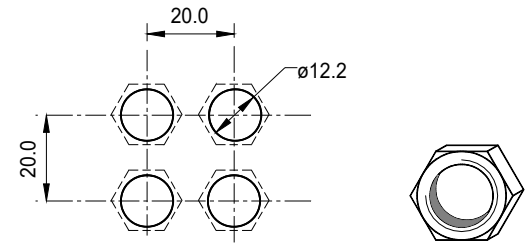

Space saving "honeycomb" mounting hole layout for USS-1 series (requires optional slotted nut USS-SM1 and USS-SK1 spanner)

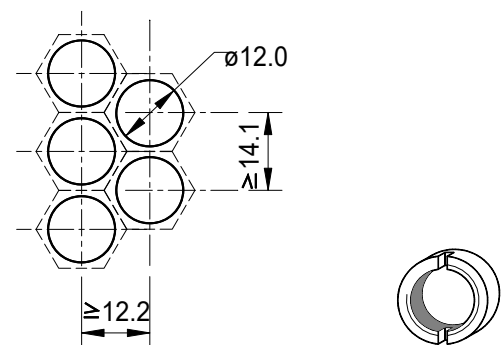

Installation Notes

- The USS-1 series EMP protector / filters shall be installed by electrically skilled personnel.
- The electrical wiring must be done according to local regulations.
- The max. values stated in this datasheet must not be exceeded under any circumstances.
- Do not exceed max. installation torque of 12 Nm as this can destroy the device.
- USS-1 series EMP protector / filters may be directly installed into the wall of a Faraday cage as feed-through device. Otherwise the cabling on the protected side must be shielded for best performance.
- For space-saving installation of multiple protectors a "honeycomb" layout is recommended (see drawings).

General Recommendations for Protection Installation

- In order to achieve the full performance of a protection circuit the application of good-practice EMC design techniques is necessary for the whole system to be protected.
- For EMP-protection usually a shield as an electromagnetic barrier to protect a certain volume is necessary. This shield avoids coupling of radiated disturbances inside the protected volume. In addition to shielding all penetrating wires must be protected from conducted transient interferences by an appropriate POE (point of entry) protection.
- Use tested, high quality POE (point of entry) protection elements for all wires entering an electromagnetic shield and install these as feed-through devices, e.g. the Meteolabor® USS-1, USS-2, USP, CSP or PLP series.

Ordering Information / Part Number

- USS-1-15V** Surge protector / filter EMP USS1-15V
1 piece required per wire
- USS-SM1** slotted nut (optional)
- USS-SK1** special box-spanner for slotted nut (optional)

Caution
Maximum torque for installation screw shall not exceed 12 Nm

Contact

Meteolabor AG
Hofstrasse 92
CH-8620 Wetzikon
Switzerland

Tel: +41 44 934 40 40
E-Mail: info@meteolabor.ch
Internet: www.meteolabor.ch

© by Meteolabor AG
All rights reserved

Content may change without further notice 2023-07
USS-1-15V_e_V2023

EMP Surge Protector / Filter for analog signals up to 24 V / 0.5 A USS-1-24V

Effectively protects one wire of an analog signal or control signal line

Protects against overvoltages produced by NEMP / HEMP, lightning or other transients

Coordinated multi-stage protection and filter designed for low residual voltages

High surge current capability

Feed-through type steel body for direct installation to wall of Faraday cage

Threat-level tested against HEMP according to MIL-STD-188-125. For details see chapter "3 User Information"



Product

The Meteolabor USS-1 series overvoltage protector/filter elements consist of coordinated coarse and fine protection stages in combination with filtering components. This ensures best protection of sensitive equipment against very fast transient overvoltages (e.g. NEMP / HEMP). Surge currents up to 20 kA can be handled. In addition high frequency interferences are filtered efficiently within a wide range.

The unique mechanical design offers easy installation and compact fitting into Faraday cages, shielded rooms and mechanical enclosures. Single point of entry concepts can be simply realized to achieve best possible EMI behavior of penetrating feed-through elements.

Applications

The Meteolabor USS-1-24V surge protector/filter is intended to protect one wire of an analog signal or power line of grounded circuits up to 24 V / 0.5 A. It can be used for all kind of circuits to be protected against destructive overvoltage effects caused by NEMP / HEMP or lightning strikes. USS-1-24V has a typical bandwidth of 300 kHz and passes signals with a risetime of 1 μs or higher.

USS-1-24V has been used in many fixed installations (buildings, underground shelters etc.) as well as in portable and mobile systems like containers or shelters and vehicles, which were successfully EMP-tested on threat-level according to RS105 of MIL-STD-461F.

Technical Data USS-1-24V

Application	signal line	Analog signals up to 24 V / 0.5 A / 300 kHz, protects one wire
Maximum operating voltage U_{Max}	± 28 V DC	Absolute maximum values
Maximum operating current I_N	0.5 A	$T_{amb} = 40^\circ\text{C}$, short-circuit current must be limited to 0.5 A
DC resistance	$< 5 \Omega$	
Leakage current at U_{Max}	$< 5 \mu\text{A}$	Wire \rightarrow ground / case
Max. surge current I_{Max}	20 kA	Wire \rightarrow ground / case, shape 8/20 μs
Max. lightning impulse current I_{imp}	2 kA	Wire \rightarrow ground / case, shape 10/350 μs, at least 1 pulse
Residual voltage (surge 8/20 μs)	< 48 V	wire \rightarrow ground / case, worst case depending on surge amplitude
Average attenuation	typ. 45 dB	at 50 Ω, up to 1 GHz
Low pass cut-off frequency	typ. 300 kHz	3 dB
Operating temperature range	$- 40^\circ\text{C} / + 85^\circ\text{C}$	
Connection terminals	6.3 x 0.8 mm	Choice of FASTON flat receptacle, solder or screw connection
Case materials		Stainless steel: Hexagon sleeve (cage) and hex nut. Free cutting steel, nickel-plated: Threaded sleeve (cage)
Max. allowed installation torque	12 Nm	Not to be exceeded under all circumstances
Dimensions (Overall)	58 x 16 x 14 mm	details see reverse page
Weight	23 g	



Dimensions [mm]

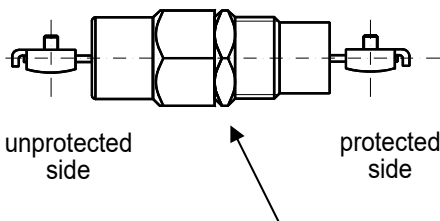
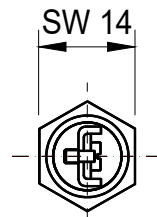
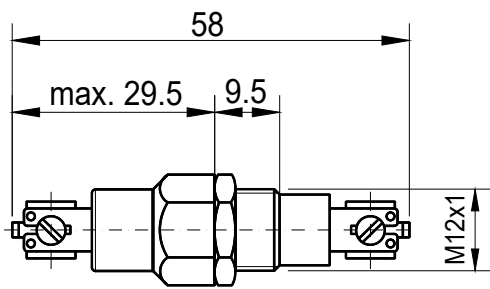

case / ground, torque max. 12 Nm

Installation Layouts

Standard drilling layout for USS-1 series with standard hexagonal nut (included, spanner size 14 mm)

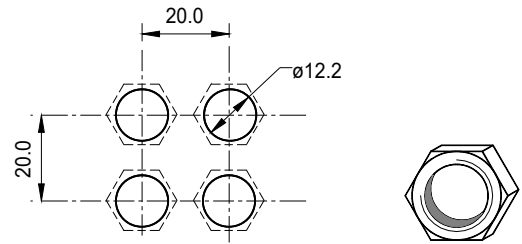

Space saving "honeycomb" mounting hole layout for USS-1 series (requires optional slotted nut USS-SM1 and USS-SK1 spanner)

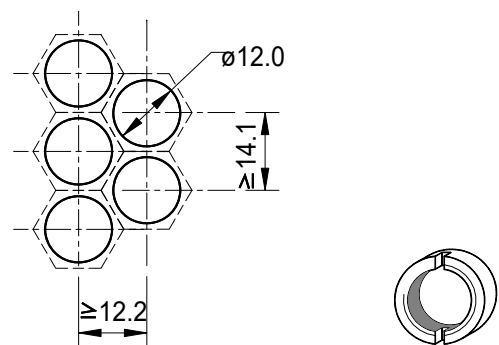

Installation Notes

- The USS-1 series EMP protector / filters shall be installed by electrically skilled personnel.
- The electrical wiring must be done according to local regulations.
- The max. values stated in this datasheet must not be exceeded under any circumstances.
- Do not exceed max. installation torque of 12 Nm as this can destroy the device.
- USS-1 series EMP protector / filters may be directly installed into the wall of a Faraday cage as feed-through device. Otherwise the cabling on the protected side must be shielded for best performance.
- For space-saving installation of multiple protectors a "honeycomb" layout is recommended (see drawings).

General Recommendations for Protection Installation

- In order to achieve the full performance of a protection circuit the application of good-practice EMC design techniques is necessary for the whole system to be protected.
- For EMP-protection usually a shield as an electromagnetic barrier to protect a certain volume is necessary. This shield avoids coupling of radiated disturbances inside the protected volume. In addition to shielding all penetrating wires must be protected from conducted transient interferences by an appropriate POE (point of entry) protection.
- Use tested, high quality POE (point of entry) protection elements for all wires entering an electromagnetic shield and install these as feed-through devices, e.g. the Meteolabor® USS-1, USS-2, USP, CSP or PLP series.

Ordering Information / Part Number

- USS-1-24V** Surge protector / filter EMP USS1-24V
1 piece required per wire
- USS-SM1** slotted nut (optional)
- USS-SK1** special box-spanner for slotted nut (optional)

Caution
Maximum torque for installation screw shall not exceed 12 Nm

Contact

Meteolabor AG
Hofstrasse 92
CH-8620 Wetzikon
Switzerland

Tel: +41 44 934 40 40
E-Mail: info@meteolabor.ch
Internet: www.meteolabor.ch

© by Meteolabor AG
All rights reserved

Content may change without further notice 2023-07
USS-1-24V_e_V2023



EMP Surge Protector / Filter for analog signals up to 48 V / 0.5 A USS-1-48V

Effectively protects one wire of an analog signal or control signal line

Protects against overvoltages produced by NEMP / HEMP, lightning or other transients

Coordinated multi-stage protection and filter designed for low residual voltages

High surge current capability

Feed-through type steel body for direct installation to wall of Faraday cage

Threat-level tested against HEMP according to MIL-STD-188-125. For details see chapter "3 User Information"



Product

The Meteolabor USS-1 series overvoltage protector / filter elements consist of coordinated coarse and fine protection stages in combination with filtering components. This ensures best protection of sensitive equipment against very fast transient overvoltages (e.g. NEMP / HEMP). Surge currents up to 20 kA can be handled. In addition high frequency interferences are filtered efficiently within a wide range.

The unique mechanical design offers easy installation and compact fitting into Faraday cages, shielded rooms and mechanical enclosures. Single point of entry concepts can be simply realized to achieve best possible EMI behavior of penetrating feed-through elements.

Applications

The Meteolabor USS-1-48V surge protector / filter is intended to protect one wire of an analog signal or power line of grounded circuits up to 48 V / 0.5 A. It can be used for all kind of circuits to be protected against destructive overvoltage effects caused by NEMP / HEMP or lightning strikes. USS-1-48V has a typical bandwidth of 300 kHz and passes signals with a risetime of 1 μs or higher.

USS-1-48V has been used in many fixed installations (buildings, underground shelters etc.) as well as in portable and mobile systems like containers or shelters and vehicles, which were successfully EMP-tested on threat-level according to RS105 of MIL-STD-461F.

Technical Data USS-1-48V

Application	signal line	Analog signals up to 48 V / 0.5 A / 300 kHz, protects one wire
Maximum operating voltage U_{Max}	± 58 V DC	Absolute maximum values
Maximum operating current I_N	0.5 A	$T_{amb} = 40^\circ\text{C}$, short-circuit current must be limited to 0.5 A
DC resistance	$< 5 \Omega$	
Leakage current at U_{Max}	$< 5 \mu\text{A}$	Wire \rightarrow ground / case
Max. surge current I_{Max}	20 kA	Wire \rightarrow ground / case, shape 8/20 μs
Max. lightning impulse current I_{imp}	2 kA	Wire \rightarrow ground / case, shape 10/350 μs, at least 1 pulse
Residual voltage (surge 8/20 μs)	< 120 V	wire \rightarrow ground / case, worst case depending on surge amplitude
Average attenuation	typ. 45 dB	at 50 Ω, up to 1 GHz
Low pass cut-off frequency	typ. 300 kHz	3 dB
Operating temperature range	$- 40^\circ\text{C} / + 85^\circ\text{C}$	
Connection terminals	6.3 x 0.8 mm	Choice of FASTON flat receptacle, solder or screw connection
Case materials		Stainless steel: Hexagon sleeve (cage) and hex nut. Free cutting steel, nickel-plated: Threaded sleeve (cage)
Max. allowed installation torque	12 Nm	Not to be exceeded under all circumstances
Dimensions (Overall)	58 x 16 x 14 mm	details see reverse page
Weight	23 g	



Dimensions [mm]

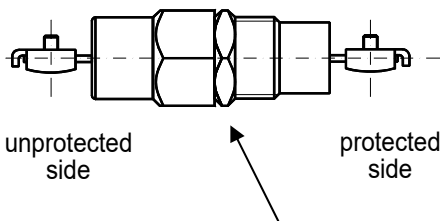
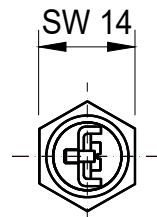
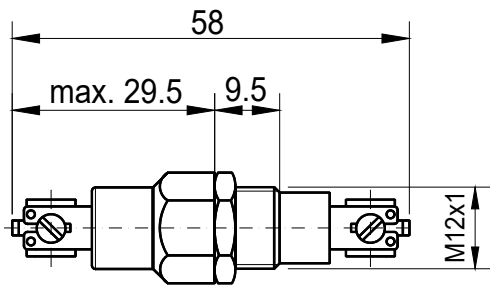

case / ground, torque max. 12 Nm

Installation Layouts

Standard drilling layout for USS-1 series with standard hexagonal nut (included, spanner size 14 mm)

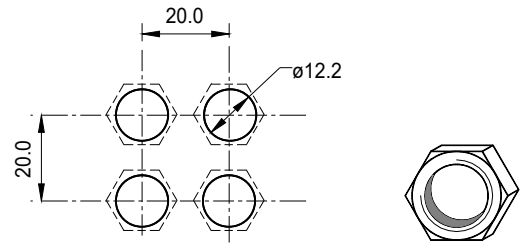

Space saving "honeycomb" mounting hole layout for USS-1 series (requires optional slotted nut USS-SM1 and USS-SK1 spanner)

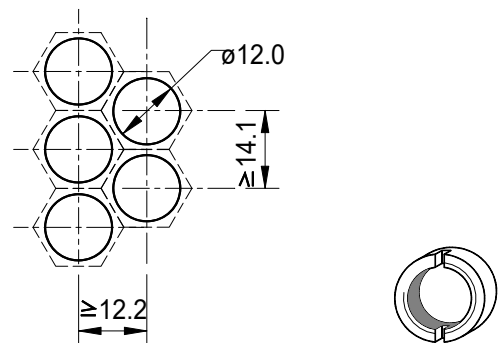

Installation Notes

- The USS-1 series EMP protector / filters shall be installed by electrically skilled personnel.
- The electrical wiring must be done according to local regulations.
- The max. values stated in this datasheet must not be exceeded under any circumstances.
- Do not exceed max. installation torque of 12 Nm as this can destroy the device.
- USS-1 series EMP protector / filters may be directly installed into the wall of a Faraday cage as feed-through device. Otherwise the cabling on the protected side must be shielded for best performance.
- For space-saving installation of multiple protectors a "honeycomb" layout is recommended (see drawings).

General Recommendations for Protection Installation

- In order to achieve the full performance of a protection circuit the application of good-practice EMC design techniques is necessary for the whole system to be protected.
- For EMP-protection usually a shield as an electromagnetic barrier to protect a certain volume is necessary. This shield avoids coupling of radiated disturbances inside the protected volume. In addition to shielding all penetrating wires must be protected from conducted transient interferences by an appropriate POE (point of entry) protection.
- Use tested, high quality POE (point of entry) protection elements for all wires entering an electromagnetic shield and install these as feed-through devices, e.g. the Meteolabor® USS-1, USS-2, USP, CSP or PLP series.

Ordering Information / Part Number

- USS-1-48V** Surge protector /filter EMP USS1-48V
1 piece required per wire
- USS-SM1** slotted nut (optional)
- USS-SK1** special box-spanner for slotted nut (optional)

Caution
Maximum torque for installation screw shall not exceed 12 Nm

Contact

Meteolabor AG
Hofstrasse 92
CH-8620 Wetzikon
Switzerland

Tel: +41 44 934 40 40
E-Mail: info@meteolabor.ch
Internet: www.meteolabor.ch

© by Meteolabor AG
All rights reserved.

Content may change without further notice 2023-07
USS-1-48V_e_V2023

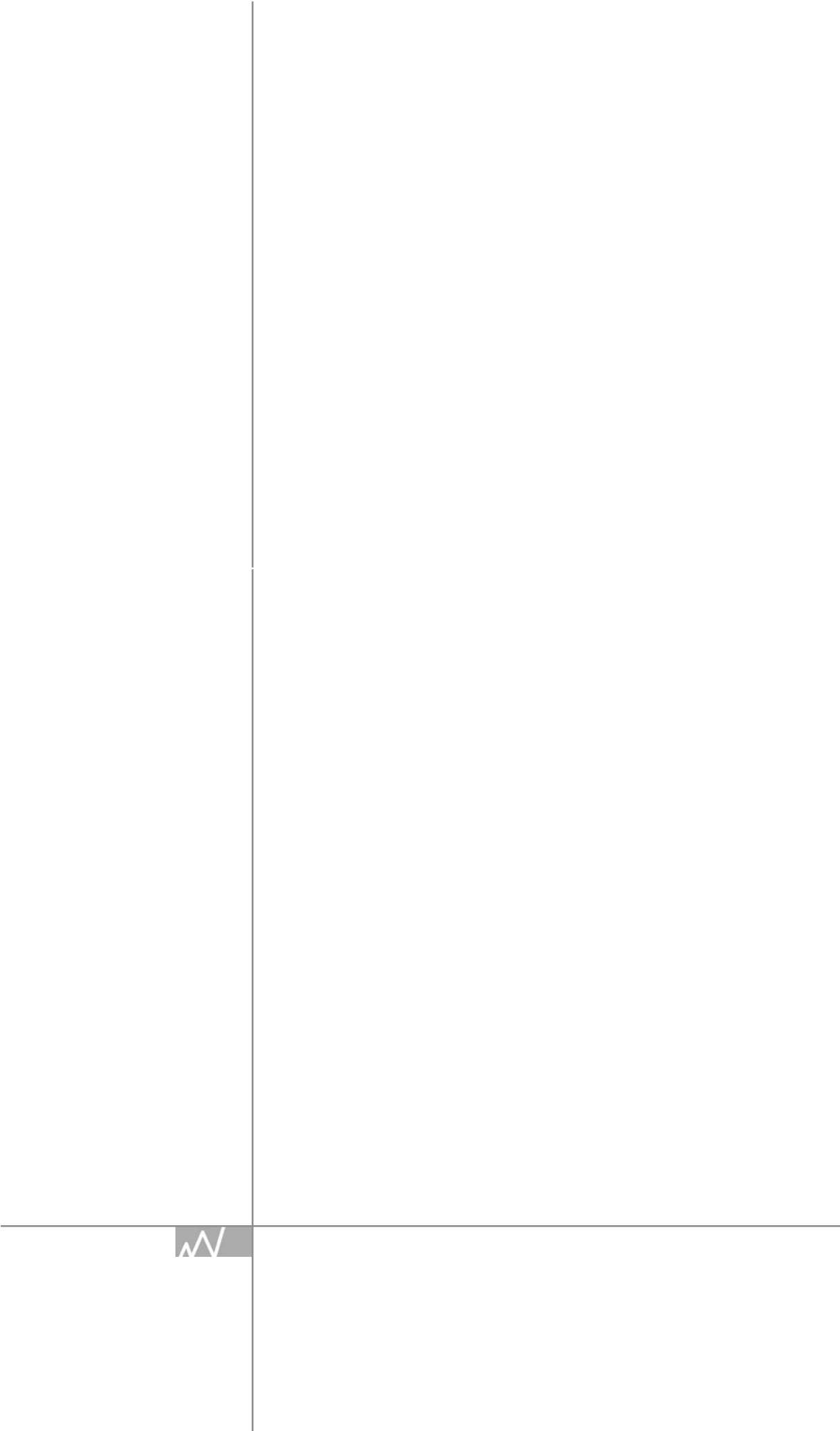

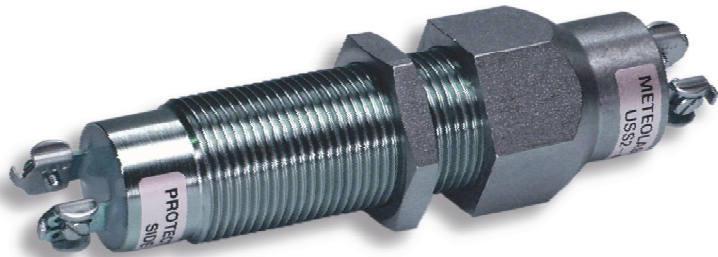

USS-2 Series

**Symmetric Signal- / Dataline
Single or Wire Pair Protection**



meteolabor



EMP Surge Protector / Filter for AC / DC Power Supplies USS-2-12V

Excellent lightning and EMP protection of an earth-free and short-circuit current limited AC or DC power supply line pair up to max. 15 V / 6 A

Protects against overvoltages produced by NEMP / HEMP, lightning or other transients

Multi-stage protection / filter design providing high transient energy absorption capability

Feed-through type steel body for direct installation to wall of Faraday cage

Threat-level tested against HEMP according to MIL-STD-188-125. For details see chapter "3 User Information"

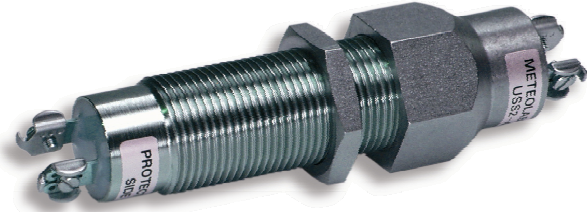

Product

The Meteolabor USS-2 series protection circuits against surge and interference voltages are designed as feed-through type mechanical units for the protection of data and control line systems. Depending on the specific application different types are available.

The highly effective multi-stage transient protection design combined with filtering components provides excellent protection against the effects of atmospheric discharges (lightning, electrostatic discharge) or a High Altitude Electro-Magnetic Pulse (HEMP), sometimes also referred to as Nuclear Electro-Magnetic Pulse (NEMP) or simply EMP. Special features of this series of protection circuits include high surge current capability, compact feed-through design and simple installation directly to Faraday cage.

Applications

The Meteolabor USS-2-12V overvoltage protector/filter is intended to protect earth-free AC or DC power supply lines, which are short-circuit current limited to < 0.5 A (or fused) against overvoltage effects caused by NEMP / HEMP or lightning strikes.

USS-2-12V uses gas tube arrestors in combination with other elements. For reliable extinction of gas tube arrestors it is very important, that the short-circuit current of the power feeding source is fused with 6A or less, or the short circuit current must be limited to less than 0.5 A

USS-2-12V has been used in many fixed installations (buildings, underground shelters etc.) as well as in portable and mobile systems like containers or shelters and vehicles, which were successfully EMP-tested according to RS105 of MIL-STD-461F.

Technical Data USS-2-12V

Application	Low voltage power	Source and load must be earth-free and short-circuit current limited
Maximum operating voltage U_{Max}	± 15 V DC / 10 V AC	
Nominal operating current I_N	6 A ($T_{amb} = 40^\circ\text{C}$)	Short-circuit must be < 0.5 A or fused 6 A or less for safe extinction of gas tube arrester
DC resistance	2 x 40 m Ω	
Max. surge current I_{Max}	2 x 10 kA	wire \rightarrow ground /case, shape 8 / 20 μs , $T_{amb} = 40^\circ\text{C}$
Max. lightning impulse current I_{imp}	2 x 2 kA	Each wire \rightarrow ground/case, shape 10 / 350 μs , at least 1 pulse
Residual voltage	< 40 V	wire \rightarrow wire, worst case, depending on pulse shape
Residual voltage	< 700 V	wire \rightarrow ground / case, worst case, depending on pulse shape
Average common mode attenuation	typ. 50 dB	at 50 Ω , from 30 MHz up to 2.4 GHz
DC earth leakage current	< 1 μA	at U_{Max} , $T_{amb} = 40^\circ\text{C}$
Operating temperature range	- 40 $^\circ\text{C}$ / + 85 $^\circ\text{C}$	
Connection terminals	6.3 x 0.8 mm	Choice of FASTON flat receptacle, solder or screw connection
Case materials		Stainless steel: Hexagon sleeve (cage) and hex nut. Free cutting steel, nickel-plated: Threaded sleeve (cage)
Max. allowed installation torque	25 Nm	Not to be exceeded under all circumstances
Dimensions (Overall)	113 x 31.2 x 27 mm	Major dimensions, details see drawing
Weight	approx. 180 g	



Dimensions

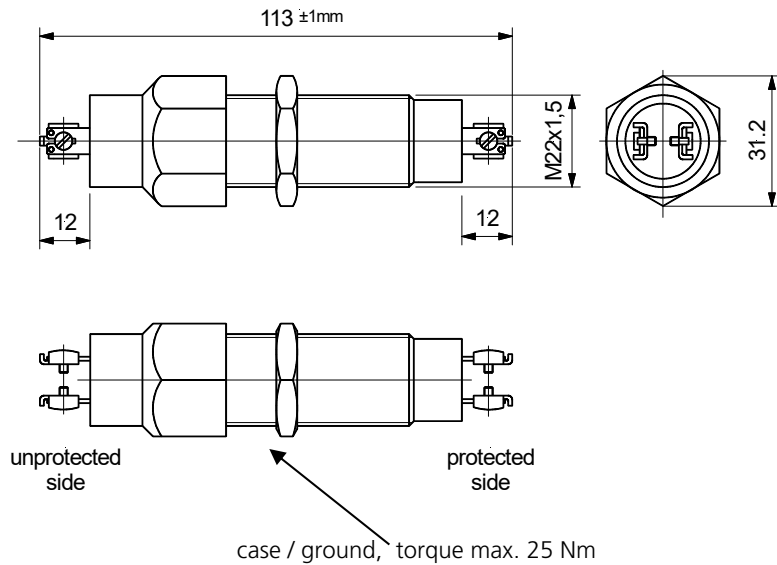

Installation Layouts

Standard drilling layout for USS-2 series with standard hexagonal nut (included, spanner size 27 mm)

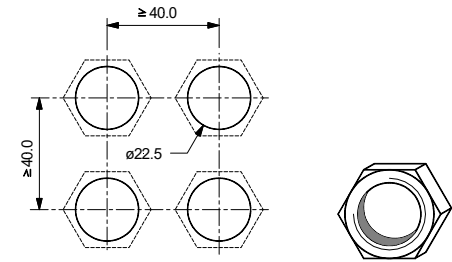

Space saving "honeycomb" mounting hole layout for USS-2 series (requires optional slotted nut USS-SM2 and USS-SK2 spanner)

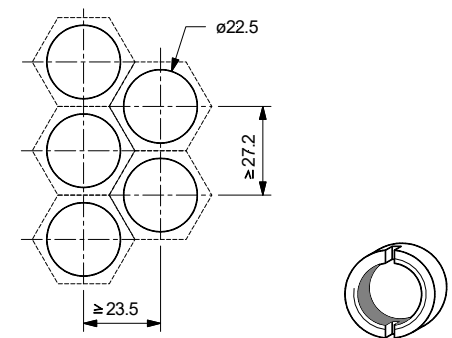

Installation Instructions

- The USS-2 series EMP protector / filters shall be installed by electrically skilled personnel.
- The electrical wiring must be done according to local regulations.
- The max. values stated in this datasheet must not be exceeded under any circumstances.
- Do not exceed max. installation torque of 25 Nm as this can destroy the device.
- USS-2 series EMP protector / filters may be directly installed into the wall of a Faraday cage as feed-through device. Otherwise the cabling on the protected side must be shielded for best performance.
- For space-saving installation of multiple protectors a "honeycomb" layout is recommended (see drawings).

General Recommendations for Protection Installation

- In order to achieve the full performance of a protection circuit the application of good-practice EMC design techniques is necessary for the whole system to be protected.
- For EMP-protection usually a shield as an electromagnetic barrier to protect a certain volume is necessary. This shield avoids coupling of radiated disturbances inside the protected volume. In addition to shielding all penetrating wires must be protected from conducted transient interferences by an appropriate POE (point of entry) protection.
- Use tested, high quality POE (point of entry) protection elements for all wires entering an electromagnetic shield and install these as feed-through devices, e.g. the Meteolabor® USS-1, USS-2, USP, CSP or PLP series.

Ordering Information / Part Number

USS-2-12V Surge protector / filter EMP USS2-12V

USS-SM2 optional slotted nut

USS-SK2 optional special socket spanner for slotted nut

 **Caution**
Maximum torque for installation screw shall not exceed 25 Nm

Contact

Meteolabor AG
Hofstrasse 92
CH-8620 Wetzikon
Switzerland

Tel: +41 44 934 40 40
E-Mail: info@meteolabor.ch
Internet: www.meteolabor.ch

© by Meteolabor AG
All rights reserved

Content may change without further notice 2023-07
USS-2-12V_e_V2023



EMP Surge Protector / Filter for AC / DC Power Supplies USS-2-24V

Excellent lightning and EMP protection of an earth-free and short-circuit current limited AC or DC power supply line pair up to max. 30 V / 6 A

Protects against overvoltages produced by NEMP / HEMP, lightning or other transients

High nominal operating current of 6 A

Multi-stage protection / filter design providing high transient energy absorption capability

Feed-through type steel body for direct installation to wall of Faraday cage

Threat-level tested against HEMP according to MIL-STD-188-125. For details see chapter "3 User Information"

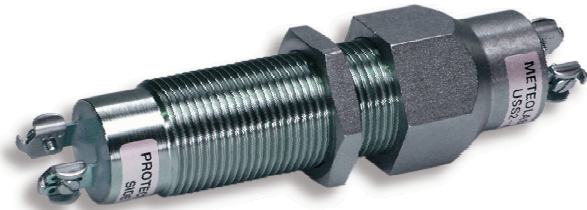

Product

The Meteolabor USS-2 series protection circuits against surge and interference voltages are designed as feed-through type mechanical units for the protection of data and control line systems. Depending on the specific application different types are available.

The highly effective multi-stage transient protection design combined with filtering components provides excellent protection against the effects of atmospheric discharges (lightning, electrostatic discharge) or a High Altitude Electro-Magnetic Pulse (HEMP), sometimes also referred to as Nuclear Electro-Magnetic Pulse (NEMP) or simply EMP. Special features of this series of protection circuits include high surge current capability, compact feed-through design and simple installation directly to Faraday cage.

Applications

The Meteolabor USS-2-24V overvoltage protector/filter is intended to protect earth-free AC or DC power supply lines, which are short-circuit current limited to < 0.5 A (or fused) against overvoltage effects caused by NEMP / HEMP or lightning strikes.

USS-2-24V uses gas tube arrestors in combination with other elements. For reliable extinction of gas tube arrestors it is very important, that the short-circuit current of the power feeding source is fused with 6A or less, or the short circuit current must be limited to less than 0.5 A.

USS-2-24V has been used in many fixed installations (buildings, underground shelters etc.) as well as in portable and mobile systems like containers or shelters and vehicles, which were successfully EMP-tested according to RS105 of MIL-STD-461F.

Technical Data USS-2-24V

Application	Low voltage power	Source and load must be earth-free and short-circuit current limited
Maximum operating voltage U_{Max}	± 30 V DC / 20 V AC	
Nominal operating current I_N	6 A	$T_{amb} = 40^\circ\text{C}$, short-circuit current must be limited to < 0.5 A or fused 6 A or less for safe extinction of gas tube arrester
DC resistance	2 x 40 m Ω	
Max. surge current I_{Max}	2 x 10 kA	wire \rightarrow ground / case, shape 8/20 μs , $T_{amb} = 40^\circ\text{C}$
Max. lightning impulse current I_{Imp}	2 x 2 kA	Each wire \rightarrow ground / case, shape 10/350 μs , at least 1 pulse
Residual voltage	< 70 V	wire \rightarrow wire, worst case, depending on pulse shape
Residual voltage	< 700 V	wire \rightarrow ground / case, worst case, depending on pulse shape
Average common mode attenuation	typ. 50 dB	at 50 Ω , up to 2.4 GHz
DC earth leakage current	< 1 μA	at U_{Max} , $T_{amb} = 40^\circ\text{C}$
Operating temperature range	- 40 $^\circ\text{C}$ / + 85 $^\circ\text{C}$	
Connection terminals	6.3 x 0.8 mm	Choice of FASTON flat receptacle, solder or screw connection
Case materials		Stainless steel: Hexagon sleeve (cage) and hex nut. Free cutting steel, nickel-plated: Threaded sleeve (cage)
Max. allowed installation torque	25 Nm	Not to be exceeded under all circumstances
Dimensions (Overall)	113 x 31.2 x 27 mm	Major dimensions, details see drawing
Weight	approx. 180 g	



Dimensions

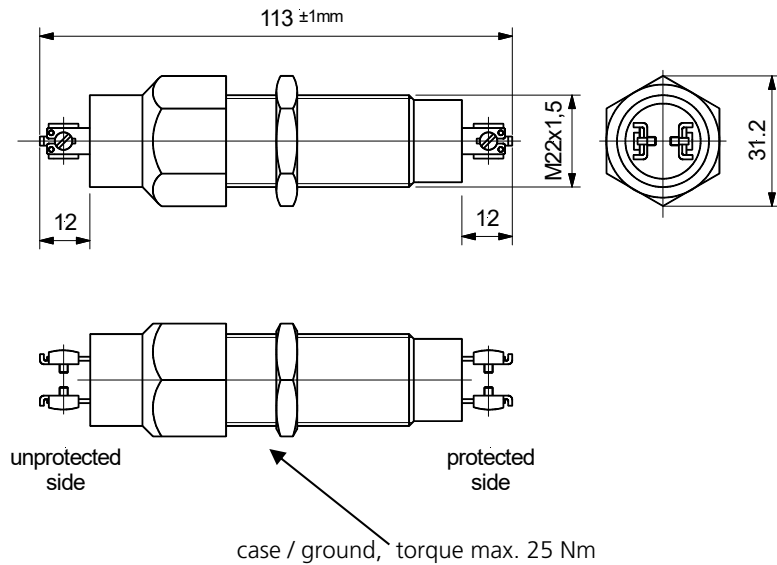

Installation Layouts

Standard drilling layout for USS-2 series with standard hexagonal nut (included, spanner size 27 mm)

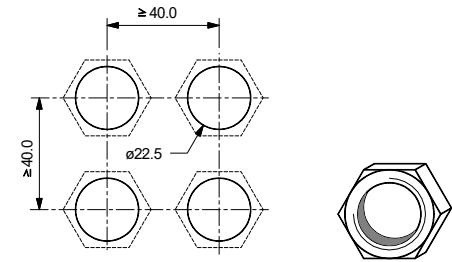

Space saving "honeycomb" mounting hole layout for USS-2 series (requires optional slotted nut USS-SM2 and USS-SK2 spanner)

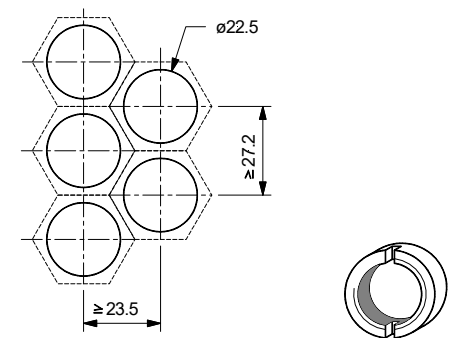

Installation Instructions

- The USS-2 series EMP protector / filters shall be installed by electrically skilled personnel.
- The electrical wiring must be done according to local regulations.
- The max. values stated in this datasheet must not be exceeded under any circumstances.
- Do not exceed max. installation torque of 25 Nm as this can destroy the device.
- USS-2 series EMP protector / filters may be directly installed into the wall of a Faraday cage as feed-through device. Otherwise the cabling on the protected side must be shielded for best performance.
- For space-saving installation of multiple protectors a "honeycomb" layout is recommended (see drawings).

General Recommendations for Protection Installation

- In order to achieve the full performance of a protection circuit the application of good-practice EMC design techniques is necessary for the whole system to be protected.
- For EMP-protection usually a shield as an electromagnetic barrier to protect a certain volume is necessary. This shield avoids coupling of radiated disturbances inside the protected volume. In addition to shielding all penetrating wires must be protected from conducted transient interferences by an appropriate POE (point of entry) protection.
- Use tested, high quality POE (point of entry) protection elements for all wires entering an electromagnetic shield and install these as feed-through devices, e.g. the Meteolabor® USS-1, USS-2, USP, CSP or PLP series.

Ordering Information / Part Number

USS-2-24V Surge protector / filter EMP USS2-24V

USS-SM2 optional slotted nut

USS-SK2 optional special socket spanner for slotted nut

 **Caution**
Maximum torque for installation screw shall not exceed 25 Nm

Contact

Meteolabor AG
Hofstrasse 92
CH-8620 Wetzikon
Switzerland

Tel: +41 44 934 40 40
E-Mail: info@meteolabor.ch
Internet: www.meteolabor.ch

© by Meteolabor AG
All rights reserved

Content may change without further notice 2023-07
USS-2-24V_e_V2023



EMP Surge Protector / Filter for AC / DC Power Supplies USS-2-48V

Excellent lightning and EMP protection of an earth-free and short-circuit current limited AC or DC power supply line pair up to max. 48 V / 6 A

Protects against overvoltages produced by NEMP / HEMP, lightning or other transients

High nominal operating current of 6 A

Multi-stage protection / filter design providing high transient energy absorption capability

Feed-through type steel body for direct installation to wall of Faraday cage

Threat-level tested against HEMP according to MIL-STD-188-125. For details see chapter "3 User Information"

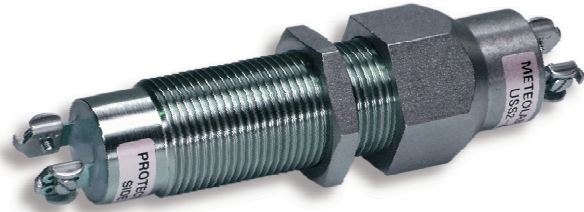

Product

The Meteolabor USS-2 series protection circuits against surge and interference voltages are designed as feed-through type mechanical units for the protection of data and control line systems. Depending on the specific application different types are available.

The highly effective multi-stage transient protection design combined with filtering components provides excellent protection against the effects of atmospheric discharges (lightning, electrostatic discharge) or a High Altitude Electro-Magnetic Pulse (HEMP), sometimes also referred to as Nuclear Electro-Magnetic Pulse (NEMP) or simply EMP. Special features of this series of protection circuits include high surge current capability, compact feed-through design and simple installation directly to Faraday cage.

Applications

The Meteolabor USS-2-48V overvoltage protector/filter is intended to protect earth-free AC or DC power supply lines, which are short-circuit current limited to < 0.5 A (or fused) against overvoltage effects caused by NEMP / HEMP or lightning strikes. For reliable extinction of gas tube arrestors it is very important, that the short-circuit current of the power feeding source is fused with 6 A or less, or the short circuit current must be limited to less than 0.5 A.

The USS-2-48V is also suitable to protect power supply lines of PoE (Power over Ethernet) circuits within 10/100 Mbit/s Ethernet applications. This is done in combination with the USS-2-AQ (NSN listed) Ethernet protector.

USS-2-48V has been used in many fixed installations (buildings, underground shelters etc.) as well as in portable and mobile systems like containers or shelters and vehicles, which were successfully EMP-tested according to RS105 of MIL-STD-461F.

Technical Data USS-2-48V

Application	Low voltage power	Source and load must be earth-free and short-circuit current limited
Maximum operating voltage U_{Max}	± 48 V DC / 32 V AC	
Nominal operating current I_N	6 A	$T_{amb} = 40^\circ\text{C}$, short-circuit current must be limited to < 0.5 A or fused 6 A or less for safe extinction of gas tube arrester
DC resistance	2 x 40 m Ω	
Max. surge current I_{Max}	2 x 10 kA	wire \rightarrow ground/case, shape 8 / 20 μs , $T_{amb} = 40^\circ\text{C}$
Max. lightning impulse current I_{imp}	2 x 2 kA	Each wire \rightarrow ground/case, shape 10 / 350 μs , at least 1 pulse
Residual voltage	< 110 V	wire \rightarrow wire, worst case, depending on pulse shape
Residual voltage	< 700 V	wire \rightarrow ground / case, worst case, depending on pulse shape
Average common mode attenuation	typ. 50 dB	at 50 Ω , up to 2.4 GHz
DC earth leakage current	< 1 μA	at U_{Max} , $T_{amb} = 40^\circ\text{C}$
Operating temperature range	- 40 $^\circ\text{C}$ / + 85 $^\circ\text{C}$	
Connection terminals	6.3 x 0.8 mm	Choice of FASTON flat receptacle, solder or screw connection
Case materials		Stainless steel: Hexagon sleeve (cage) and hex nut. Free cutting steel, nickel-plated: Threaded sleeve (cage)
Max. allowed installation torque	25 Nm	Not to be exceeded under all circumstances
Dimensions (Overall)	113 x 31.2 x 27 mm	Major dimensions, details see drawing
Weight	approx. 180 g	



Dimensions

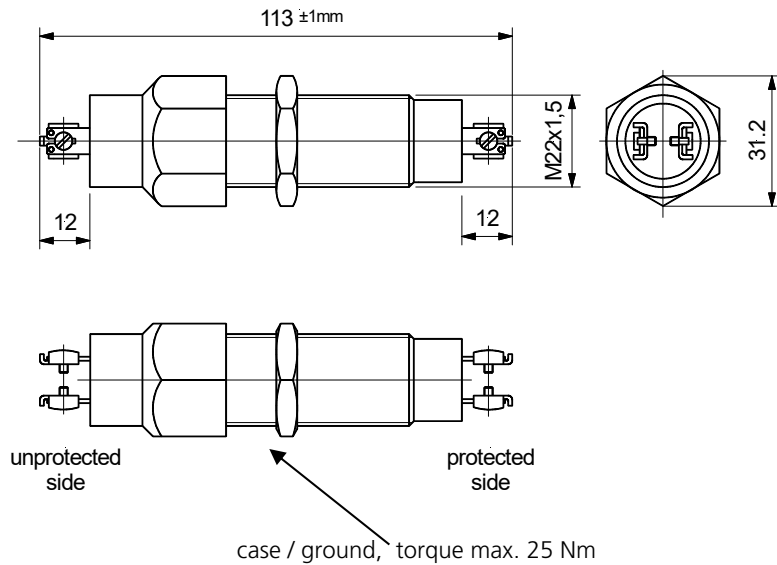

Installation Layouts

Standard drilling layout for USS-2 series with standard hexagonal nut (included, spanner size 27 mm)

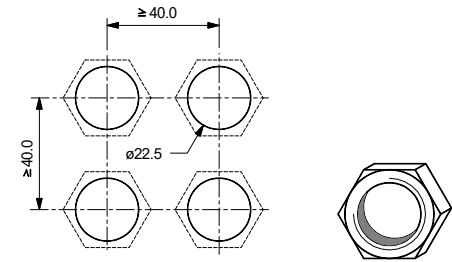

Space saving "honeycomb" mounting hole layout for USS-2 series (requires optional slotted nut USS-SM2 and USS-SK2 spanner)

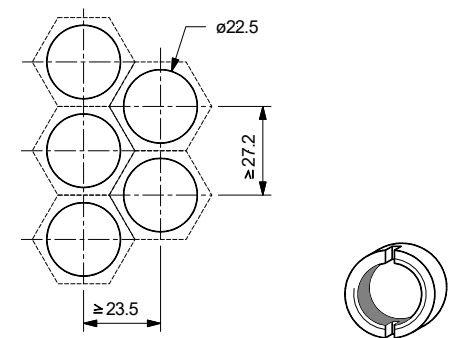

Installation Instructions

- The USS-2 series EMP protector / filters shall be installed by electrically skilled personnel.
- The electrical wiring must be done according to local regulations.
- The max. values stated in this datasheet must not be exceeded under any circumstances.
- Do not exceed max. installation torque of 25 Nm as this can destroy the device.
- USS-2 series EMP protector / filters may be directly installed into the wall of a Faraday cage as feed-through device. Otherwise the cabling on the protected side must be shielded for best performance.
- For space-saving installation of multiple protectors a "honeycomb" layout is recommended (see drawings).

General Recommendations for Protection Installation

- In order to achieve the full performance of a protection circuit the application of good-practice EMC design techniques is necessary for the whole system to be protected.
- For EMP-protection usually a shield as an electromagnetic barrier to protect a certain volume is necessary. This shield avoids coupling of radiated disturbances inside the protected volume. In addition to shielding all penetrating wires must be protected from conducted transient interferences by an appropriate POE (point of entry) protection.
- Use tested, high quality POE (point of entry) protection elements for all wires entering an electromagnetic shield and install these as feed-through devices, e.g. the Meteolabor® USS-1, USS-2, USP, CSP or PLP series.

Ordering Information / Part Number

USS-2-48V Surge protector / filter EMP USS2-48V

USS-SM2 optional slotted nut

USS-SK2 optional special socket spanner for slotted nut

Caution

 Maximum torque for installation screw shall not exceed 25 Nm

Contact

Meteolabor AG
 Hofstrasse 92
 CH-8620 Wetzikon
 Switzerland

Tel: +41 44 934 40 40
 E-Mail: info@meteolabor.ch
 Internet: www.meteolabor.ch

© by Meteolabor AG
 All rights reserved

Content may change without further notice 2023-07
 USS-2-48V_e_V2023



EMP Surge Protector / Filter for Ground-free Signals / Supplies USS-2-C

Excellent lightning and EMP protection of an earth-free and short-circuit current limited low voltage power supply or signal line pair

Protects against overvoltages produced by NEMP / HEMP, lightning or other transients

Operating up to 6 A, and up to 50 V

Multi-stage protection/filter design providing high transient energy absorption capability

Feed-through type steel body for direct installation to wall of Faraday cage

Threat-level tested against HEMP according to MIL-STD-188-125. For details see chapter "3 User Information"

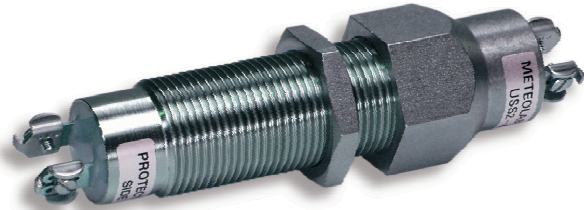

Product

The Meteolabor USS-2 series protection circuits against surge and interference voltages are designed as feed-through type mechanical units for the protection of data and control line systems. Depending on the specific application different types are available.

The highly effective multi-stage transient protection design combined with filtering components provides excellent protection against the effects of atmospheric discharges (lightning, electrostatic discharge) or a High Altitude Electro-Magnetic Pulse (HEMP), sometimes also referred to as Nuclear Electro-Magnetic Pulse (NEMP) or simply EMP. Special features of this series of protection circuits include high surge current capability, compact feed-through design and simple installation directly to Faraday cage.

Applications

The Meteolabor USS-2-C overvoltage protector / filter is intended to protect earth-free signal pairs (e.g. analog telephone) or AC or DC low voltage power supply lines, which are short-circuit current limited to < 0.5 A (or fused). USS-2-C will protect against overvoltage effects caused by NEMP / HEMP or lightning strikes.

USS-2-C uses gas tube arrestors in combination with other elements. For reliable extinction of gas tube arrestors it is very important, that the short-circuit current of the power feeding source is fused with 6 A or less, or the short circuit current must be limited to less than 0.5 A.

USS-2-C has been used in many fixed installations (buildings, underground shelters etc.) as well as in portable and mobile systems like containers, shelters and vehicles, which were successfully EMP-tested according to RS105 of MIL-STD-461F.

Technical Data USS-2-C

Application	Low voltage power	Source and load must be earth-free and short-circuit current limited
Nominal operating voltage U_{Max}	± 50 V DC / AC	Short time 150 V peak (e.g. ringing signal of telephone)
Nominal operating current I_N	6 A	$T_{amb} = 40^\circ\text{C}$, short-circuit current must be limited to < 0.5 A or fused 6 A or less for safe extinction of gas tube arrester
DC resistance	2 x 40 m Ω	
Max. surge current I_{Max}	2 x 10 kA	wires \rightarrow ground / case, shape 8/20 μs , $T_{amb} = 40^\circ\text{C}$
Max. lightning impulse current I_{Imp}	2 x 2 kA	wires \rightarrow ground / case, shape 10/350 μs , at least 1 pulse
Residual voltage	< 500 V	wire \rightarrow wire, worst case, depending on pulse shape
Residual voltage	< 700 V	wire \rightarrow ground/case, worst case, depending on pulse shape
Operating bandwidth	typ. DC – 1 MHz	Typically at 50 Ω
Insulation resistance to ground	> 1 G Ω	Wire \rightarrow ground / case measured @ 120 V DC
Operating temperature range	- 40 $^\circ\text{C}$ / + 85 $^\circ\text{C}$	
Connection terminals	6.3 x 0.8 mm	Choice of FASTON flat receptacle, solder or screw connection
Case materials		Stainless steel: Hexagon sleeve (cage) and hex nut. Free cutting steel, nickel-plated: Threaded sleeve (cage)
Max. allowed installation torque	25 Nm	Not to be exceeded under all circumstances
Dimensions (Overall)	113 x 31.2 x 27 mm	Major dimensions, details see drawing
Weight	approx. 180 g	



Dimensions

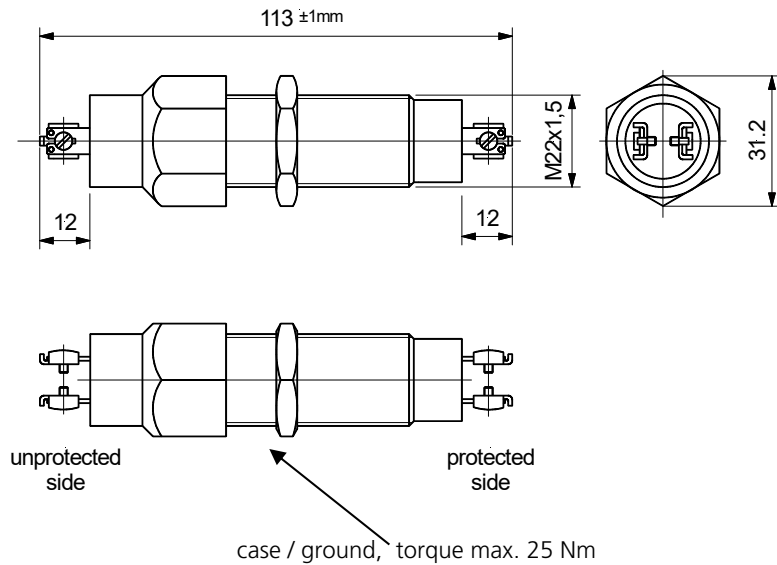

Installation Layouts

Standard drilling layout for USS-2 series with standard hexagonal nut (included, spanner size 27 mm)

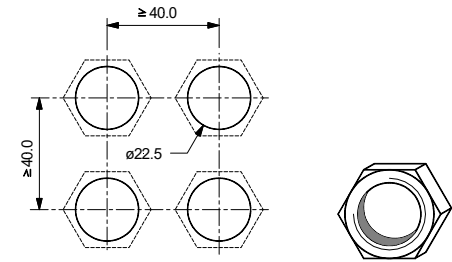

Space saving "honeycomb" mounting hole layout for USS-2 series (requires optional slotted nut USS-SM2 and USS-SK2 spanner)

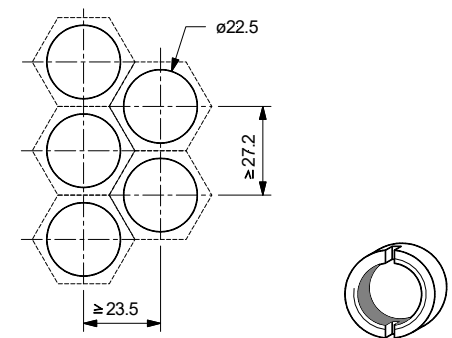

Installation Instructions

- The USS-2 series EMP protector / filters shall be installed by electrically skilled personnel.
- The electrical wiring must be done according to local regulations.
- The max. values stated in this datasheet must not be exceeded under any circumstances.
- Do not exceed max. installation torque of 25 Nm as this can destroy the device.
- USS-2 series EMP protector/filters may be directly installed into the wall of a Faraday cage as feed-through device. Otherwise the cabling on the protected side must be shielded for best performance.
- For space-saving installation of multiple protectors a "honeycomb" layout is recommended (see drawings).

General Recommendations for Protection Installation

- In order to achieve the full performance of a protection circuit the application of good-practice EMC design techniques is necessary for the whole system to be protected.
- For EMP-protection usually a shield as an electromagnetic barrier to protect a certain volume is necessary. This shield avoids coupling of radiated disturbances inside the protected volume. In addition to shielding all penetrating wires must be protected from conducted transient interferences by an appropriate POE (point of entry) protection.
- Use tested, high quality POE (point of entry) protection elements for all wires entering an electromagnetic shield and install these as feed-through devices, e.g. the Meteolabor® USS-1, USS-2, USP, CSP or PLP series.

Ordering Information / Part Number

USS-2-C Surge protector / filter EMP USS2-C

USS-SM2 optional slotted nut

USS-SK2 optional special socket spanner for slotted nut

 **Caution**
Maximum torque for installation screw shall not exceed 25 Nm

Contact

Meteolabor AG
Hofstrasse 92
CH-8620 Wetzikon
Switzerland

Tel: +41 44 934 40 40
E-Mail: info@meteolabor.ch
Internet: www.meteolabor.ch

© by Meteolabor AG
All rights reserved

Content may change without further notice 2023-07
USS-2-C_e_V2023



EMP Surge Protector / Filter for Low Voltage Power Supplies USS-2-3A-30V

Excellent lightning and EMP protection for a single wire of a low voltage power supply up to 30 V / 3A

Protects against overvoltages produced by NEMP / HEMP, lightning or other transients

Coordinated multi-stage protection/filter design providing high transient surge current capability

Feed-through type steel body for direct installation to wall of Faraday cage

Threat-level tested against HEMP according to MIL-STD-188-125. For details see chapter "3 User Information"

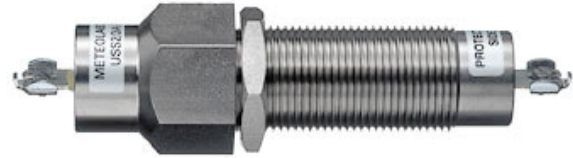

Product

The Meteolabor USS-2 series protection circuits against surge and interference voltages are designed as feed-through type mechanical units for the protection of data and control line systems. Depending on the specific application different types are available.

The highly effective multi-stage transient protection design combined with filtering components provides excellent protection against the effects of atmospheric discharges (lightning, electrostatic discharge) or a High Altitude Electro-Magnetic Pulse (HEMP), sometimes also referred to as Nuclear Electro-Magnetic Pulse (NEMP) or simply EMP. Special features of this series of protection circuits include high surge current capability, compact feed-through design and simple installation directly to Faraday cage.

Applications

Meteolabor USS-2-3A-30V provides excellent protection for a single wire of a power supply with a peak voltage of 30 V DC or 20V AC and a current up to 3 A. It will reliably protect connected sensitive electronic equipment such as telecommunication equipment, computers, etc. against the effects of lightning and EMP.

Best protection and filtering effect is achieved in a feed-through installation from an unprotected volume into a shielded and protected room.

This guarantees optimized protection of mission critical equipment against very fast transient overvoltages (e.g. NEMP / HEMP).

USS-2-3A-30V has been used in many fixed installations (buildings, underground shelters etc.) as well as in portable and mobile systems like containers or shelters and vehicles, which were successfully EMP-tested according to RS105 of MIL-STD-461F.

Technical Data USS-2-3A-30V

Application	Low voltage power	Protects 1 wire, AC or DC of grounded power supply
Max. operating voltage	±30 V DC or 20 V AC	voltage wire to ground / case
Max. operating current	3 A	@ T _{amb} = 45°C, short-circuit current must be limited to 3 A
Max. surge current I _{Max}	20 kA	Wire → ground / case, shape 8 / 20 μs, at least 1 pulse
Max. lightning impulse current I _{Imp}	2 kA	Wire → ground / case, shape 10 / 350 μs, at least 1 pulse
DC resistance input - output	< 200 mΩ	typically
Max. leakage current	< 10 μA	Measured @ 30 V DC
Residual voltage	< 70 V	Wires → ground / case, pulse 4 kV / 2 kA according to IEC 61000-4-5
Low pass cut-off frequency	1 MHz	Typically, measured in 50 Ohms system
Average attenuation	50 dB	Typically, measured in 50 Ohms system 10 MHz to 2.4 GHz
Connection terminals	6.3 x 0.8 mm	Choice of FASTON flat receptacle, solder or screw connection
Case material		Stainless steel: Hexagon sleeve (cage) and hex nut. Free cutting steel, nickel-plated: Threaded sleeve (cage)
Max. allowed installation torque	25 Nm	Not to be exceeded under all circumstances
Dimensions	27x32x113 mm	Major dimensions, details see drawing
Weight	approx. 180 g	

Dimensions [mm]

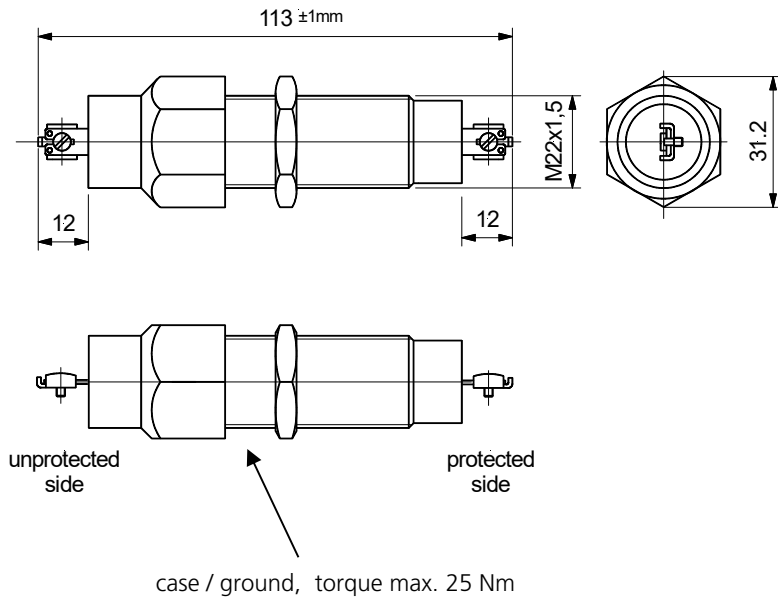

Installation Layouts

Standard drilling layout for USS-2 series with standard hexagonal nut (included, spanner size 27 mm)

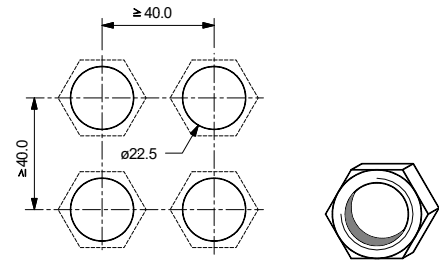

Space saving "honeycomb" mounting hole layout for USS-2 series (requires optional slotted nut USS-SM2 and USS-SK2 spanner)

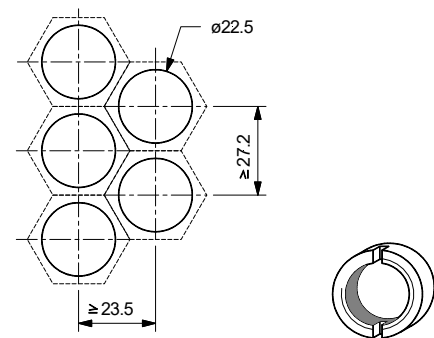

Installation Notes

- The USS-2 series EMP protector / filters shall be installed by electrically skilled personnel.
- The electrical wiring must be done according to local regulations.
- The max. values stated in this datasheet must not be exceeded under any circumstances.
- Do not exceed max. installation torque of 25 Nm as this can destroy the device.
- USS-2 series EMP protector / filters may be directly installed into the wall of a Faraday cage as feed-through device. Otherwise the cabling on the protected side must be shielded for best performance.
- For space-saving installation of multiple protectors a "honeycomb" layout is recommended (see drawings).

Ordering Information / Part Number

USS-2-3A-30V Surge Protector / Filter EMP USS2-3A-30V

USS-SM2 optional slotted nut

USS-SK2 optional special socket spanner for slotted nut

General Recommendations for Protection Installation

- In order to achieve the full performance of a protection circuit the application of good-practice EMC design techniques is necessary for the whole system to be protected.
- For EMP-protection usually a shield as an electromagnetic barrier to protect a certain volume is necessary. This shield avoids coupling of radiated disturbances inside the protected volume. In addition to shielding all penetrating wires must be protected from conducted transient interferences by an appropriate POE (point of entry) protection.
- Use tested, high quality POE (point of entry) protection elements for all wires entering an electromagnetic shield and install these as feed-through devices, e.g. the Meteolabor® USS-1, USS-2, USP, CSP or PLP series.



Caution

Maximum torque for installation screw shall not exceed 25 Nm

Contact

Meteolabor AG
Hofstrasse 92
CH-8620 Wetzikon
Switzerland

Tel: +41 44 934 40 40
E-Mail: info@meteolabor.ch
Internet: www.meteolabor.ch

© by Meteolabor AG
All rights reserved

Content may change without further notice 2023-07
USS-2-3A-30V_e_V2023

EMP Surge Protector / Filter for AC / DC Power Supplies USS-2-250V-6A

Excellent lightning and EMP protection of a single wire and short-circuit current limited AC or DC power supply line pair up to max. 350 VDC / 6A.

Protects against overvoltages produced by NEMP / HEMP, lightning or other transients

Multi-stage protection / filter design providing high transient energy absorption capability

Feed-through type steel body for direct installation to wall of Faraday cage

Threat-level tested against HEMP according to MIL-STD-188-125. For details see chapter "3 User Information"

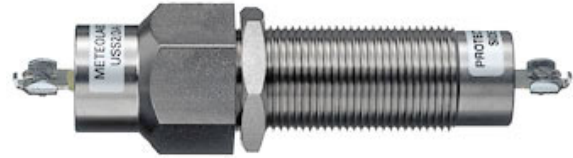

Product

The Meteolabor USS-2 series protect circuits against surge and interference voltages are designed as feed-through type mechanical units for the protection of data and control line systems..

The highly effective multi-stage transient protection design combined with filtering components provides excellent protection against the effects of atmospheric discharges (lightning, electrostatic discharge) or a High Altitude Electro-Magnetic Pulse (HEMP), sometimes also referred to as Nuclear Electro-Magnetic Pulse (NEMP) or simply EMP. Special features of this series of protection circuits include high surge current capability, compact feed-through design and simple installation directly to Faraday cage.

Applications

The Meteolabor USS-2-250V-6A overvoltage protector/filter is intended to protect a single wire supply or signal line against overvoltage effects caused by NEMP / HEMP or lightning strikes.

USS-2-250V-6A can be used in fixed installations (buildings, underground shelters etc.) as well as in portable and mobile systems like containers or shelters and vehicles.

Technical Data USS-2-250V-6A

Application	Power, Signal line	Protects a single wire power or signal line against ground.
Maximum operating voltage U_{Max}	± 350 VDC / 250 V AC	Max. voltage against ground
Nominal operating current I_N	6 A	$T_{amb} = 45^\circ\text{C}$
DC resistance	< 50 m Ω	typical
Max. surge current I_{Max}	10 kA	wire \rightarrow ground/case, shape 8 / 20 μs , at least once
Max. lightning impulse current I_{imp}	1 kA	wire \rightarrow ground/case, shape 10 / 350 μs , at least 1 pulse
Residual voltage	< 1.5 kV	wire \rightarrow ground / case, shape 4 kV / 2 kA acc. to IEC 61000-4-5
Bandwidth	435 kHz	Typical for 50 Ω
Average common mode attenuation	typ. 50 dB	at 50 Ω , up to 2.4 GHz
Earth leakage current	< 1.4 mA	measured with 250 VAC
Operating temperature range	$-40^\circ\text{C} / +85^\circ\text{C}$	
Connection terminals	6.3 mm x 0.8 mm	Choice of FASTON flat receptacle, solder or screw connection
Case materials		Stainless steel: Hexagon sleeve (cage) and hex nut. Free cutting steel, nickel-plated: Threaded sleeve (cage)
Max. allowed installation torque	25 Nm	Not to be exceeded under all circumstances
Dimensions (Overall)	113 x 31.2 x 27 mm	Major dimensions, details see drawing
Weight	approx. 180 g	



Dimensions

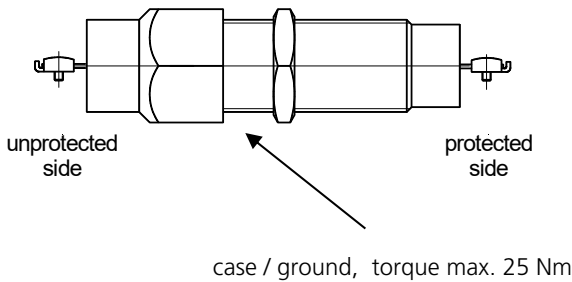
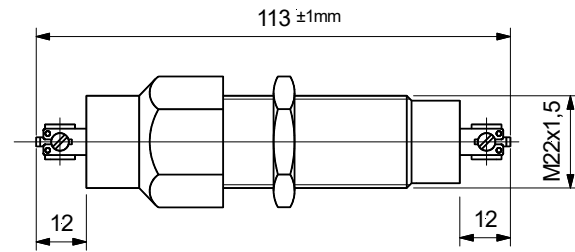

Installation Layouts

Standard drilling layout for USS-2 series with standard hexagonal nut (included, spanner size 27 mm)

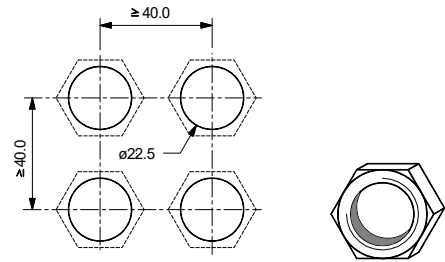

Space saving "honeycomb" mounting hole layout for USS-2 series (requires optional slotted nut USS-SM2 and USS-SK2 spanner)

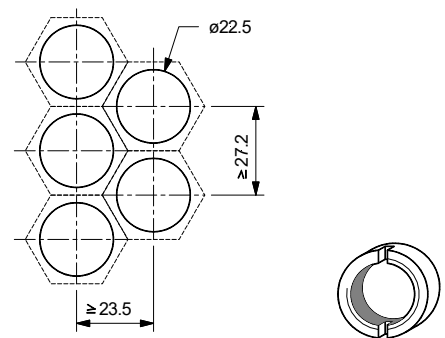

Installation Instructions

- The USS-2 series EMP protector / filters shall be installed by electrically skilled personnel.
- The electrical wiring must be done according to local regulations.
- The max. values stated in this datasheet must not be exceeded under any circumstances.
- Do not exceed max. installation torque of 25 Nm as this can destroy the device.
- USS-2 series EMP protector / filters may be directly installed into the wall of a Faraday cage as feed-through device. Otherwise the cabling on the protected side must be shielded for best performance.
- For space-saving installation of multiple protectors a "honeycomb" layout is recommended (see drawings).

General Recommendations for Protection Installation

- In order to achieve the full performance of a protection circuit the application of good-practice EMC design techniques is necessary for the whole system to be protected.
- For EMP-protection usually a shield as an electromagnetic barrier to protect a certain volume is necessary. This shield avoids coupling of radiated disturbances inside the protected volume. In addition to shielding all penetrating wires must be protected from conducted transient interferences by an appropriate POE (point of entry) protection.
- Use tested, high quality POE (point of entry) protection elements for all wires entering an electromagnetic shield and install these as feed-through devices, e.g. the Meteolabor® USS-1, USS-2, USP, CSP or PLP series.

Ordering Information / Part Number

USS-2-250V-6A Surge protector / filter EMP

USS-SM2 optional slotted nut

USS-SK2 optional special socket spanner for slotted nut



Caution

Maximum torque for installation screw shall not exceed 25 Nm

Contact

Meteolabor AG
Hofstrasse 92
CH-8620 Wetzikon
Switzerland

Tel: +41 44 934 40 40
E-Mail: info@meteolabor.ch
Internet: www.meteolabor.ch

© by Meteolabor AG
All rights reserved

Content may change without further notice 2023-07
USS-2-250V-6A_V2023



EMP Surge Protector / Filter for 1 pair 2 Mbit/s data / telephone USS-2-2048-F

Excellent lightning and EMP protection for a wire pair of an analog or digital telephone or dataline up to 2 Mbit/s

Protects against overvoltages produced by NEMP / HEMP, lightning or other transients

Coordinated multi-stage protection/filter design providing high surge current capability

Feed-through type steel body for direct installation to wall of Faraday cage

Threat-level tested against HEMP according to MIL-STD-188-125. For details see chapter "3 User Information"

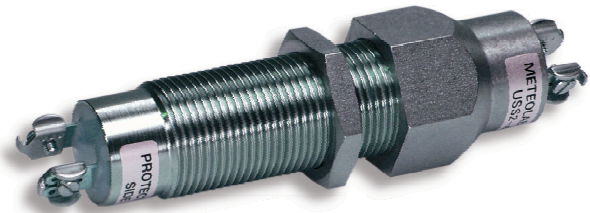

Product

The Meteolabor USS-2 series protection circuits against surge and interference voltages are designed as feed-through type mechanical units for the protection of data and control line systems. Depending on the specific application different types are available.

The highly effective multi-stage transient protection design combined with filtering components provides excellent protection against the effects of atmospheric discharges (lightning, electrostatic discharge) or a High Altitude Electro-Magnetic Pulse (HEMP), sometimes also referred to as Nuclear Electro-Magnetic Pulse (NEMP) or simply EMP. Special features of this series of protection circuits include high surge current capability, compact feed-through design and simple installation directly to Faraday cage.

Applications

Meteolabor USS-2-2048-F provides excellent protection for a pair of an analog or digital telephone line with data rates up to 2 Mbit/s. It will reliably protect connected sensitive electronic equipment such as modems and other telecommunication equipment, computers, etc. against the effects of lightning and EMP.

Best protection and filtering effect is achieved in a feed-through installation from an unprotected volume into a shielded and protected room.

This guarantees optimized protection of mission critical equipment against very fast transient overvoltages (e.g. NEMP / HEMP).

USS-2-2048-F has been used in many fixed installations (buildings, underground shelters etc.) as well as in portable and mobile systems like containers or shelters and vehicles, which were successfully EMP-tested according to RS105 of MIL-STD-461F.

Technical Data USS-2-2048-F

Application	Analog or digital telephone line	Protects 1 pair, permits data rate up to 2 Mbit/s
Max. operating voltage	±150 V	Peak voltage between wire pair
Max. operating current	0.5 A	@ T _{amb} = 45°C
Data rate	2 Mbit/s	POTS, ISDN, ADSL or HDSL
Max. surge current I _{Max}	2 x 10 kA	Each wire → ground / case, shape 8/20 μs, at least 1 pulse
Max. lightning impulse current I _{imp}	2 x 2 kA	Each wire → ground / case, shape 10/350 μs, at least 1 pulse
DC resistance input - output	< 0.5 Ω	Each path
Max. leakage current	< 0.5 μA	Measured @ 120 V DC
Residual voltage common mode	< 380 V	Wires → ground / case, pulse 4 kV / 2 kA according to IEC 61000-4-5
Residual voltage differential mode	< 380 V	Wire → wire, pulse 4 kV / 2 kA according to IEC 61000-4-5
Connection terminals	6.3 x 0.8 mm	Choice of FASTON flat receptacle, solder or screw connection
Case material		Stainless steel: Hexagon sleeve (cage) and hex nut. Free cutting steel, nickel-plated: Threaded sleeve (cage)
Max. allowed installation torque	25 Nm	Not to be exceeded under all circumstances
Dimensions	27 x 32 x 113 mm	Major dimensions, details see drawing
Weight	approx. 180 g	



Dimensions [mm]

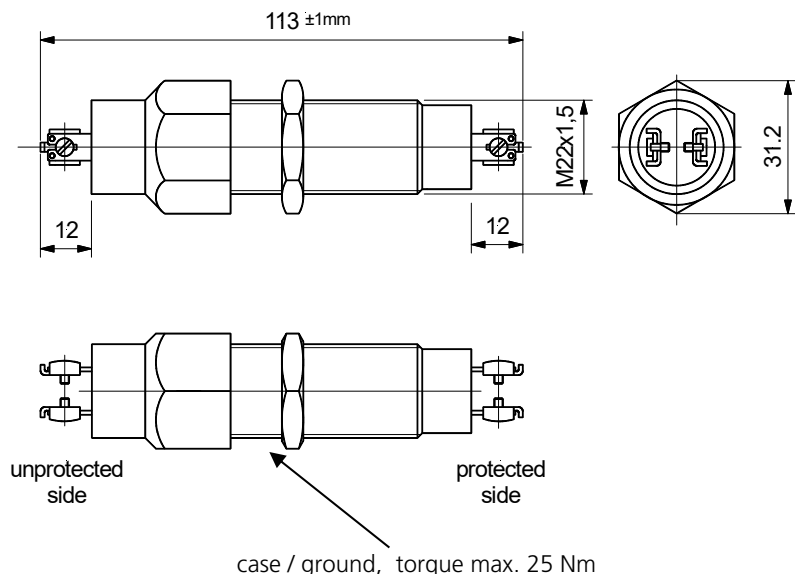

Installation Layouts

Standard drilling layout for USS-2 series with standard hexagonal nut (included, spanner size 27 mm)

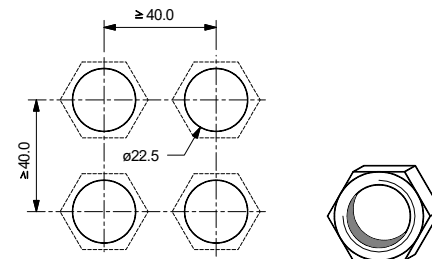

Space saving "honeycomb" mounting hole layout for USS-2 series (requires optional slotted nut USS-SM2 and USS-SK2 spanner)

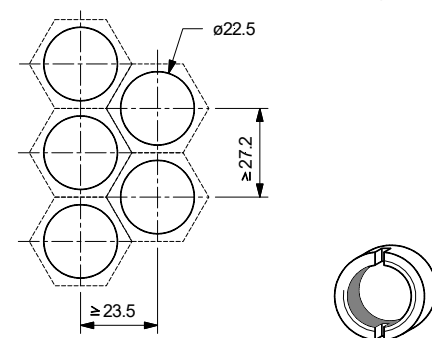

Installation Notes

- The USS-2 series EMP protector / filters shall be installed by electrically skilled personnel.
- The electrical wiring must be done according to local regulations.
- The max. values stated in this datasheet must not be exceeded under any circumstances.
- Do not exceed max. installation torque of 25 Nm as this can destroy the device.
- USS-2 series EMP protector / filters may be directly installed into the wall of a Faraday cage as feed-through device. Otherwise the cabling on the protected side must be shielded for best performance.
- For space-saving installation of multiple protectors a "honeycomb" layout is recommended (see drawings).

General Recommendations for Protection Installation

- In order to achieve the full performance of a protection circuit the application of good-practice EMC design techniques is necessary for the whole system to be protected.
- For EMP-protection usually a shield as an electromagnetic barrier to protect a certain volume is necessary. This shield avoids coupling of radiated disturbances inside the protected volume. In addition to shielding all penetrating wires must be protected from conducted transient interferences by an appropriate POE (point of entry) protection.
- Use tested, high quality POE (point of entry) protection elements for all wires entering an electromagnetic shield and install these as feed-through devices, e.g. the Meteolabor® USS-1, USS-2, USP, CSP or PLP series.

Ordering Information / Part Number

USS-2-2048-F Surge Protector / Filter EMP USS2-2048-F

USS-SM2 optional slotted nut

USS-SK2 optional special socket spanner for slotted nut

Caution
 Maximum torque for installation screw shall not exceed 25 Nm

Contact

Meteolabor AG
 Hofstrasse 92
 CH-8620 Wetzikon
 Switzerland

Tel: +41 44 934 40 40
 E-Mail: info@meteolabor.ch
 Internet: www.meteolabor.ch

© by Meteolabor AG
 All rights reserved

Content may change without further notice 2023-07
 USS-2-2048-F_V2023



EMP Surge Protector / Filter for 1 pair 10 / 100 Mbit/s Ethernet USS-2-AQ

Excellent lightning and EMP protection for a single twisted pair of a 10 / 100 Mbit/s Ethernet link

Protects against overvoltages produced by NEMP / HEMP, lightning or other transients

Multi-stage protection / filter design providing high transient energy absorption capability

Input and output are isolated by a magnetic circuit

Feed-through type steel body for direct installation to wall of Faraday cage

Threat-level tested against HEMP according to MIL-STD-188-125. For details see chapter "3 User Information"

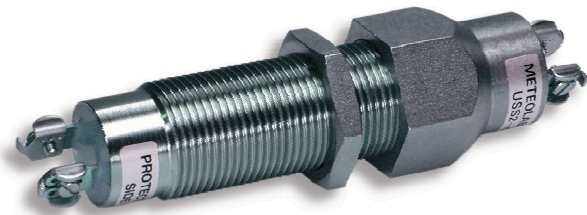

Product

The Meteolabor USS-2 series protection circuits against surge and interference voltages are designed as feed-through type mechanical units for the protection of data and control line systems. Depending on the specific application different types are available.

The highly effective multi-stage transient protection design combined with filtering components provides excellent protection against the effects of atmospheric discharges (lightning, electrostatic discharge) or a High Altitude Electro-Magnetic Pulse (HEMP), sometimes also referred to as Nuclear Electro-Magnetic Pulse (NEMP) or simply EMP. Special features of this series of protection circuits include high surge current capability, compact feed-through design and simple installation directly to Faraday cage.

Applications

Meteolabor USS-2-AQ provides excellent protection for one twisted pair of a 10 / 100 Mbit/s Ethernet connection of sensitive electronics such as computers, telecommunication equipment etc. against the effects of lightning and EMP. Input and output are isolated by a magnetic circuit which provides best protection and filtering effect in a feed-through installation from an unprotected volume into a shielded and protected room.

For a 10 / 100 Mbit/s Ethernet link two pieces USS-2-AQ are required (1 piece per Rx or Tx twisted pair respectively). This guarantees optimized protection of mission critical equipment against very fast transient overvoltages (e.g. NEMP / HEMP).

The protectors / filters have been used in many fixed installations (buildings, underground shelters etc.) as well as in portable and mobile systems like containers or shelters and vehicles, which were successfully EMP-tested according to RS105 of MIL-STD-461F.

Technical Data USS-2-AQ

Application	Ethernet protection	1 pair 10 / 100 Mbit/s, not applicable for Power over Ethernet (PoE)
Max. operating voltage	±3V	Peak voltage between wire pair
Data rate	10 / 100 Mbit/s	Ethernet or Fast Ethernet as per IEEE 802.3
Max. surge current I_{Max}	2 x 10 kA	Each wire → ground/case, shape 8 / 20 μs, at least 1 pulse
Max. lightning impulse current I_{Imp}	2 x 2 kA	Each wire → ground/case, shape 10 / 350 μs, at least 1 pulse
DC resistance input - output	Open circuit	Input / output isolated
Isolation resistance to ground	> 1 GΩ	Measured @ 100 V DC
Residual voltage common mode	< 20 V	Wires → ground / case, pulse 4 kV / 2 kA according to IEC 61000-4-5
Residual voltage differential mode	< 20 V	Wire → wire, pulse 4 kV / 2 kA according to IEC 61000-4-5
Connection terminals	6.3 x 0.8 mm	Choice of FASTON flat receptacle, solder or screw connection
Case material		Stainless steel: Hexagon sleeve (cage) and hex nut. Free cutting steel, nickel-plated: Threaded sleeve (cage)
Max. allowed installation torque	25 Nm	Not to be exceeded under all circumstances
Dimensions	27 x 32 x 113 mm	Major dimensions, details see drawing
Weight	approx. 180 g	



Dimensions [mm]

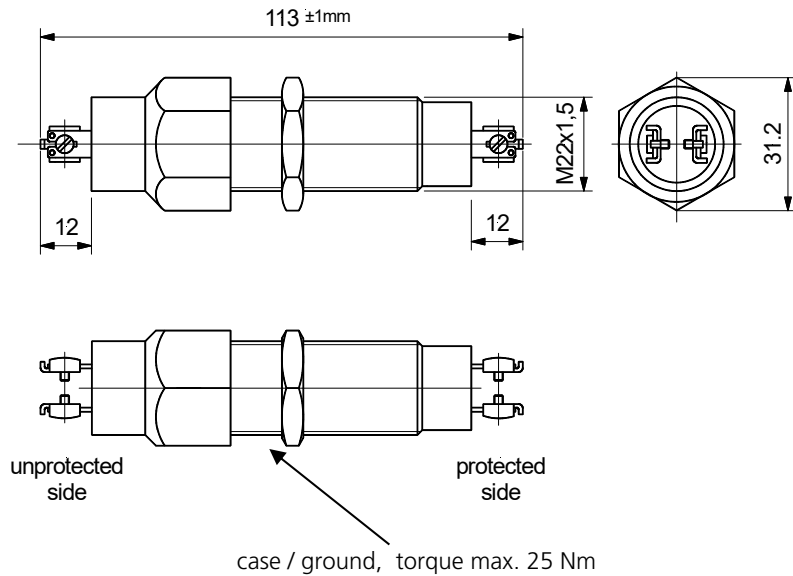

Installation Layouts

Standard drilling layout for USS-2 series with standard hexagonal nut (included, spanner size 27 mm)

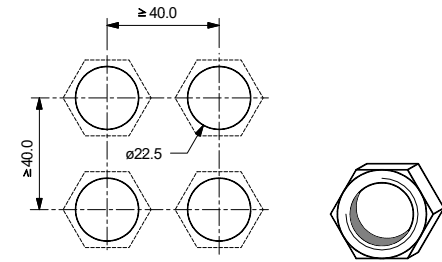

Space saving "honeycomb" mounting hole layout for USS-2 series (requires optional slotted nut USS-SM2 and USS-SK2 spanner)

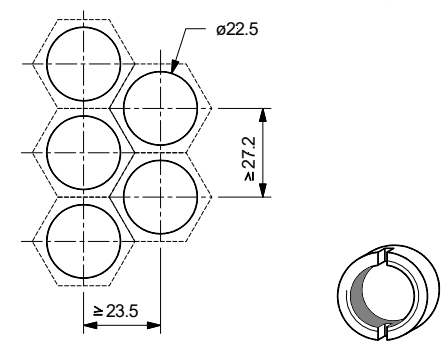

Installation Notes

- The USS-2 series EMP protector / filters shall be installed by electrically skilled personnel.
- The electrical wiring must be done according to local regulations.
- The max. values stated in this datasheet must not be exceeded under any circumstances.
- Do not exceed max. installation torque of 25 Nm as this can destroy the device.
- USS-2 series EMP protector/filters may be directly installed into the wall of a Faraday cage as feed-through device. Otherwise the cabling on the protected side must be shielded for best performance.
- For space-saving installation of multiple protectors a "honeycomb" layout is recommended (see drawings).

General Recommendations for Protection Installation

- In order to achieve the full performance of a protection circuit the application of good-practice EMC design techniques is necessary for the whole system to be protected.
- For EMP-protection usually a shield as an electromagnetic barrier to protect a certain volume is necessary. This shield avoids coupling of radiated disturbances inside the protected volume. In addition to shielding all penetrating wires must be protected from conducted transient interferences by an appropriate POE (point of entry) protection.
- Use tested, high quality POE (point of entry) protection elements for all wires entering an electromagnetic shield and install these as feed-through devices, e.g. the Meteolabor® USS-1, USS-2, USP, CSP or PLP series.

Ordering Information / Part Number

USS-2-AQ Surge Protector / Filter EMP USS2-AQ
 Note: For 10 / 100Mbit/s Ethernet link 2 pieces USS-2-AQ are required (1 piece per Rx or Tx twisted pair respectively)
 NSN-Nr. 5920-12-354-9312

USS-SM2 optional slotted nut
USS-SK2 optional special socket spanner for slotted nut

Caution
 Maximum torque for installation screw shall not exceed 25 Nm

Contact

Meteolabor AG
 Hofstrasse 92
 CH-8620 Wetzikon
 Switzerland

Tel: +41 44 934 40 40
 E-Mail: info@meteolabor.ch
 Internet: www.meteolabor.ch

© by Meteolabor AG
 All rights reserved

Content may change without further notice 2023-07
 USS-2-AQ_e_V2027

EMP Surge Protector / Filter for Analog 30 MHz Video Signal USS-2-TV75-BNC

Excellent lightning and EMP protection for an analog video signal with up to 30 MHz bandwidth

Coaxial BNC sockets, isolated from ground / case

Protects against overvoltages produced by NEMP / HEMP, lightning or other transients

Coordinated multi-stage protection / filter design providing high surge current capability

Feed-through type steel body for direct installation to wall of Faraday cage

Threat-level tested against HEMP according to MIL-STD-188-125. For details see chapter "3 User Information"



Product

The Meteolabor USS-2 series protection circuits against surge and interference voltages are designed as feed-through type mechanical units for the protection of data and control line systems. Depending on the specific application different types are available.

The highly effective multi-stage transient protection design combined with filtering components provides excellent protection against the effects of atmospheric discharges (lightning, electrostatic discharge) or a High Altitude Electro-Magnetic Pulse (HEMP), sometimes also referred to as Nuclear Electro-Magnetic Pulse (NEMP) or simply EMP. Special features of this series of protection circuits include high surge current capability, compact feed-through design and simple installation directly to Faraday cage.

Applications

Meteolabor USS-2-TV75-BNC provides excellent protection for an analog floating or grounded coaxial cable with professional video signal, having a bandwidth up to 30 MHz. It does not ground the shield to avoid ground loops. It will reliably protect connected electronic equipment such as video equipment, against the effects of lightning and EMP. Best protection and filtering effect is achieved in a feed-through installation from an unprotected volume into a shielded and protected room.

This guarantees optimized protection of mission critical equipment against very fast transient overvoltages (e.g. NEMP / HEMP).

USS-2-TV75-BNC has been used in many fixed installations (buildings, underground shelters etc.) as well as in portable and mobile systems like containers or shelters and vehicles, which were successfully EMP-tested according to RS105 of MIL-STD-461F.

Technical Data USS-2-TV75-BNC

Application	Analog video signal	Up to 30 MHz video bandwidth, shield floating to avoid ground loops
Max. operating voltage	± 2.5 V	Peak voltage between inner and outer connector of coaxial cable
Max. operating current	0.2 A	@ T _{amb} = 45°C
Bandwidth	DC – 30 MHz	-3 dB bandwidth, 75 Ohms
Insertion loss	0.8 dB	Typically DC – 10 MHz
Max. surge current I _{Max}	2 x 10 kA	Each inner / outer conductor → ground/case, shape 8/20 μs, 1 pulse
Max. lightning impulse current I _{Imp}	2 x 2 kA	Each conductor → ground / case, shape 10/350 μs, at least 1 pulse
DC resistance input - output	< 2.9 Ω	Totally both inner and outer conductor, typical value
Max. leakage current	< 0.5 μA	Measured @ max. operating voltage
Residual voltage common mode	< 450 V	Outer wire (shield) → ground / case, value depending on pulse shape
Residual voltage differential mode	< 14 V	Inner wire → outer conductor, value depending on pulse shape
Connection terminals	BNC sockets	Unprotected and protected side, shield floating
Case material		Stainless steel: Hexagon sleeve (cage) and hex nut. Free cutting steel, nickel-plated: Threaded sleeve (cage)
Max. allowed installation torque	25 Nm	Not to be exceeded under all circumstances
Dimensions	27 x 32 x 113 mm	Major dimensions, details see drawing
Weight	approx. 180 g	



Dimensions [mm]

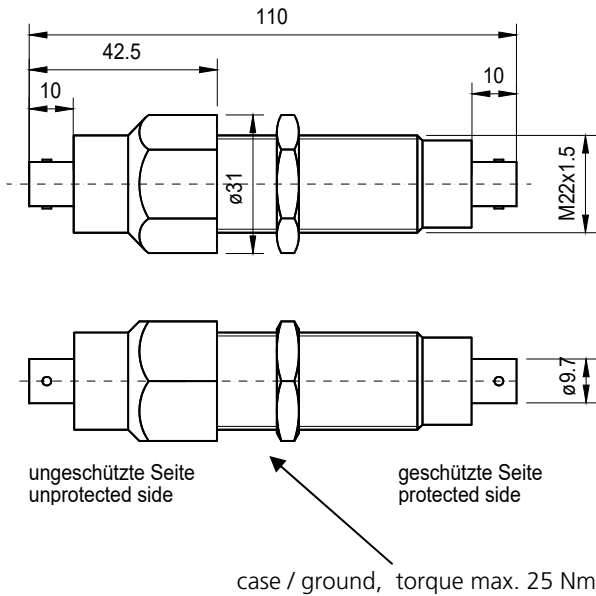

Installation Layouts

Standard drilling layout for USS-2 series with standard hexagonal nut (included, spanner size 27 mm)

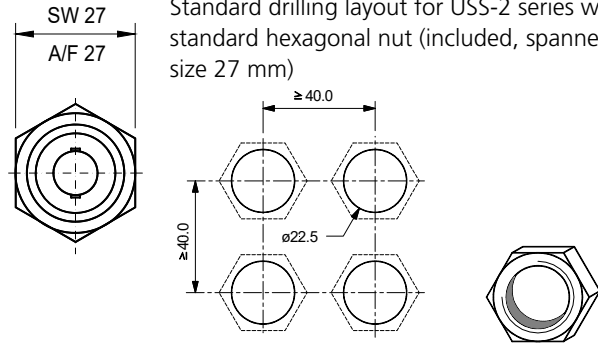

Space saving "honeycomb" mounting hole layout for USS-2 series (requires optional slotted nut USS-SM2 and USS-SK2 spanner)

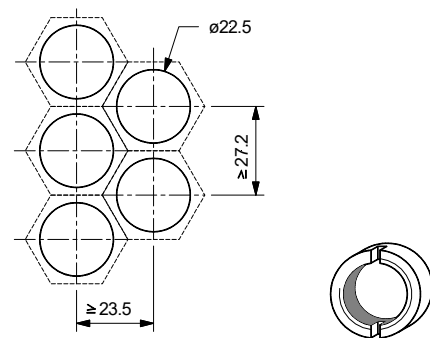

Installation Notes

- The USS-2 series EMP protector / filters shall be installed by electrically skilled personnel.
- The electrical wiring must be done according to local regulations.
- The max. values stated in this datasheet must not be exceeded under any circumstances.
- Do not exceed max. installation torque of 25 Nm as this can destroy the device.
- USS-2 series EMP protector / filters may be directly installed into the wall of a Faraday cage as feed-through device. Otherwise the cabling on the protected side must be shielded for best performance.
- For space-saving installation of multiple protectors a "honeycomb" layout is recommended (see drawings).

General Recommendations for Protection Installation

- In order to achieve the full performance of a protection circuit the application of good-practice EMC design techniques is necessary for the whole system to be protected.
- For EMP-protection usually a shield as an electromagnetic barrier to protect a certain volume is necessary. This shield avoids coupling of radiated disturbances inside the protected volume. In addition to shielding all penetrating wires must be protected from conducted transient interferences by an appropriate POE (point of entry) protection.
- Use tested, high quality POE (point of entry) protection elements for all wires entering an electromagnetic shield and install these as feed-through devices, e.g. the Meteolabor® USS-1, USS-2, USP, CSP or PLP series.

Ordering Information / Part Number

USS-2-TV75-BNC

Surge Protector / Filter EMP USS2-TV75-BNC

USS-SM2 optional slotted nut

USS-SK2 optional special socket spanner for slotted nut

Caution
 Maximum torque for installation screw shall not exceed 25 Nm

Contact

Meteolabor AG
 Hofstrasse 92
 CH-8620 Wetzikon
 Switzerland

Tel: +41 44 934 40 40
 E-Mail: info@meteolabor.ch
 Internet: www.meteolabor.ch

© by Meteolabor AG
 All rights reserved

Content may change without further notice 2023
 USS-2-TV75-BNC_e_V2023

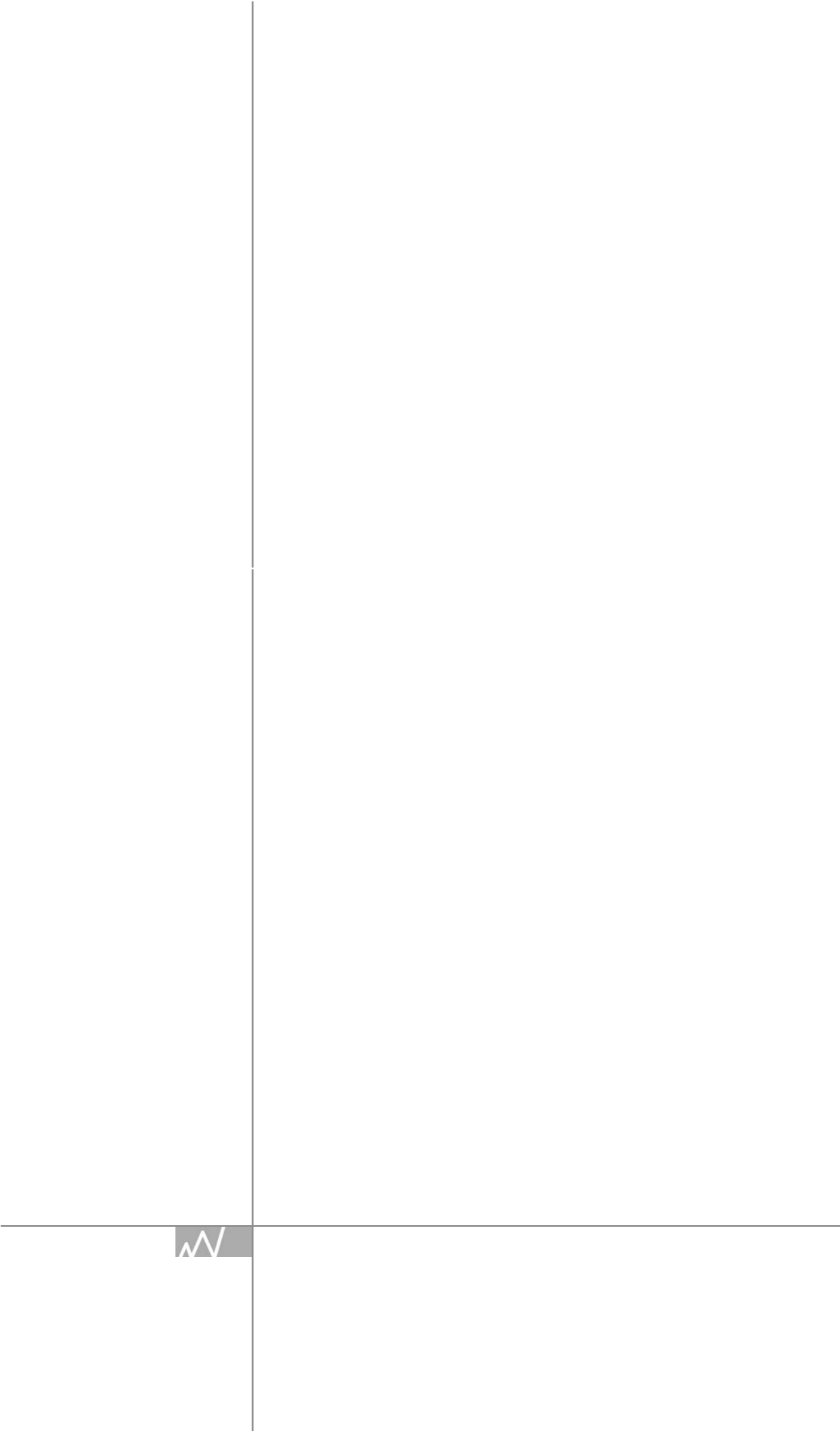

Various Well-Proven Circuits





Protection circuits against surge and interference voltage USS-8

The USS-8 protection circuit is designed for 8 independent signal lines

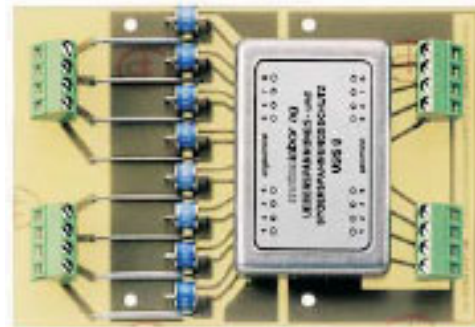

This surge and interference voltage protection circuits are mechanical units for the protection of eight independent signal lines or 4 x 2 power supply lines (current loops) from voltage surge as occurs with strokes of lightning. They consist basically of a printed circuit board on to which a combination of surge protectors with a special filter are built. The filter smooths voltage peaks building up to sparkover of the surge protector and further attenuates all high frequency interference signals over 100 kHz. By connecting RC elements or capacitors in series, the cut-off frequency can be reduced even further. With these protection circuits it is possible to protect highly sensitive equipment from malfunction or damage even if lightning strokes the signal or power supply lines directly.

Application

The Meteolabor USS-8 protection circuit is designed for 8 independent signal lines. When using two USS-8 protection circuit, the following values apply for 600 Ohm lines in the frequency range 300...3400 Hz.

In order not to influence the filter effect in the USS-4 x 2 protection circuit, the current in a double circuit must be exactly the same (current loop). It is designed for two-pole elements such as power supplies or symmetrical data transmission equipment.

Technical Data USS-8

Number of circuits	8
DC resistance per circuit	6,5 Ω
Insulation resistance to earth and neighbouring circuit (measuring voltage 12 V)	≥1 G Ω
Operating Voltage	max. ±150 VDC / 100 VAC
Current load per circuit	max. 350 mA
Total current load of all 8 circuits	max. 1.2 A
Max. output voltage upon voltage surge (without additional secondary protection Elements)	< 600 V
Rise time of output pulse	approx. 2 μs
Sparkover DC voltage	approx. 230 V
Glow discharge voltage (at 10 mA)	approx. 70 V
Arc discharge voltage (from approx. 0,5 A)	approx. 10 V
Impulse discharge current (8 / 20 μs)	20 kA
Terminals	1.5 mm ²
Dimensions	132,5 x 90 x 15 mm
Weight	approx. 160 g



Set-up for measuring attenuation and crosstalk

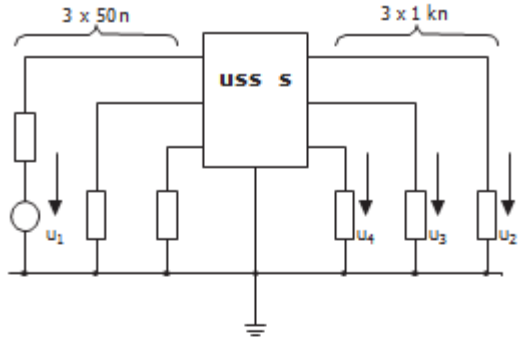

Crosstalk as a function of frequency

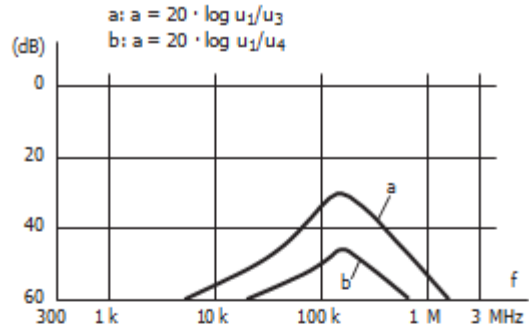

Overshoot by impulse operation

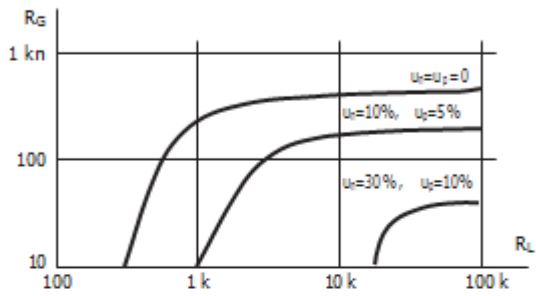
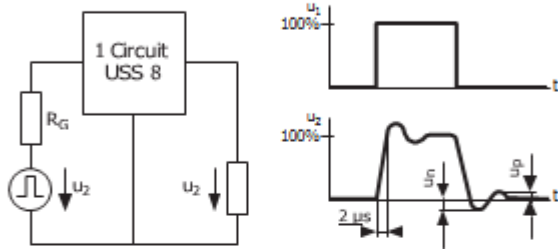

Crosstalk by impulse operation

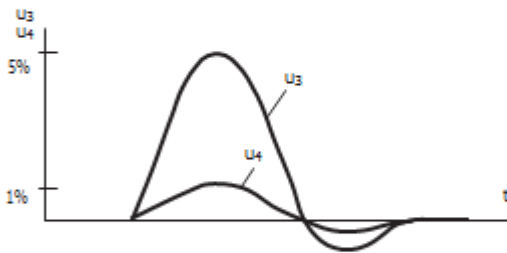
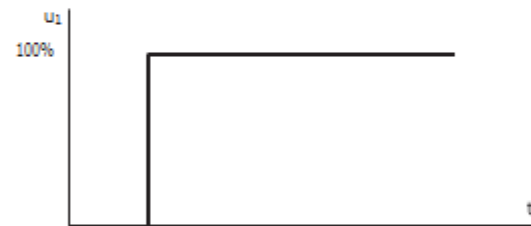

Dimensions of USS8

Weight: approx. 160g

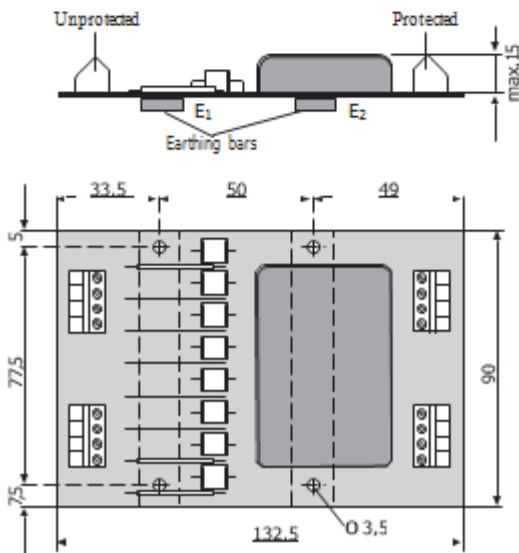

Ordering informations

- Surge protection USS8
- Earthing bar ES
- Earthing bar ESK

Earthing bar USS8

Nickel-plated
(2 required for each protection circuit)

Type Es

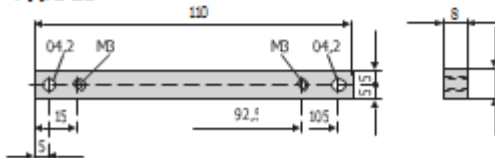

Type ESK

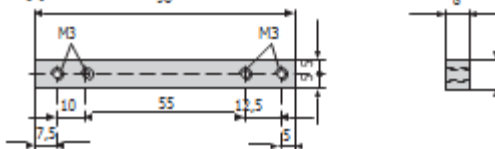

Ordering Information / Part Number

- USS-8** Surge protection
- USS4x2** Surge protection
- ES** Earthing bar
- ESK** Earthing bar

Caution
 For proper function unprotected / protected side must be installed correctly.

Contact

Meteolabor AG
 Hofstrasse 92
 CH-8620 Wetzikon
 Switzerland

Tel: +41 44 934 40 40
 E-Mail: info@meteolabor.ch
 Internet: www.meteolabor.ch

© by Meteolabor AG
 All rights reserved
 Content may change without further notice 2023-07
 USS-8_e_V2023



EMP Surge Protector/Filter 48 V DC, 10 A, 3-pol. VG-Buchse, USS-48V-10SL-3-EMP

**Überspannungsschutz/Filter für 48V DC
Kleinspannung, bis 10 A Nennstrom**

**Effektiver Schutz gegen Überspannungen durch
HEMP/NEMP oder Blitzschläge sowie HF-Störungen**

**Mehrstufiges Design mit Gleichtakt- und
differentiellem Schutz mit integriertem Filter**

**Einfache Montage als Durchführungselement in einer
metallischen Wand (Faraday Käfig)**

**Klare Trennung von geschützter (Gerätebuchse
10SL-3SN nach VG95234) und ungeschützter Seite**

Kompakte mechanische Einheit



Die Überspannungsschutzschaltung USS-48V-10SL-3-EMP vereinigt einen speziell für Kleinspannungen ausgelegten Überspannungsschutz mit integriertem Störspannungsfiler zur Dämpfung von Gleich- und Gegentaktstörungen.

Das hohe Ableitvermögen (bis zu 40 kA pro Leiter) bietet grösstmöglichen Schutz gegen schnelle, transiente Überspannungen wie sie durch HEMP/NEMP, Blitzschlag oder elektrische Schaltvorgänge hervorgerufen werden können.

Eine Gerätebuchse nach VG-Norm auf der geschützten Seite erlaubt den einfachen Anschluss von entsprechenden Kabelsteckern, wie sie z.B. in gepanzerten Fahrzeugen üblich sind.

Anwendungen

Überspannungsschutzschaltungen/Filter der USS-Serie sind optimiert für den Schutz empfindlicher Systeme und Anlagen gegen die Effekte von Überspannungen und schnellen Transienten.

Diese USS-Komponente ist besonders geeignet für den Einsatz in sensiblen Einrichtungen der Wehrtechnik, in sicherheitstechnischen Anlagen sowie speziell in mobilen bzw. portablen Einrichtungen und Systemen.

Die mechanische Auslegung dieser USS-Schutzschaltung als Durchführungselement erlaubt eine direkte Befestigung an einem Faraday-Käfig.

Technische Daten USS-48V-10SL-3-EMP

Nennbetriebsspannung U_N	48 V DC / 34 V AC	DC / 50/60 Hz
Max. Betriebsspannung U_c	56 V DC / 40 V AC	DC / 50/60 Hz
Nennstrom I_N	10 A	bei T_{amb} 65 °C
Ableitvermögen nominell I_n	25 kA	mehrmals, +/- → GND, Form 8/20 μ s, T_{amb} 40 °C
Ableitvermögen maximal I_{max}	40 kA	mindestens 1 mal, +/- → GND, Form 8/20 μ s, T_{amb} 40 °C
Restspannung	< 600 V	+, - → GND, Form 8/20 μ s, 25 kA
DC-Widerstand	typ. 30 m Ω	pro Pfad, T_{amb} 25 °C, mit 1 m Kabel
Anschluss ungeschützte Seite	Kabel, integriert	VG95218 schwarz, 1 m, 3 x AWG15, geschirmt
Anschluss geschützte Seite	Buchse	A-10SL-3SN
Anwendungsklasse	HPF	DIN 40040
Abmessungen	189 x 59 mm	Aussenabmessungen (Details siehe Zeichnung Rückseite)
Gewicht	ca. 1,3 kg	

Abmessungen

(UN0121)

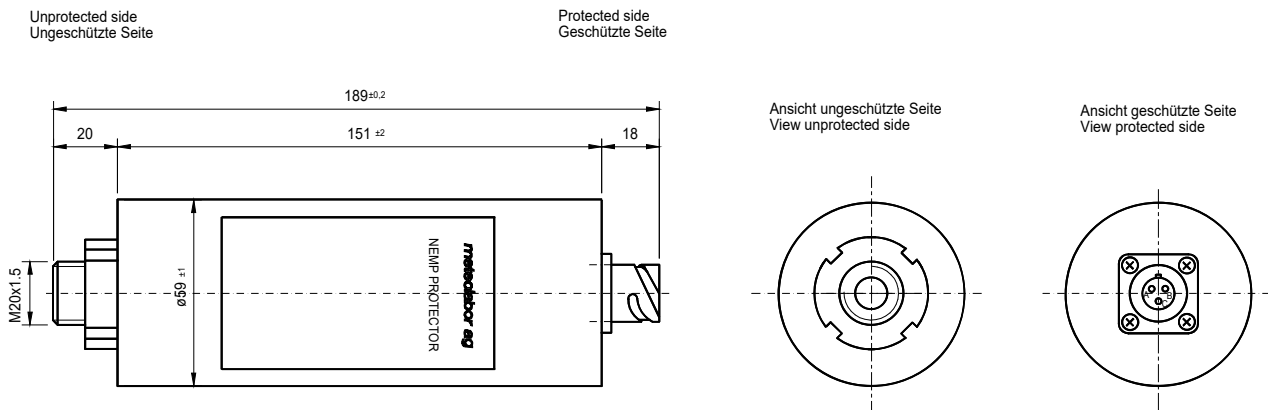

Installationshinweise

- Die lokal geltenden elektrischen Installations- und Sicherheitsvorschriften sind unbedingt einzuhalten.
- Zur Erfüllung der Personensicherheitsvorschriften ist eine sachgemäße Installation durch eine Fachperson notwendig.
- Von der USS-Schutzschaltung zur Erde muss eine niederimpedante, sichere elektrische Verbindung gegeben sein, um eine ausreichende Ableitung von Stossströmen zu gewährleisten.
- Nach einem Überspannungsereignis mit sichtbaren Schäden im geschützten oder ungeschützten Bereich des Systems muss eine Überprüfung des Schutzelements erfolgen.

Sicherheitshinweise

- Das Gehäuse enthält keine Austauschteile oder zu wartenden Komponenten.
- Bei Beschädigung der Prüfkleber und/oder bei unsachgemäßen Manipulationen am Element erlischt die Herstellergarantie, zudem kann dadurch die ordnungsgemäße Funktion der USS-Schutzschaltung beeinträchtigt werden.

Anschluss – ungeschützte Seite

(Kabel, integriert)

Kabelbelegung
 1 – Plus 48V (+)
 2 – Minus (-)
 3 – GND (Gehäuse)
 Schirm – GND (Gehäuse)

Anschluss – geschützte Seite

(Gerätebuchse VG234A-10SL-3SN)

Pole der Gerätebuchse
 A – Plus 48V (+)
 B – Minus (-)
 C – GND (Gehäuse)

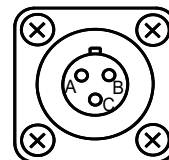

Bestellinformationen

Art.-Nr.: **USS-48V-10SL-3-EMP**Typ.-Nr.: **USS-48V-10SL-3-EMP**

Kontakt

Meteolabor AG
 Hofstrasse 92
 CH-8620 Wetzikon
 Switzerland

Phone: +41 44 934 40 40
 E-Mail: info@meteolabor.com
 Internet: www.meteolabor.com

© by Meteolabor AG
 Alle Rechte vorbehalten.

Wird bei Änderung nicht erfasst • 2023-07
 USS-48V-10SL-3-EMP_d_V2023

EMP Surge Protector/Filter 400 V AC, 16 A USS3x400/230V/16A/EMP/AC

Overvoltage protector / filter for three phases and neutral 400 / 230 VAC, 50 / 60 Hz power supply lines, up to 16 A

Multi-stage design with common-mode and differential mode protection and integrated filter

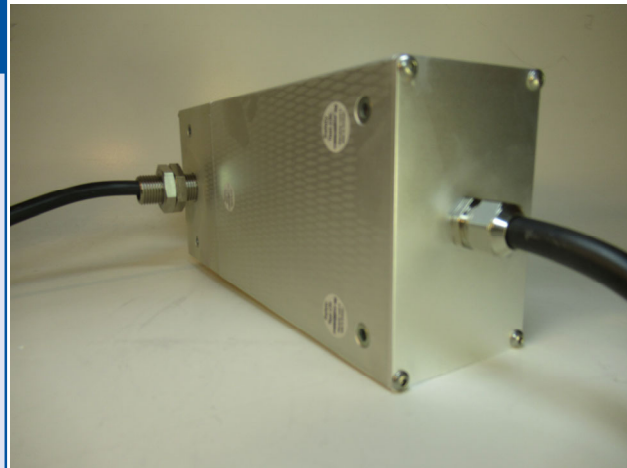

Product

The Meteolabor USS-3x400/230V/16A/EMP/AC surge protector / filter is specially designed for overvoltage protection of power supply lines plus additionally contains an integrated filter for the attenuation of common and differential mode interferences.

The capability to handle high surge currents (up to 40 kA per conductor) ensures best protection against very fast transient overvoltages as they can be generated by NEMP / HEMP, lightning or switching.

Because of their very low leakage current USS series protectors are ideally suited for mobile/portable systems and applications.

Applications

Surge protector filter elements of the USS series are optimized to protect sensitive units and systems against the effects of overvoltages and fast transients.

USS elements are specially suited to be used in sensitive and mission-critical defence systems (command and control systems, communication, IT installations aso.), in security installations, telecommunication equipment etc. The USS-series has been successfully used in many projects, where EMP-tests according to RS105 or similar, were done.

The universal mechanical design of the USS series offers various ways of mounting the unit as a feed-through component in a Faraday cage. No matter if this is a fixed installation (building, underground shelter) or a mobile container or vehicle

Technische Daten USS-3x400/230V/16A/EMP/AC

Nominal operating voltage UN	3 x 400 / 230 V AC	50 / 60 Hz
Number of paths	4	(L1, L2, L3, N)
Nominal current I _N	16 A	RMS, at T _{amb} 45°C
Max surge current I _{max}	40 kA	min one strike, L / N → PE, shape 8 / 20 μs, T _{amb} 40°C
Residual voltage against ground	< 1.8 kV	L → PE, shape 8 / 20 μs
Residual voltage L → N	< 1.0 kV	L → PE, shape 8 / 20 μs, 25kA
AC leakage current	< 3.5 mA	L → PE at U _N , 50 Hz
Insertion loss (common mode)	< 60 dB	(10 MHz – 2.9 GHz)
Connection unprotected	cable	Output angled
Case material		Passivated aluminium
Dimensions	244 x110.2x70.4 mm	major dimensions (details see drawing on rear side)
Weight	ca. 2 kg	

Dimensions

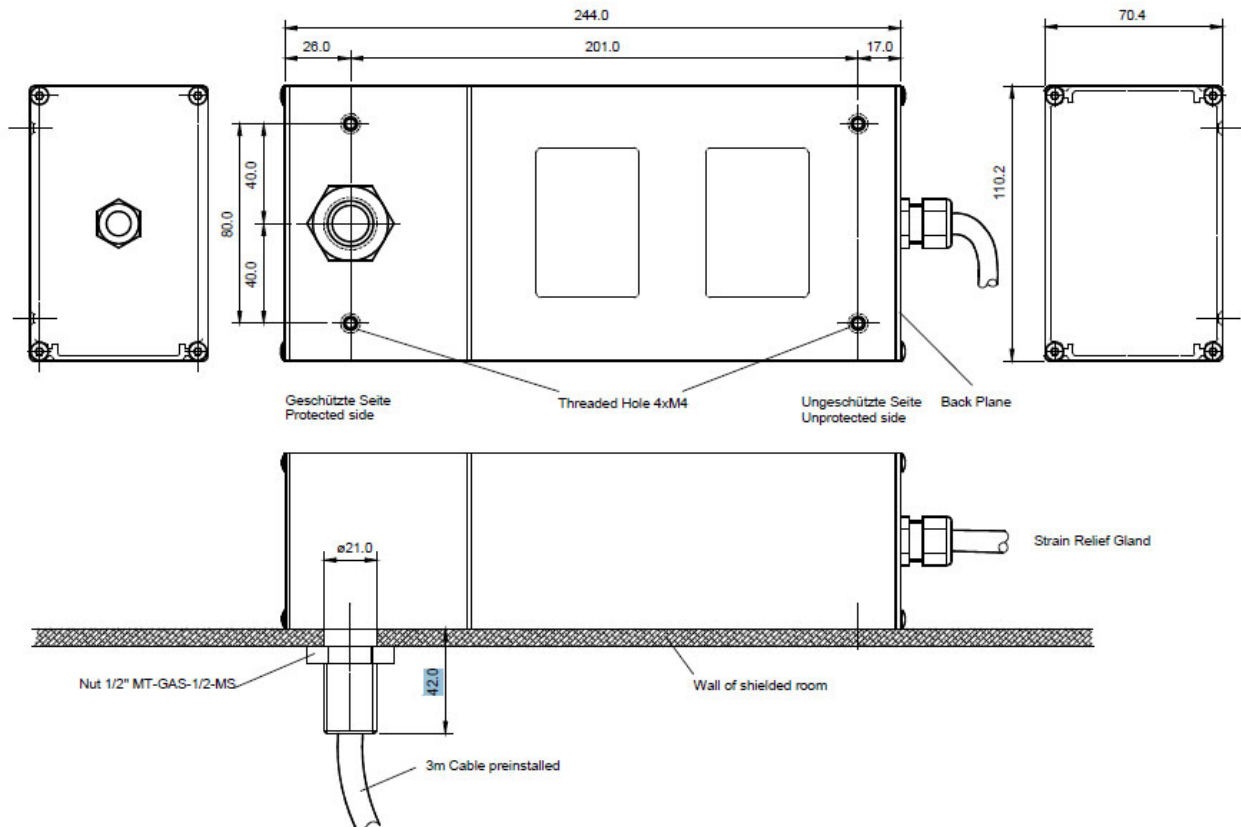

Installation Instructions

- The USS surge protector / filter has to be installed by electrically skilled personnel only.
- The electrical wiring of the unit has to be done according to the national standards and safety regulations.
- Always install Ground / Protective Earth first.
- From the USS surge protector / filter case a secure, low impedance connection to earth has to be made to ensure sufficient flow of discharge surge currents.

Safety Notes

- Before opening the cover plate of the terminal area make sure that power is switched off.
- The unit does not contain any serviceable parts. Do not attempt to open the device, only the cover plate of the terminal area is allowed to be opened temporarily in order to install the cables. Close before switching on.
- Unauthorized manipulation or damaging of the labels can lead to malfunction or destruction of the USS surge protector/filter and will result in loss of warranty.
- After an overvoltage event causing visible damages in the protected or unprotected area, the protector/filter unit has to be tested or replaced

Bestellinformationen

Art.-Nr.: USS3x400/230V/16A/EMP/AC

Kontakt

Meteolabor AG
Hofstrasse 92
CH-8620 Wetzikon
Switzerland

Phone: +41 44 934 40 40
E-Mail: info@meteolabor.com
Internet: www.meteolabor.com

© by Meteolabor AG
Alle Rechte vorbehalten.

2023-07
USS3x400-230V-16A-EMP-AC_e_V2023

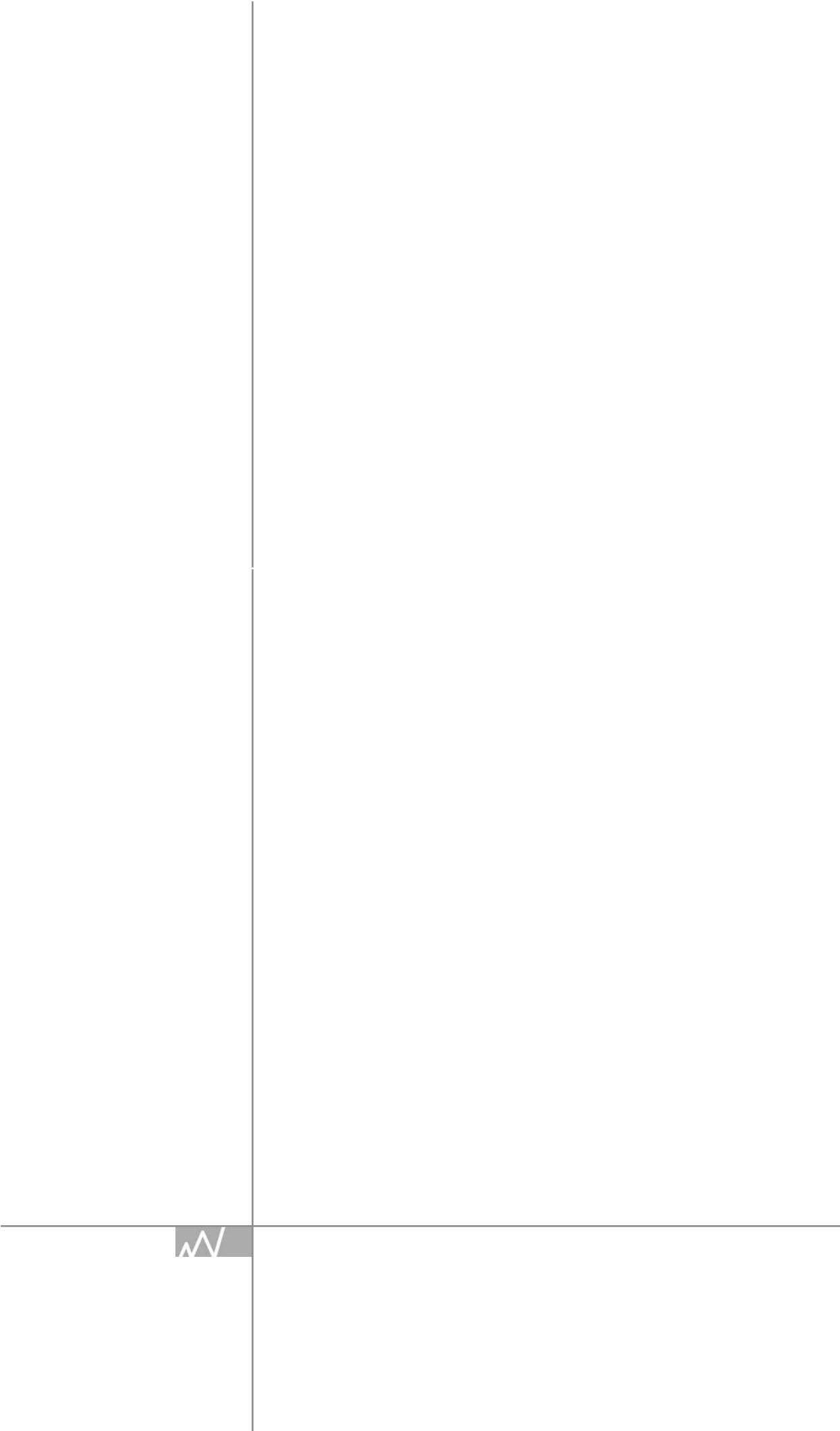



USN - Series

Lightning and EMP-Protection of Dedicated Datalines





EMP Surge Protector / Filter 2x VDSL / ADSL / ISDN / POTS USN-22001

Excellent lightning and EMP protection for two subscriber lines in a single case for POTS (analog Telephone), ISDN, xDSL (DSL, ADSL, VDSL)

WAGO MCS Micro terminal block, locking lever

Protects against overvoltages produced by NEMP / HEMP, lightning or other transients

Multi-stage protection/filter design with high transient energy absorption capability

Feed-through installation into wall of Faraday cage

Threat-level tested against HEMP according to MIL-STD-188-125. For details see chapter "3 User Information"



Product

The Meteolabor USN-series protection circuits against surge and interference voltages are designed as feed-through type mechanical units for the protection of data and control line systems. Depending on the specific application different types are available.

The highly effective multi-stage transient protection design combined with filtering components provides excellent protection against the effects of atmospheric discharges (lightning, electrostatic discharge) or a High Altitude Electro-Magnetic Pulse (HEMP), sometimes also referred to as Nuclear Electro-Magnetic Pulse (NEMP) or simply EMP. Special features of this series of protection circuits include high surge current capability, compact feed-through design and simple installation directly to Faraday cage.

Applications

Meteolabor USN-22001 protects two telephone wire pairs of analog or digital telephone subscriber lines (POTS, ISDN, DSL, ADSL, VDSL) against the effects of lightning and EMP.

USN-22001 has pluggable WAGO MCS Micro terminal blocks with locking levers and CAGE CLAMP® contacts. The wires are easy to install by using the supplied operating tool or a matching screw driver.

For best protection results a feed-through installation from an unprotected volume into a shielded and protected room is recommended.

USN-22001 protector / filter is designed to be used in fixed installations (buildings, underground shelters etc.) as well as in portable and mobile systems like containers or shelters and vehicles, which need to be EMP-tested according to RS105 of MIL-STD-461F.

Technical Data USN-22001

Application	2 Subscriber lines	2 pairs of telephone (POTS, ISDN, xDSL (DSL, ADSL, VDSL))
Max. operating voltage	±160 V	Peak signal voltage between wire pairs 1 - 2, 4 - 5, pin 3 = GND/case
Max. operating current	250 mA	Each wire
Bandwidth	>30 MHz	Differential signals between pairs 1 - 2 and 4 - 5
Max. surge current I_{Max}	4 x 10 kA	Each wire → ground/case, shape 8 / 20 μs, at least 1 pulse
Max. lightning impulse current I_{Imp}	2 x 2 kA	Each wire → ground/case, shape 10 / 350 μs, at least 1 pulse
DC resistance input - output	7 Ω typically	Each wire pin 1,2,4,5; pin 3 = Ground / case
Residual voltage common mode surge	< 240 V typically	pair → ground / case, pulse 4 kV / 2 kA according to IEC 61000-4-5
Residual voltage fast rising pulse	< 320 V typically	wire → ground / case, fast pulse 4 kV, 5 / 50 ns, load 1 MOhms
Residual voltage differential mode	< 290 V typically	Between wire pair, pulse 4 kV / 2 kA according to IEC 61000-4-5
Connection terminals	WAGO MCS Micro	Pluggable terminal block, locking lever, CAGE CLAMP®, 0.08–0.5mm ²
Case material	Brass	Nickel-plated
Temperature range	- 40° C / +85° C	
Max. allowed installation torque	30 Nm	Not to be exceeded under all circumstances
Dimensions	Ø 32 x 112.5 mm	2 nuts M32 x 1.5 for feed-through installation
Weight	approx. 250 g	Incl. 2 nuts

Dimensions [mm]

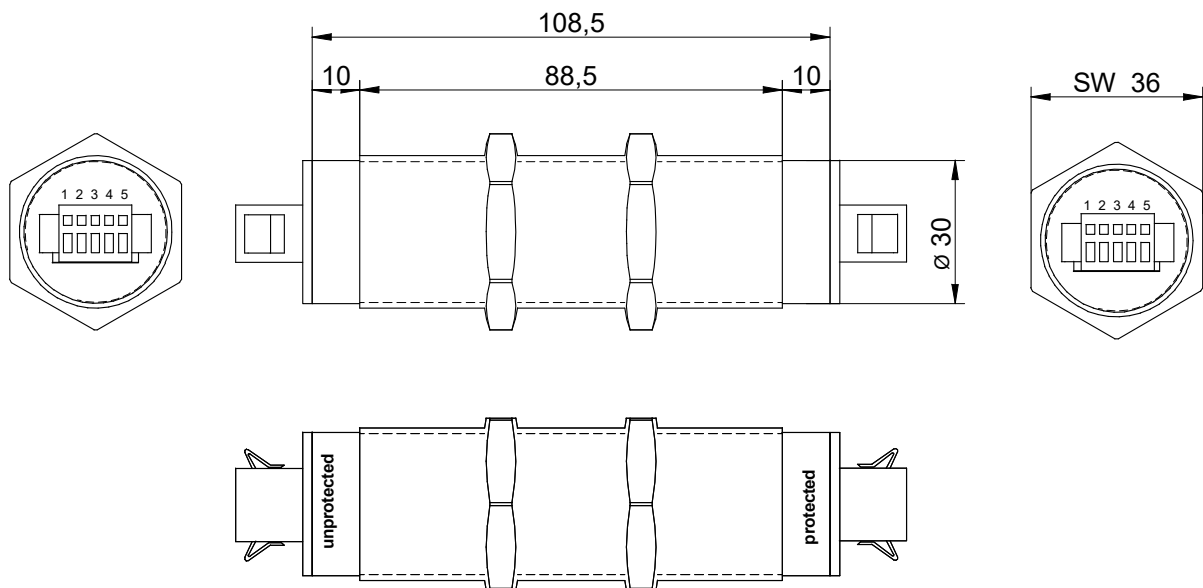

NOTE: Use always 1 - 2 (or 4 - 5) as wire pairs, Pin 3 is GND/case for optional ground / or shield connection

Installation Notes

- The USN-series EMP protector / filters shall be installed by electrically skilled personnel.
- The electrical wiring must be done according to local regulations.
- The max. values stated in this datasheet must not be exceeded under any circumstances.
- Do not exceed max. installation torque of 30 Nm as this can destroy the device.
- USN-series EMP protector / filters may be directly installed into the wall of a Faraday cage as feed-through device.
- Strip wires 5 - 6 mm (solid or stranded) and insert into terminal block with or without ferrule by using the insulated operating tool supplied or an appropriate screw driver.

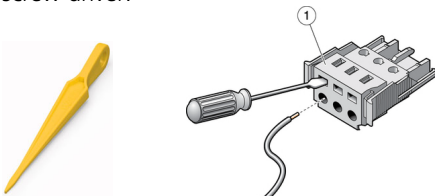

Ordering Information / Part Number

USN-22001 EMP Surge Protector/Filter
for 2 pairs of telephone (analog, ISDN, xDSL)

General Recommendations for Protection Installation

- In order to achieve the full performance of a protection circuit the application of good - practice EMC design techniques is necessary for the whole system to be protected.
- For EMP - protection usually a shield as an electromagnetic barrier to protect a certain volume is necessary. This shield avoids coupling of radiated disturbances inside the protected volume. In addition to shielding all penetrating wires must be protected from conducted transient interferences by an appropriate POE (point of entry) protection.
- Use tested, high quality POE (point of entry) protection elements for all wires entering an electromagnetic shield and install these as feed-through devices, e.g. the Meteolabor® USS-1, USS-2, USN, USP, CSP or PLP series.



Caution

Maximum torque for installation screw shall not exceed 30 Nm

Contact

Meteolabor AG
Hofstrasse 92
CH-8620 Wetzikon
Switzerland

Tel: +41 44 934 40 40
E-Mail: info@meteolabor.ch
Internet: www.meteolabor.ch

© by Meteolabor AG
All rights reserved

Content may change without further notice 2023-07
USN-22001_e_V2023



EMP Surge Protector / Filter 10 / 100 Mb/s Ethernet, RJ45 Jacks USN-40001

Excellent lightning and EMP protection for two twisted pairs of a 10 / 100 Mbit/s Ethernet link using RJ45 input and output jacks

Protects against overvoltages produced by NEMP / HEMP, lightning or other transients

Multi-stage protection / filter design with high transient energy absorption capability and isolated input and output

Feed-through type nickel-plated body for direct installation to wall of Faraday cage

Threat-level tested against HEMP according to MIL-STD-188-125. For details see chapter "3 User Information"



Product

The Meteolabor USN-series protection circuits against surge and interference voltages are designed as feed-through type mechanical units for the protection of data and control line systems. Depending on the specific application different types are available.

The highly effective multi-stage transient protection design combined with filtering components provides excellent protection against the effects of atmospheric discharges (lightning, electrostatic discharge) or a High Altitude Electro-Magnetic Pulse (HEMP), sometimes also referred to as Nuclear Electro-Magnetic Pulse (NEMP) or simply EMP. Special features of this series of protection circuits include high surge current capability, compact feed-through design and simple installation directly to Faraday cage.

Applications

Meteolabor USN-40001 combines the protection of two pieces Meteolabor® USS-2-AQ in one case to provide excellent protection for two twisted pairs of a 10 / 100 Mbit/s Ethernet connection of sensitive electronics such as computers, telecommunication equipment etc. against the effects of lightning and EMP.

USN-40001 has shielded RJ45 jacks and can be easily installed by using of-the-shelf patch cables. For best results shielded cables are recommended.

Input and output of USN-40001 are isolated by a magnetic circuit which provides best protection and filtering effect in a feed-through installation from an unprotected volume into a shielded and protected room. However, PoE (Power over Ethernet) is not possible with USN-40001.

USN-40001 protector / filter is designed to be used in fixed installations (buildings, underground shelters etc.) as well as in portable and mobile systems like containers or shelters and vehicles, which need to be EMP-tested according to RS105 of MIL-STD-461F.

Technical Data USN-40001

Application	Ethernet protection	10 / 100 Mbit/s, not applicable for Power over Ethernet (PoE)
Max. operating voltage	±3V	Peak voltage between wire pairs 1 - 2 and 3 - 6; wire pairs 4 - 5 and 7 - 8 are not connected
Data rate	10 / 100 Mbit/s	Ethernet or Fast Ethernet as per IEEE 802.3
Max. surge current I_{Max}	2 x 10 kA *)	Each wire → ground / case, shape 8/20 μs, at least 1 pulse *) surge currents >2 kA (8 / 20 μs) per wire may damage RJ45 contacts
Max. lightning impulse current I_{Imp}	2 x 2 kA *)	Each wire → ground/case, shape 10 / 350 μs, at least 1 pulse
DC resistance input - output	Open circuit	Input / output isolated
Residual voltage common mode	< 20 V	Wires → ground / case, pulse 4 kV / 2 kA according to IEC 61000-4-5
Residual voltage differential mode	< 20 V	Between wire pair, pulse 4 kV / 2 kA according to IEC 61000-4-5
Connection terminals	RJ45 shielded	Use of shielded cables recommended
Case material	Brass	Nickel-plated
Temperature range	- 40° C / +85° C	
Max. allowed installation torque	30 Nm	Not to be exceeded under all circumstances
Dimensions	Ø 32 x 112.5 mm	2 nuts M32 x 1.5, see drawing for details
Weight	approx. 250 g	Incl. 2 nuts

Dimensions [mm]

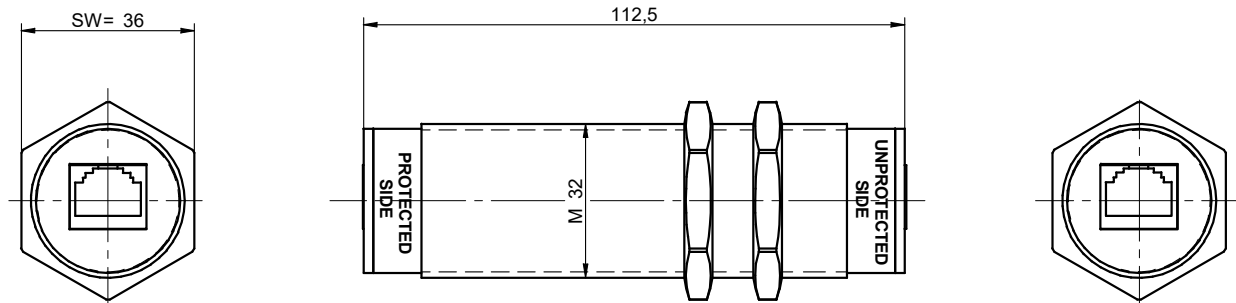

Note: Pins 4, 5, 7 and 8 of RJ45 socket are not required for 10 / 100Mbit/s and are not connected

Installation Notes

- The USN-series EMP protector / filters shall be installed by electrically skilled personnel.
- The electrical wiring must be done according to local regulations.
- The max. values stated in this datasheet must not be exceeded under any circumstances.
- Do not exceed max. installation torque of 30 Nm as this can destroy the device.
- USN-series EMP protector / filters may be directly installed into the wall of a Faraday cage as feed-through device. For best performance the cabling should be shielded at least on the protected side.

General Recommendations for Protection Installation

- In order to achieve the full performance of a protection circuit the application of good-practice EMC design techniques is necessary for the whole system to be protected.
- For EMP-protection usually a shield as an electromagnetic barrier to protect a certain volume is necessary. This shield avoids coupling of radiated disturbances inside the protected volume. In addition to shielding all penetrating wires must be protected from conducted transient interferences by an appropriate POE (point of entry) protection.
- Use tested, high quality POE (point of entry) protection elements for all wires entering an electromagnetic shield and install these as feed-through devices, e.g. the Meteolabor® USS-1, USS-2, USP, CSP or PLP series.

Ordering Information / Part Number

USN-40001 EMP Protector / Filter 10 / 100 Mbit/s Ethernet

Note: USN-40001 replaces 2 pieces of EMP protector USS-2-AQ (NSN-Nr. 5920-12-354-9312)



Caution

Maximum torque for installation screw shall not exceed 30 Nm

Contact

Meteolabor AG
Hofstrasse 92
CH-8620 Wetzikon
Switzerland

Tel: +41 44 934 40 40
E-Mail: info@meteolabor.ch
Internet: www.meteolabor.ch

© by Meteolabor AG
All rights reserved

Content may change without further notice 2023-07
USN-40001_e_V2023



EMP Surge Protector / Filter RS422 / RS485 / PROFIBUS USN-40002

Excellent lightning and EMP protection for two wire pairs in a single case for RS422 / RS485 / PROFIBUS interfaces

WAGO MCS Micro terminal block, locking lever

Protects against overvoltages produced by NEMP / HEMP, lightning or other transients

Multi-stage protection/filter design with high transient energy absorption capability

Feed-through installation into wall of Faraday cage

Threat-level tested against HEMP according to MIL-STD-188-125. For details see chapter "3 User Information"



Product

The Meteolabor USN-series protection circuits against surge and interference voltages are designed as feed-through type mechanical units for the protection of data and control line systems. Depending on the specific application different types are available.

The highly effective multi-stage transient protection design combined with filtering components provides excellent protection against the effects of atmospheric discharges (lightning, electrostatic discharge) or a High Altitude Electro-Magnetic Pulse (HEMP), sometimes also referred to as Nuclear Electro-Magnetic Pulse (NEMP) or simply EMP. Special features of this series of protection circuits include high surge current capability, compact feed-through design and simple installation directly to Faraday cage.

Applications

Meteolabor USN-40002 protects two wire pairs of RS422 / RS485 / PROFIBUS interfaces against the effects of lightning and EMP. It replaces the Meteolabor® USS-4-RS422/485/FD in a much smaller case and has even better performance.

USN-40002 has pluggable WAGO MCS Micro terminal blocks with locking levers and CAGE CLAMP® contacts. The wires are easy to install by using the supplied operating tool or a matching screw driver.

For best protection results a feed-through installation from an unprotected volume into a shielded and protected room is recommended.

USN-40002 protector / filter is designed to be used in fixed installations (buildings, underground shelters etc.) as well as in portable and mobile systems like containers or shelters and vehicles, which need to be EMP-tested according to RS105 of MIL-STD-461F.

Technical Data USN-40002

Application	Protects 2 wire pairs	Of RS422 / RS485 / PROFIBUS
Max. operating voltage	6 V	Peak-to-peak balanced signal voltage between wire pairs 1 - 2, 4 - 5
Max. operating current	100 mA	Each wire pin 1,2,4,5; pin 3 is connected to ground/case
Data rate	Up to 12 Mbit/s	Effective data rate depends on wiring length
Max. surge current I_{Max}	4 x 10 kA	Each wire → ground / case, shape 8 / 20 μs, at least 1 pulse
Max. lightning impulse current I_{Imp}	2 x 2 kA	Each wire → ground / case, shape 10 / 350 μs, at least 1 pulse
DC resistance input - output	6 Ω typically	Each wire pin 1,2,4,5; pin 3 is connected to ground/case
Residual voltage surge	< 240 V typically	wire → ground / case, pulse 4 kV / 2 kA according to IEC 61000-4-5
Residual voltage fast rising pulse	< 320 V typically	wire → ground / case, fast pulse 4 kV, 5 / 50ns, load 1 MOhms
Residual voltage differential mode	< 23 V typically	Between wire pair, pulse 4 kV / 2 kA according to IEC 61000-4-5
Connection terminals	WAGO MCS Micro	Pluggable terminal block, locking lever, CAGE CLAMP®, 0.08–0.5mm ²
Case material	Brass	Nickel-plated
Temperature range	- 40° C / +85° C	
Max. allowed installation torque	30 Nm	Not to be exceeded under all circumstances
Dimensions	Ø 32 x 112.5 mm	2 nuts M32 x 1.5 for feed-through installation
Weight	approx. 250 g	Incl. 2 nuts

Dimensions [mm]

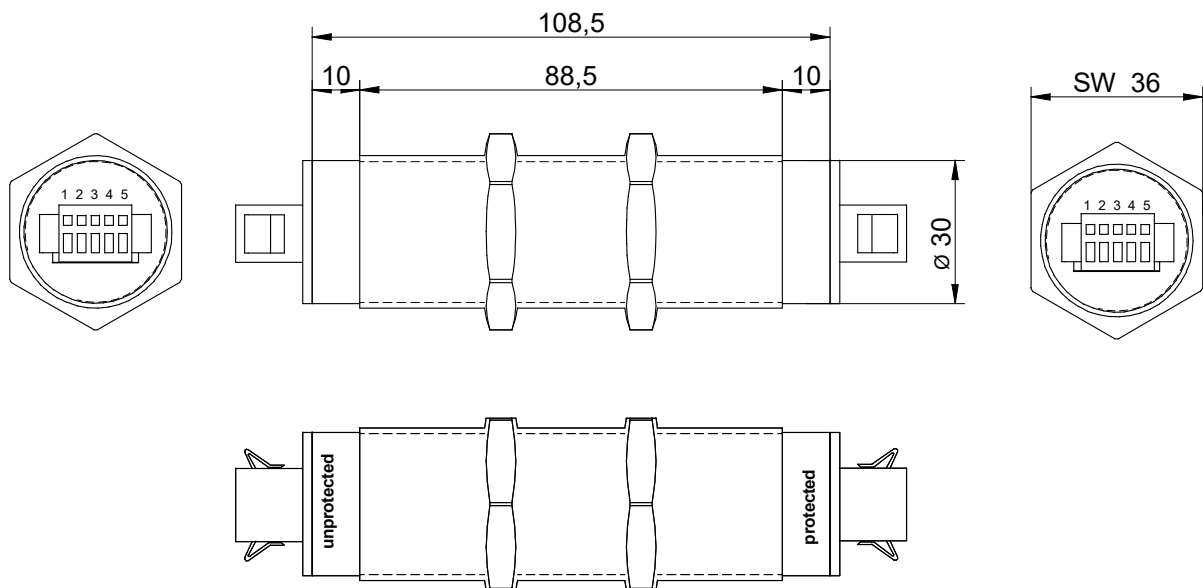

NOTE: Use always 1 - 2 (or 4 - 5) as wire pairs, Pin 3 is GND / case for optional ground / or shield connection

Installation Notes

- The USN-series EMP protector / filters shall be installed by electrically skilled personnel.
- The electrical wiring must be done according to local regulations.
- The max. values stated in this datasheet must not be exceeded under any circumstances.
- Do not exceed max. installation torque of 30 Nm as this can destroy the device.
- USN-series EMP protector / filters may be directly installed into the wall of a Faraday cage as feed-through device.
- Strip wires 5 - 6 mm (solid or stranded) and insert into terminal block with or without ferrule by using the insulated operating tool supplied or an appropriate screw driver.

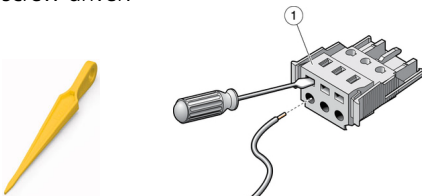

Ordering Information / Part Number

USN-40002 EMP Surge Protector / Filter
for 2 pairs of RS422/RS485 interface
Replaces USS-4-RS422/485/FD

General Recommendations for Protection Installation

- In order to achieve the full performance of a protection circuit the application of good - practice EMC design techniques is necessary for the whole system to be protected.
- For EMP - protection usually a shield as an electromagnetic barrier to protect a certain volume is necessary. This shield avoids coupling of radiated disturbances inside the protected volume. In addition to shielding all penetrating wires must be protected from conducted transient interferences by an appropriate POE (point of entry) protection.
- Use tested, high quality POE (point of entry) protection elements for all wires entering an electromagnetic shield and install these as feed-through devices, e.g. the Meteolabor® USS-1, USS-2, USN, USP, CSP or PLP series.



Caution

Maximum torque for installation screw shall not exceed 30 Nm

Contact

Meteolabor AG
Hofstrasse 92
CH-8620 Wetzikon
Switzerland

Tel: +41 44 934 40 40
E-Mail: info@meteolabor.ch
Internet: www.meteolabor.ch

© by Meteolabor AG
All rights reserved

Content may change without further notice 2023-07
USN-40002_e_V2027



EMP Surge Protector / Filter 10/100/1000 Mb/s Ethernet, PoE USN-80001

Excellent lightning and EMP protection for four twisted pairs of a 10 / 100 / 1000 Mbit/s Ethernet link works also with PoE (Power over Ethernet)

RJ45 input and output jacks

Protects against overvoltages produced by NEMP / HEMP, lightning or other transients

Multi-stage protection/filter design with high transient energy absorption capability

Feed-through installation into wall of Faraday cage

Threat-level tested against HEMP according to MIL-STD-188-125. For details see chapter "3 User Information"



Product

The Meteolabor USN-series protection circuits against surge and interference voltages are designed as feed-through type mechanical units for the protection of data and control line systems. Depending on the specific application different types are available.

The highly effective multi-stage transient protection design combined with filtering components provides excellent protection against the effects of atmospheric discharges (lightning, electrostatic discharge) or a High Altitude Electro-Magnetic Pulse (HEMP), sometimes also referred to as Nuclear Electro-Magnetic Pulse (NEMP) or simply EMP. Special features of this series of protection circuits include high surge current capability, compact feed-through design and simple installation directly to Faraday cage.

Applications

Meteolabor USN-80001 protects all four twisted pairs of a 10 / 100 / 1000 Mbit/s Ethernet connection of sensitive electronics such as computers, telecommunication equipment etc. against the effects of lightning and EMP.

USN-80001 has shielded RJ45 jacks and can be easily installed by using of-the-shelf patch cables. For best result shielded cables and a feed-through installation from an unprotected volume into a shielded and protected room are recommended.

USN-80001 also transmits up to 55 V DC and can be used for PoE applications according to IEEE 802.3af.

USN-80001 protector / filter is designed to be used in fixed installations (buildings, underground shelters etc.) as well as in portable and mobile systems like containers or shelters and vehicles, which need to be EMP-tested according to RS105 of MIL-STD-461F.

Technical Data USN-80001

Application	Ethernet protection	10/100/1000 Mbit/s, works also with Power over Ethernet (PoE)
Max. operating voltage	± 3 V ± 55 V	Peak signal voltage between wire pairs 1 - 2, 3 - 6, 4 - 5 and 7 - 8 Max. DC voltage pair to pair and pair to ground (PoE IEEE 802.3af)
Max. operating current	250 mA	Each wire
Data rate	10/100/1000 Mbit/s	Ethernet, Fast Ethernet or Gigabit Ethernet as per IEEE 802.3
Max. surge current I_{Max}	2 x 10 kA *)	Each wire → ground / case, shape 8 / 20 μ s, at least 1 pulse *) surge currents >2 kA (8 / 20 μ s) per wire may damage RJ45 contacts
Max. lightning impulse current I_{Imp}	2 x 2 kA *)	Each wire → ground/case, shape 10 / 350 μ s, at least 1 pulse
DC resistance input - output	< 6 Ω	Each wire
Residual voltage common mode surge	< 100 V typically	pair → ground / case, pulse 4 kV / 2 kA according to IEC 61000-4-5
Residual voltage common mode fast	< 300 V typically	pair → ground / case, fast pulse 4 kV, 5 / 50ns, load 1 MOhms
Residual voltage differential mode	< 20 V typically	Between wire pair, pulse 2 kV / 1 kA according to IEC 61000-4-5
Connection terminals	RJ45 shielded	Use of shielded cables recommended
Case material	Brass	Nickel-plated
Temperature Range	- 40° C / +85° C	
Max. allowed installation torque	30 Nm	Not to be exceeded under all circumstances
Dimensions	\varnothing 32 x 112.5 mm	2 nuts M32 x 1.5 for feed-through installation
Weight	approx. 250 g	Incl. 2 nuts

Dimensions [mm]

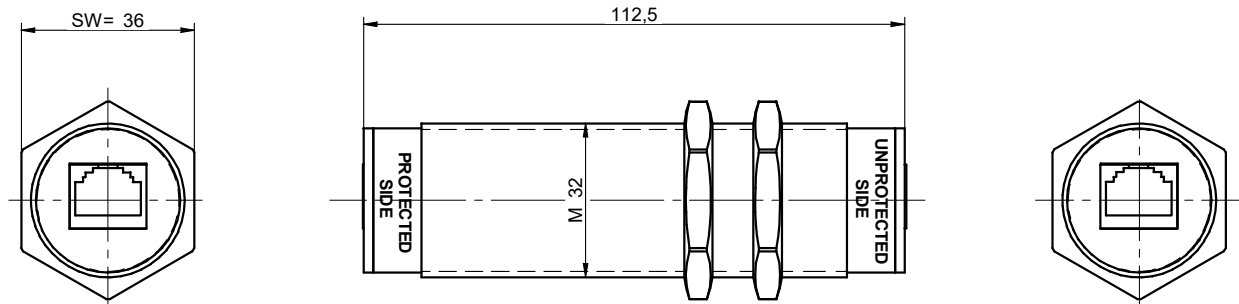

Use always 1 - 2, 3 - 6, 4 - 5 and 7 - 8 as wire pairs (same as in standard Ethernet connections)

Installation Notes

- The USN-series EMP protector / filters shall be installed by electrically skilled personnel.
- The electrical wiring must be done according to local regulations.
- The max. values stated in this datasheet must not be exceeded under any circumstances.
- Do not exceed max. installation torque of 30 Nm as this can destroy the device.
- USN-series EMP protector / filters may be directly installed into the wall of a Faraday cage as feed-through device. For best performance the cabling should be shielded at least on the protected side.

General Recommendations for Protection Installation

- In order to achieve the full performance of a protection circuit the application of good-practice EMC design techniques is necessary for the whole system to be protected.
- For EMP-protection usually a shield as an electromagnetic barrier to protect a certain volume is necessary. This shield avoids coupling of radiated disturbances inside the protected volume. In addition to shielding all penetrating wires must be protected from conducted transient interferences by an appropriate POE (point of entry) protection.
- Use tested, high quality POE (point of entry) protection elements for all wires entering an electromagnetic shield and install these as feed-through devices, e.g. the Meteolabor® USS-1, USS-2, USP, CSP or PLP series.

Ordering Information / Part Number

USN-80001 EMP Protector / Filter
10 / 100 / 1000 Mbit/s Ethernet / PoE



Caution

Maximum torque for installation screw shall not exceed 30 Nm

Contact

Meteolabor AG
Hofstrasse 92
CH-8620 Wetzikon
Switzerland

Tel: +41 44 934 40 40
E-Mail: info@meteolabor.ch
Internet: www.meteolabor.ch

© by Meteolabor AG
All rights reserved

Content may change without further notice 2023-07
USN-80001_e_V2023

EMP Surge Protector / Filter 10/100/1000 Mb/s Ethernet, PoE USN-80011

Excellent lightning and EMP protection for four twisted pairs of a 10 / 100 / 1000 Mbit/s Ethernet link works also with PoE (Power over Ethernet)

MIL input and output plug.

Protects against overvoltages produced by NEMP / HEMP, lightning or other transients

Multi-stage protection / filter design with high transient energy absorption capability

Feed-through installation into wall of Faraday cage

Threat - level tested against HEMP according to MIL-STD-188-125 For details see chapter „3 User Information“



Product

The Meteolabor USN-series protection circuits against surge and interference voltages are designed as feed-through type mechanical units for the protection of data and control line systems. Depending on the specific application different types are available.

The highly effective multi-stage transient protection design combined with filtering components provides excellent protection against the effects of atmospheric discharges (lightning, electrostatic discharge) or a High Altitude Electro-Magnetic Pulse (HEMP), sometimes also referred to as Nuclear Electro-Magnetic Pulse (NEMP) or simply EMP.

Special features of this series of protection circuits include high surge current capability, compact feed-through design and simple installation directly to Faraday cage.

Applications

Meteolabor USN-80011 protects all four twisted pairs of a 10 / 100 / 1000 Mbit/s Ethernet connection of sensitive electronics such as computers, telecommunication equipment etc. against the effects of lightning and EMP.

USN-80011 uses Bernier IP67 plugs. For best result shielded cables and a feed-through installation from an unprotected volume into a shielded and protected room are recommended.

USN-80011 also transmits up to 50V DC and can be used for PoE applications according to IEEE 802.3af.

USN-80011 protector / filter is designed to be used in fixed installations (buildings, underground shelters etc.) as well as in portable and mobile systems like containers or shelters and vehicles, which need to be EMP-tested according to RS105 of MIL-STD-461F.

Technical Data USN-80011

Application	Ethernet protection	10/100/1000 Mbit/s, works also with Power over Ethernet (PoE)
Max. operating voltage	± 3 V ± 55 V	Peak signal voltage between wire pairs Max. DC voltage pair to pair and pair to ground (PoE IEEE 802.3af)
Max. operating current	250 mA	Each wire
Data rate	10/100/1000 Mbit/s	Ethernet, Fast Ethernet or Gigabit Ethernet as per IEEE 802.3
Max. surge current I_{Max}	2×10 kA *)	Each wire \rightarrow ground / case, shape 8 / 20 μ s, at least 1 pulse
Max. lightning impulse current I_{Imp}	2×2 kA *)	Each wire \rightarrow ground / case, shape 10 / 350 μ s, at least 1 pulse
DC resistance input - output	< 6 Ω	Each wire
Residual voltage common mode surge	< 100 V typically	pair \rightarrow ground / case, pulse 4 kV / 2 kA according to IEC 61000-4-5
Residual voltage common mode fast	< 300 V typically	pair \rightarrow ground / case, fast pulse 4 kV, 5/50ns, load 1 MOhms
Residual voltage differential mode	< 20 V typically	Between wire pair, pulse 2 kV / 1 kA according to IEC 61000-4-5
Connection terminals	Bernier IP68 plugs	(Other MIL plugs are possible)
Case material	Brass	Nickel-plated
Max. allowed installation torque	30 Nm	Not to be exceeded under all circumstances
Dimensions	$\varnothing 32$ mm	2 nuts M32 x 1.5 for feed-through installation
Weight	approx. 250 g	Incl. 2 nuts

Dimensions [mm]

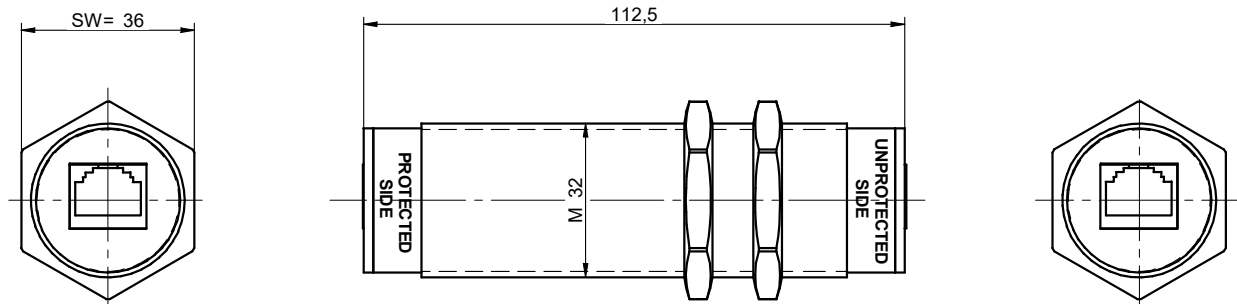

Design might be different depending on the plug

Installation Notes

- The USN-series EMP protector / filters shall be installed by electrically skilled personnel.
- The electrical wiring must be done according to local regulations.
- The max. values stated in this datasheet must not be exceeded under any circumstances.
- Do not exceed max. installation torque of 30 Nm as this can destroy the device.
- USN-series EMP protector / filters may be directly installed into the wall of a Faraday cage as feed-through device. For best performance the cabling should be shielded at least on the protected side.

General Recommendations for Protection Installation

- In order to achieve the full performance of a protection circuit the application of good - practice EMC design techniques is necessary for the whole system to be protected.
- For EMP - protection usually a shield as an electromagnetic barrier to protect a certain volume is necessary. This shield avoids coupling of radiated disturbances inside the protected volume. In addition to shielding all penetrating wires must be protected from conducted transient interferences by an appropriate POE (point of entry) protection.
- Use tested, high quality POE (point of entry) protection elements for all wires entering an electromagnetic shield and install these as feed - through devices, e.g. the Meteolabor® USS-1, USS-2, USP, CSP, USN or PLP series.

Ordering Information / Part Number

USN-80011 EMP Protector / Filter
10/100/1000 Mbit/s Ethernet / PoE



Caution

Maximum torque for installation screw shall not exceed 30 Nm

Contact

Meteolabor AG
Hofstrasse 92
CH-8620 Wetzikon
Switzerland

Tel: +41 44 934 40 40
E-Mail: info@meteolabor.ch
Internet: www.meteolabor.ch

© by Meteolabor AG
All rights reserved

Content may change without further notice 2023-07
USN-80011_e_V2023

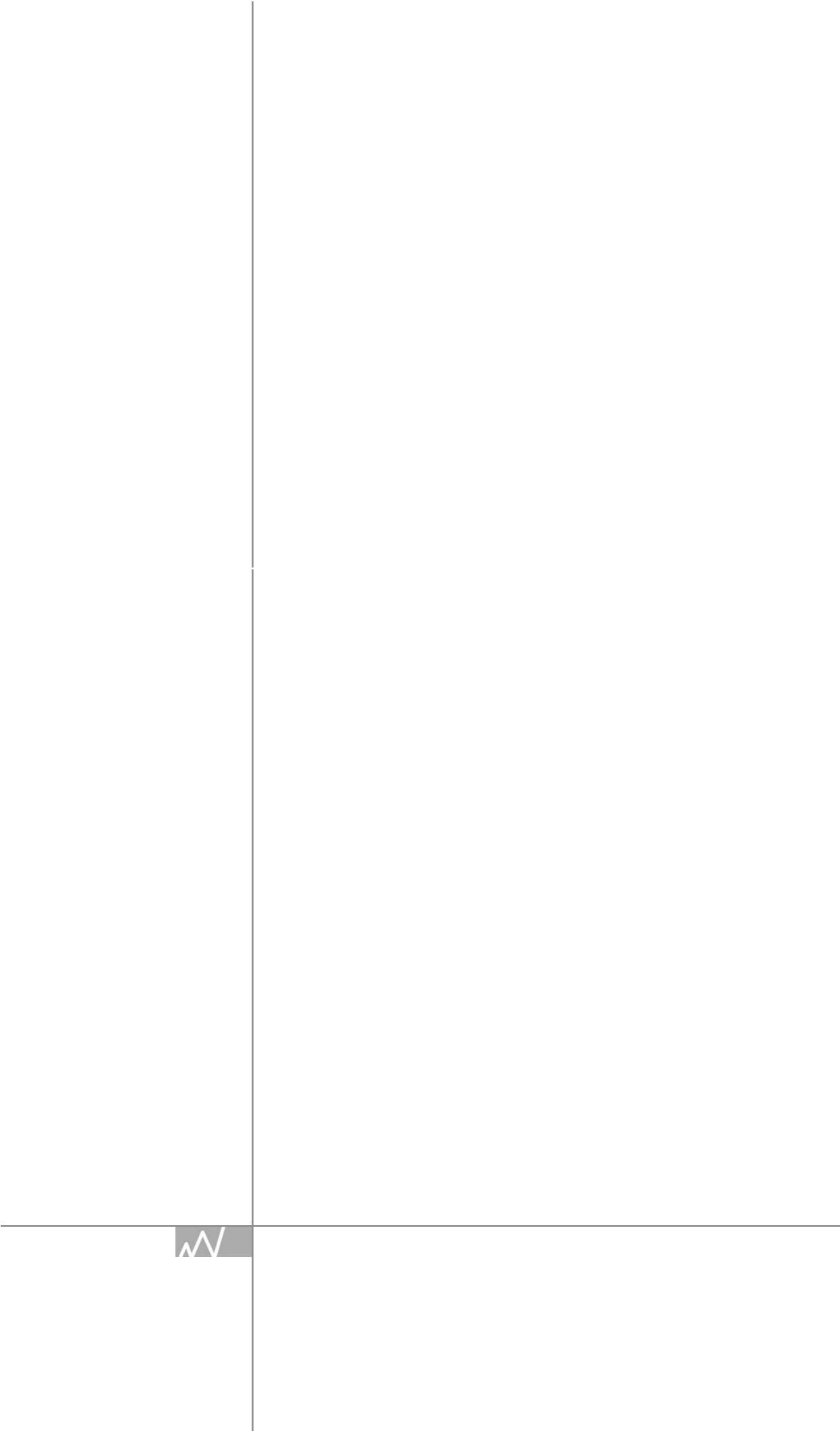



USP Series

Power Protection for Mobile or Fixed Applications



EMP Surge Protector/Filter 200/115V, 400Hz, 3L+N, 32A USP-26101, USP series

Overvoltage protector / filter for three phases and neutral 200/115 VAC, 400 Hz power supply lines, up to 32 A

Excellent protection of power supply lines against overvoltages of NEMP / HEMP and lightning (Class II + III) and also against RF interferences

Multi - stage design with common - mode and differential mode protection and integrated filter

HEMP threat - level tested according to MIL-STD-188-125-1-For details see chapter "3 User Information"

MIL-847 series connector sockets



The Meteolabor USP-26101 surge protector / filter is specially designed for overvoltage protection of power supply lines plus additionally contains an integrated filter for the attenuation of common and differential mode interferences.

The capability to handle high surge currents (up to 40 kA per conductor) ensures best protection against very fast transient overvoltages as they can be generated by NEMP / HEMP, lightning or switching.

Because of their low leakage current USP series protectors are ideally suited for mobile / portable systems and applications.

Applications

Surge protector / filter elements of the USP - series are optimized to protect sensitive units and systems against the effects of overvoltages and fast transients.

USP elements are specially suited to be used in sensitive and mission - critical defence systems (command and control systems, communication, IT installations etc.), in security installations, telecommunication equipment etc..

The universal mechanical design of the USP - series offers various ways of mounting the unit as a feed-through component in a Faraday cage. No matter if this is a fixed installation (building, underground shelter) or a mobile container or vehicle.

Technical Data USP-26101

Nominal operating voltage U_N	200 / 115 V AC	400 Hz
Max. operating voltage U_c	225 / 125 V AC	400 Hz
Nominal current I_N	32 A	RMS, at T_{amb} 45°C
Surge current nominal I_n	25 kA	multiple, L / N → PE, shape 8 / 20 μ s, T_{amb} 40°C
Max surge current I_{max}	40 kA	min one strike, L / N → PE, shape 8 / 20 μ s, T_{amb} 40°C
Max. differential surge current	20 kA	min one strike, L / N → PE, shape 8 / 20 μ s, T_{amb} 40°C
Residual voltage	< 2 kV	L → PE, shape 8 / 20 μ s, 25 kA
Residual voltage differential	< 1 kV	L → N, shape 8 / 20 μ s, 2 kA, IEC 61000-4-5
AC earth leakage current	< 3.5 mA	L → PE at U_N , 400 Hz (IEC 60950)
DC resistance	typ. <10 m Ω	per line, T_{amb} 25°C
Connector socket unprotected side	847-58-A1-00-N-302	male
Connector socket protected side	847-58-A5-00-N-302	female
Operating temperature range	- 40°C / + 85°C	Current to be derated above 65°C
Case material		Passivated aluminium
Dimensions	258 x111 x 71 mm	major dimensions (details see drawing on rear side)
Color	RAL 9005 (matt black)	Contact surfaces on fixing brackets are blank (stainless steel)
Weight	Approx. 4.8 kg	



EMP Surge Protector / Filter 230 V single phase, 10 A USP-34001, USP series

Overvoltage protector / filter for single phase 230 VAC, 50 / 60 Hz power supply lines, up to 10 A

Excellent protection of power supply lines against NEMP / HEMP and lightning overvoltages and also against RF interferences

Multi-stage design with common-mode and differential protection and integrated filter

Low leakage current (< 0.75 mA)

Threat-level tested against HEMP according to MIL-STD-188-125. For details see chapter "3 User Information"



Product

The Meteolabor USP-34001 surge protector / filter is specially designed for overvoltage protection of power supply lines plus additionally contains an integrated filter for the attenuation of common and differential mode interferences.

The capability to handle high surge currents (up to 40 kA per conductor) ensures best protection against very fast transient overvoltages as they can be generated by NEMP / HEMP, lightning or switching.

Because of their very low leakage current USP series protectors are also suited for mobile/portable applications.

A cable is integrated into the device on the unprotected side. On the protected side there is a spring clamp terminal block, which permits easy installation of interconnecting cable. A cable gland is integrated into the cover of the terminal block compartment.

Applications

Surge protector / filter elements of the USP series are optimized to protect sensitive units and systems against the effects of overvoltages and fast transients.

USP elements are specially suited to be used in sensitive and mission-critical defence systems (command and control systems, communication, IT installations aso.), in security installations, telecommunication equipment etc. The USP-series has been successfully used in many projects, where EMP-tests according to RS105 or similar, were done.

The universal mechanical design of the USP series offers various ways of mounting the unit as a feed-through component in a Faraday cage. No matter if this is a fixed installation (building, underground shelter) or a mobile container or vehicle.

Technical Data USP-34001

Nominal operating voltage U_N	230 V AC	50 / 60 Hz
Max. operating voltage U_c	255 V AC	50 / 60 Hz
Nominal current I_N	10 A	RMS, at T_{amb} 45°C
Surge current nominal I_n	25 kA	multiple, L / N → PE, shape 8 / 20 μ s, T_{amb} 40°C
Max surge current I_{max}	40 kA	min one strike, L / N → PE, shape 8 / 20 μ s, T_{amb} 40°C
Max. differential surge current	20 kA	min one strike, L / N → PE, shape 8 / 20 μ s, T_{amb} 40°C
Residual voltage	< 2,1 kV	L → PE, shape 8 / 20 μ s, 25 kA
Residual voltage differential	< 1 kV	L → N, shape 8 / 20 μ s, 2 kA, IEC 61000-4-5
AC earth leakage current	< 0.75 mA	L → PE at U_N , 50 Hz (IEC 60950)
DC resistance	typ. 11 m Ω	per line, T_{amb} 25°C
Connection unprotected side	cable, integrated	RADOX grey, 1.5 m, 3 x 1.5 mm ²
Connection protected side	terminal, spring clamp	max. 2.5 mm ² , cover plate with integrated cable gland
Case material		Passivated aluminium
Operating temperature range	- 40 °C / + 85 °C	
Dimensions	275 x 73 x 65 mm	major dimensions (details see drawing on rear side)
Weight	ca. 2.1 kg	



Dimensions

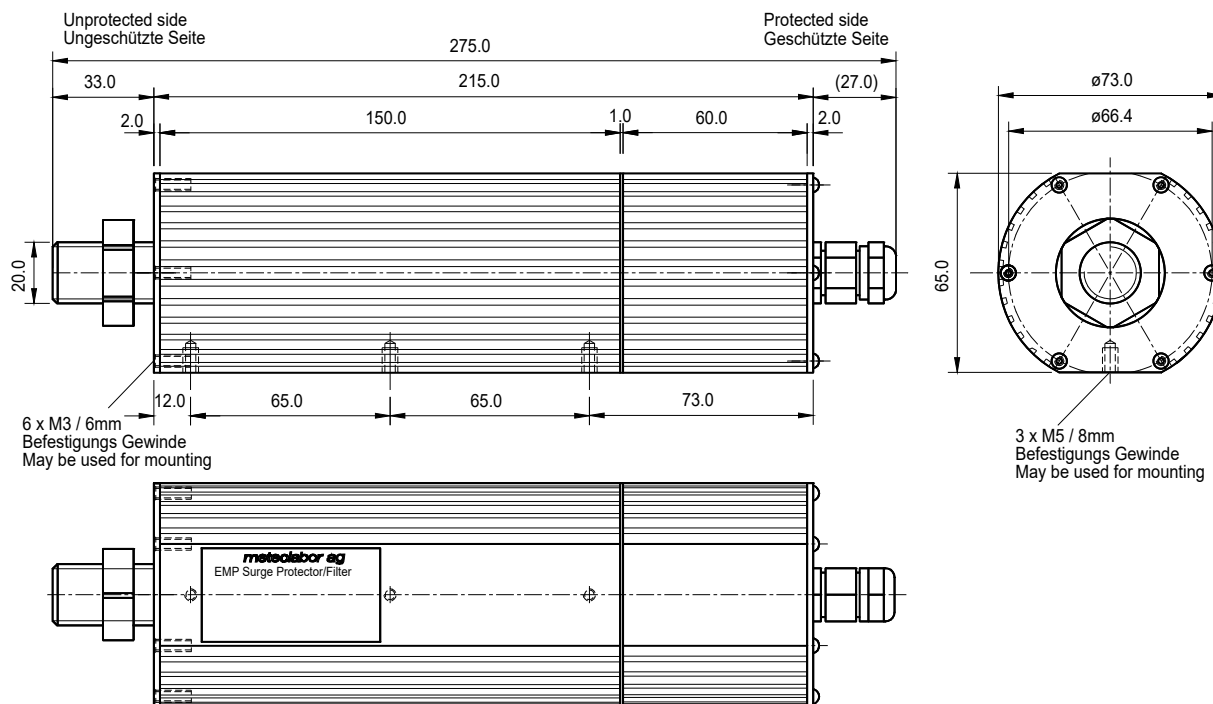

Installation Instructions

- The USP surge protector / filter has to be installed by electrically skilled personnel only.
- The electrical wiring of the unit has to be done according to the national standards and safety regulations.
- Always install Ground / Protective Earth first.
- From the USP surge protector / filter case a secure, low impedance connection to earth has to be made to ensure sufficient flow of discharge surge currents.
- Use a screwdriver for opening the spring clamp (WAGO CAGE CLAMP®) to insert or remove wire as shown on picture below.

Safety Notes

- Before opening the cover plate of the terminal area make sure that power is switched off.
- The unit does not contain any serviceable parts. Do not attempt to open the device, only the cover plate of the terminal area is allowed to be opened temporarily in order to install the cables. Close before switching on.
- After an overvoltage event causing visible damages in the protected or unprotected area, the protector/filter unit has to be tested or replaced.

Electrical Connection

Unprotected side:

Cable
Brown: Line / (L)
Blue: Neutral / (N)
Yellow / Green: PE
(Protective Earth / Ground / Case)

Protected side:

WAGO CageClamp®
Grey: Line / (L)
Blue: Neutral / (N)
Yellow / Green: PE
(Protective Earth / Ground / Case)

Protected Side, cover with cable gland removed

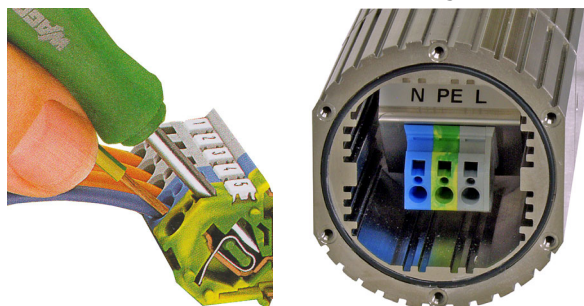

Ordering Information

Part-Nr.: **USP-34001**
Type-Nr.: USP-LNPE-230V-10A-CT001-AA

Contact

Meteolabor AG
Hofstrasse 92
CH-8620 Wetzikon
Switzerland

Tel: +41 44 934 40 40
E-Mail: info@meteolabor.ch
Internet: www.meteolabor.ch

© by Meteolabor AG
All rights reserved
Content may change without further notice 2023-07
USP-34001 _e_V2023



EMP Surge Protector / Filter 230 V single phase, 16 A USP-35001, USP series

**Overvoltage protector / filter for single phase
230 VAC, 50 / 60 Hz power supply lines, up to 16 A**

**Excellent protection of power supply lines against
NEMP / HEMP and lightning overvoltages and also
against RF interferences**

**Multi-stage design with common-mode and
differential protection and integrated filter**

Low leakage current (< 0.75 mA)

**Threat-level tested against HEMP according to
MIL-STD-188-125. For details see chapter "3 User
Information"**



Product

The Meteolabor USP-35001 surge protector / filter is specially designed for overvoltage protection of power supply lines plus additionally contains an integrated filter for the attenuation of common and differential mode interferences.

The capability to handle high surge currents (up to 40 kA per conductor) ensures best protection against very fast transient overvoltages as they can be generated by NEMP / HEMP, lightning or switching.

Because of their very low leakage current USP series protectors are also suited for mobile/portable applications.

A cable is integrated into the device on the unprotected side. On the protected side there is a spring clamp terminal block, which permits easy installation of interconnecting cable. A cable gland is integrated into the cover of the terminal block compartment.

Applications

Surge protector / filter elements of the USP series are optimized to protect sensitive units and systems against the effects of overvoltages and fast transients.

USP elements are specially suited to be used in sensitive and mission-critical defence systems (command and control systems, communication, IT installations aso.), in security installations, telecommunication equipment etc. The USP-series has been successfully used in many projects, where EMP-tests according to RS105 or similar, were done.

The universal mechanical design of the USP series offers various ways of mounting the unit as a feed-through component in a Faraday cage. No matter if this is a fixed installation (building, underground shelter) or a mobile container or vehicle.

Technical Data USP-35001

Nominal operating voltage U_N	230 V AC	50 / 60 Hz
Max. operating voltage U_c	255 V AC	50 / 60 Hz
Nominal current I_N	16 A	RMS, at T_{amb} 45°C
Surge current nominal I_n	25 kA	multiple, L / N → PE, shape 8 / 20 μ s, T_{amb} 40°C
Max surge current I_{max}	40 kA	min one strike, L / N → PE, shape 8 / 20 μ s, T_{amb} 40°C
Max. differential surge current	20 kA	min one strike, L / N → PE, shape 8 / 20 μ s, T_{amb} 40°C
Residual voltage	< 2,1 kV	L → PE, shape 8 / 20 μ s, 25 kA
Residual voltage differential	< 1 kV	L → N, shape 8 / 20 μ s, 2 kA, IEC 61000-4-5
AC earth leakage current	< 0.75 mA	L → PE at U_N , 50 Hz (IEC 60950)
DC resistance	typ. 11 m Ω	per line, T_{amb} 25°C
Connection unprotected side	cable, integrated	Purwil grey, 1.5 m, 3 x 1.5 mm ²
Connection protected side	terminal, spring clamp	max. 2.5 mm ² , cover plate with integrated cable gland
Case material		Passivated aluminium
Operating temperature range	- 40 °C / + 85 °C	
Dimensions	275 x 73 x 65 mm	major dimensions (details see drawing on rear side)
Weight	ca. 2.1 kg	

Dimensions

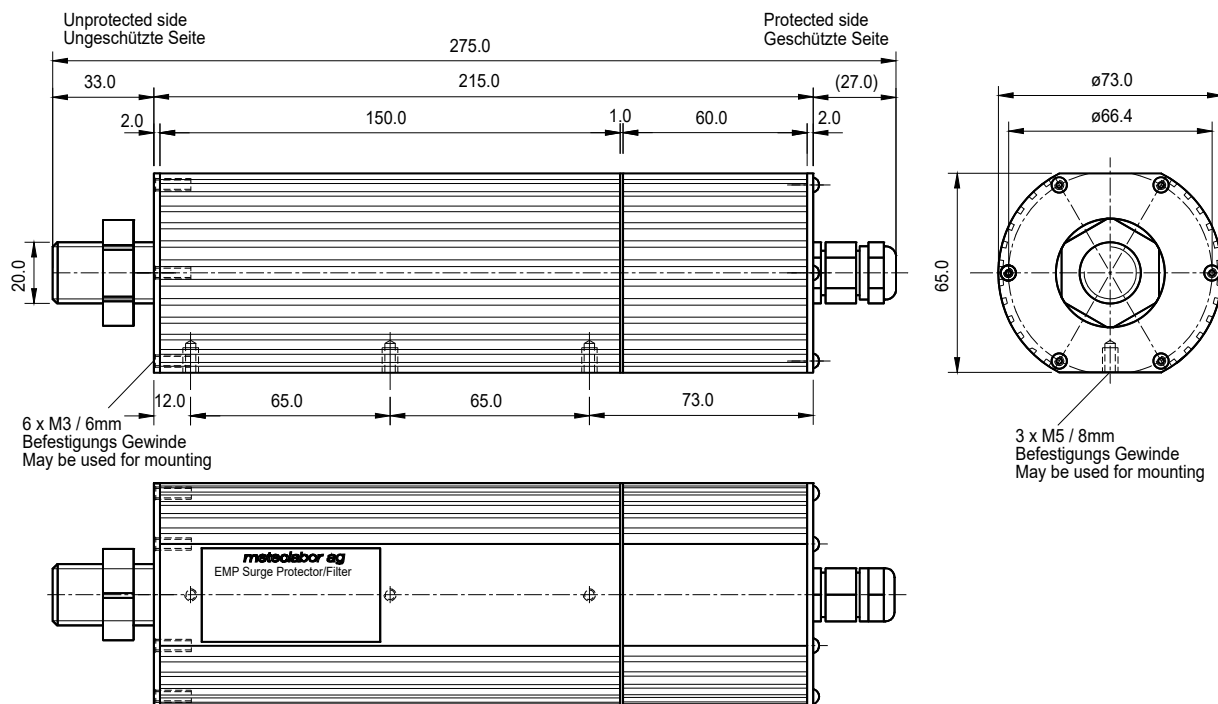

Installation Instructions

- The USP surge protector / filter has to be installed by electrically skilled personnel only.
- The electrical wiring of the unit has to be done according to the national standards and safety regulations.
- Always install Ground / Protective Earth first.
- From the USP surge protector / filter case a secure, low impedance connection to earth has to be made to ensure sufficient flow of discharge surge currents.
- Use a screwdriver for opening the spring clamp (WAGO CAGE CLAMP®) to insert or remove wire as shown on picture below.

Safety Notes

- Before opening the cover plate of the terminal area make sure that power is switched off.
- The unit does not contain any serviceable parts. Do not attempt to open the device, only the cover plate of the terminal area is allowed to be opened temporarily in order to install the cables. Close before switching on.
- After an overvoltage event causing visible damages in the protected or unprotected area, the protector/filter unit has to be tested or replaced.

Electrical Connection

Unprotected side:

Cable
 Brown: Line / (L)
 Blue: Neutral / (N)
 Yellow / Green: PE
 (Protective Earth / Ground / Case)

Protected side:

WAGO CageClamp®
 Grey: Line / (L)
 Blue: Neutral / (N)
 Yellow / Green: PE
 (Protective Earth / Ground / Case)

Protected Side, cover with cable gland removed

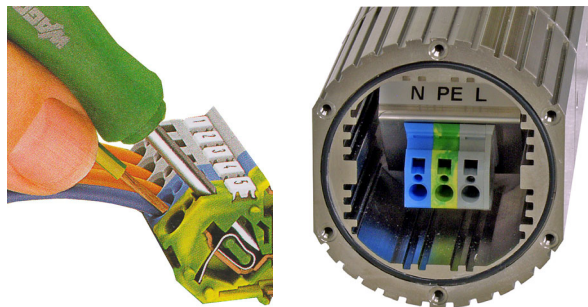

Ordering Information

Part-Nr.: **USP-35001**

Type-Nr.: USP-LNPE-230V-16A-CT001-AA

Contact

Meteolabor AG
 Hofstrasse 92
 CH-8620 Wetzikon
 Switzerland

Tel: +41 44 934 40 40
 E-Mail: info@meteolabor.ch
 Internet: www.meteolabor.ch

© by Meteolabor AG
 All rights reserved

Content may change without further notice 2023-07
 USP-35001 _e_V2023



EMP Surge Protector / Filter 230 V single phase, 16 A USP-35002, USP series

**Overvoltage protector / filter for single phase
230 VAC, 50 / 60 Hz power supply lines, up to 16 A**

**Excellent protection of power supply lines against
NEMP / HEMP and lightning overvoltages and also
against RF interferences**

**Multi-stage design with common-mode and
differential protection and integrated filter**

Low leakage current (< 0.75 mA)

**Threat-level tested against HEMP according to
MIL-STD-188-125. For details see chapter "3 User
Information"**



Product

The Meteolabor USP-35002 surge protector / filter is specially designed for overvoltage protection of power supply lines plus additionally contains an integrated filter for the attenuation of common and differential mode interferences.

The capability to handle high surge currents (up to 40 kA per conductor) ensures best protection against very fast transient overvoltages as they can be generated by NEMP / HEMP, lightning or switching.

Because of their very low leakage current USP series protectors are also suited for mobile/portable applications.

A cable is integrated into the device on the unprotected side. On the protected side there is a spring clamp terminal block, which permits easy installation of interconnecting cable. A cable gland is integrated into the cover of the terminal block compartment.

Technical Data USP-35002

Nominal operating voltage U_N	230 V AC	50 / 60 Hz
Max. operating voltage U_c	255 V AC	50 / 60 Hz
Nominal current I_N	16 A	RMS, at T_{amb} 45°C
Surge current nominal I_n	25 kA	multiple, L / N → PE, shape 8 / 20 μ s, T_{amb} 40°C
Max surge current I_{max}	40 kA	min one strike, L / N → PE, shape 8 / 20 μ s, T_{amb} 40°C
Max. differential surge current	20 kA	min one strike, L / N → PE, shape 8 / 20 μ s, T_{amb} 40°C
Residual voltage	< 2,1 kV	L → PE, shape 8 / 20 μ s, 25 kA
Residual voltage differential	< 1 kV	L → N, shape 8 / 20 μ s, 2 kA, IEC 61000-4-5
AC earth leakage current	< 0.75 mA	L → PE at U_N , 50 Hz (IEC 60950)
DC resistance	typ. 11 m Ω	per line, T_{amb} 25°C
Connection unprotected side	cable, integrated	grey, 1.5 m, 3 x 1.5 mm ²
Connection protected side	terminal, spring clamp	max. 2.5 mm ² , cover plate with integrated cable gland
Case material		Passivated aluminium
Operating temperature range	- 40 °C / + 85 °C	
Dimensions	255 x 73 x 65 mm	major dimensions (details see drawing on rear side)
Weight	ca. 2.1 kg	

Applications

Surge protector / filter elements of the USP series are optimized to protect sensitive units and systems against the effects of overvoltages and fast transients.

USP elements are specially suited to be used in sensitive and mission-critical defence systems (command and control systems, communication, IT installations aso.), in security installations, telecommunication equipment etc. The USP-series has been successfully used in many projects, where EMP-tests according to RS105 or similar, were done.

The universal mechanical design of the USP series offers various ways of mounting the unit as a feed-through component in a Faraday cage. No matter if this is a fixed installation (building, underground shelter) or a mobile container or vehicle.



Dimensions

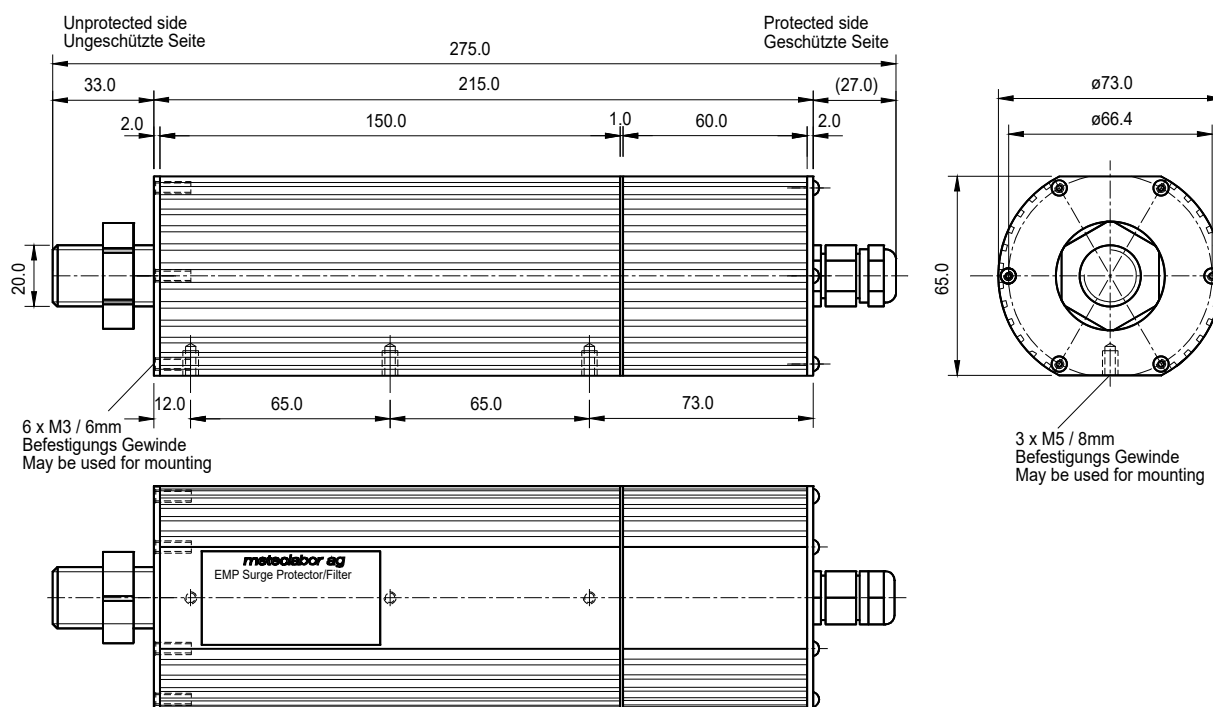

Installation Instructions

- The USP surge protector / filter has to be installed by electrically skilled personnel only.
- The electrical wiring of the unit has to be done according to the national standards and safety regulations.
- Always install Ground / Protective Earth first.
- From the USP surge protector / filter case a secure, low impedance connection to earth has to be made to ensure sufficient flow of discharge surge currents.
- Use a screwdriver for opening the spring clamp (WAGO CAGE CLAMP®) to insert or remove wire as shown on picture below.

Safety Notes

- Before opening the cover plate of the terminal area make sure that power is switched off.
- The unit does not contain any serviceable parts. Do not attempt to open the device, only the cover plate of the terminal area is allowed to be opened temporarily in order to install the cables. Close before switching on.
- After an overvoltage event causing visible damages in the protected or unprotected area, the protector/filter unit has to be tested or replaced.

Electrical Connection

Unprotected side:

Cable
 Brown: Line / (L)
 Blue: Neutral / (N)
 Yellow / Green: PE
 (Protective Earth / Ground / Case)

Protected side:

WAGO CageClamp®
 Grey: Line / (L)
 Blue: Neutral / (N)
 Yellow / Green: PE
 (Protective Earth / Ground / Case)

Protected Side, cover with cable gland removed

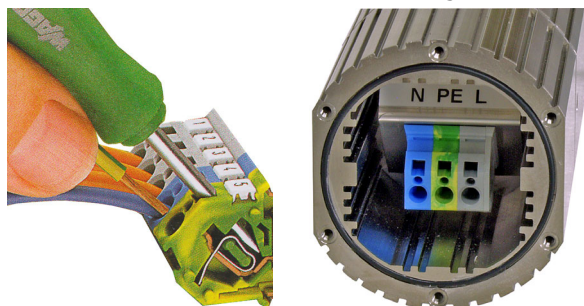

Ordering Information

Part-Nr.: **USP-35002**
 Type-Nr.: USP-LNPE-230V-16A-CC002-AA

Contact

Meteolabor AG
 Hofstrasse 92
 CH-8620 Wetzikon
 Switzerland

Tel: +41 44 934 40 40
 E-Mail: info@meteolabor.ch
 Internet: www.meteolabor.ch

© by Meteolabor AG
 All rights reserved

Content may change without further notice 2023-07
 USP-35002_e_V2023

EMP Surge Protector / Filter 230 V single phase, 16 A USP-35004, USP series

Overvoltage protector / filter for single phase 230 VAC, 50 / 60 Hz power supply lines, up to 16 A

Excellent protection of power supply lines against NEMP / HEMP and lightning overvoltages and also against RF interferences

Multi-stage design with common-mode and differential protection and integrated filter

Low leakage current (< 0.75 mA)

Threat-level tested against HEMP according to MIL-STD-188-125. For details see chapter "3 User Information"

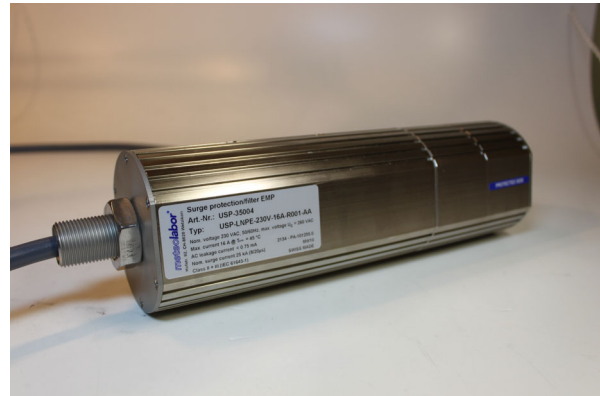

Product

The Meteolabor USP-35004 surge protector / filter is specially designed for overvoltage protection of power supply lines plus additionally contains an integrated filter for the attenuation of common and differential mode interferences.

The capability to handle high surge currents (up to 40 kA per conductor) ensures best protection against very fast transient overvoltages as they can be generated by NEMP / HEMP, lightning or switching.

Because of their very low leakage current USP series protectors are also suited for mobile/portable applications.

A cable is integrated into the device on the unprotected side. On the protected side there leads another cable at a right angle to the protected side.

Applications

Surge protector filter elements of the USP series are optimized to protect sensitive units and systems against the effects of overvoltages and fast transients.

USP elements are specially suited to be used in sensitive and mission-critical defence systems (command and control systems, communication, IT installations aso.), in security installations, telecommunication equipment etc. The USP-series has been successfully used in many projects, where EMP-tests according to RS105 or similar, were done.

The universal mechanical design of the USP series offers various ways of mounting the unit as a feed-through component in a Faraday cage. No matter if this is a fixed installation (building, underground shelter) or a mobile container or vehicle.

Technical Data USP-35004

Nominal operating voltage U_N	230 V AC	50 / 60 Hz
Max. operating voltage U_c	255 V AC	50 / 60 Hz
Nominal current I_N	16 A	RMS, at T_{amb} 45°C
Surge current nominal I_n	25 kA	multiple, L / N → PE, shape 8 / 20 μs, T_{amb} 40°C
Max surge current I_{max}	40 kA	min one strike, L / N → PE, shape 8 / 20 μs, T_{amb} 40°C
Max. differential surge current	20 kA	min one strike, L / N → PE, shape 8 / 20 μs, T_{amb} 40°C
Residual voltage	< 2,1 kV	L → PE, shape 8 / 20 μs, 25 kA
Residual voltage differential	< 1 kV	L → N, shape 8 / 20 μs, 2 kA, IEC 61000-4-5
AC earth leakage current	< 0.75 mA	L → PE at U_N , 50 Hz (IEC 60950)
DC resistance	typ. 11 mΩ	per line, T_{amb} 25°C
Connection unprotected side	cable, integrated	grey, 1.5 m, 3 x 1.5 mm ²
Connection protected side	Cable, integrated	grey, 5 m, 3 x 1.5 mm ²
Case material		Passivated aluminium
Operating temperature range	- 40 °C / + 85 °C	
Dimensions	268 x 73 x 65 mm	
Weight	ca. 2.2 kg	

Dimensions

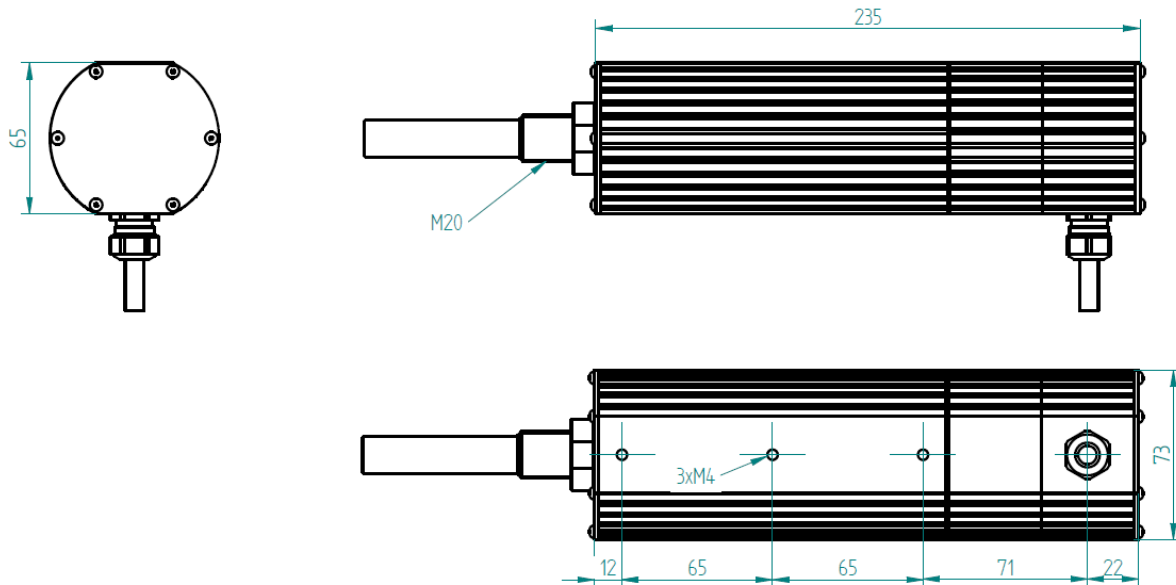

Installation Instructions

- The USP surge protector / filter has to be installed by electrically skilled personnel only.
- The electrical wiring of the unit has to be done according to the national standards and safety regulations.
- Always install Ground / Protective Earth first.
- From the USP surge protector / filter case a secure, low impedance connection to earth has to be made to ensure sufficient flow of discharge surge currents.
- Use a screwdriver for opening the spring clamp (WAGO CAGE CLAMP®) to insert or remove wire as shown on picture below.
- The cable entry into the Faraday cage must have a diameter of 22 mm.
- The protector has to be installed in the unprotected side, the cable entry into the Faraday cage leads to the protected area.

Electrical Connection

Unprotected side:

Cable
 Brown: Line / (L)
 Blue: Neutral / (N)
 Yellow / Green: PE
 (Protective Earth / Ground / Case)

Protected side:

Cable
 Brown: Line / (L)
 Blue: Neutral / (N)
 Yellow / Green: PE
 (Protective Earth / Ground / Case)

Safety Notes

- Before opening the cover plate of the terminal area make sure that power is switched off.
- The unit does not contain any serviceable parts. Do not attempt to open the device, only the cover plate of the terminal area is allowed to be opened temporarily in order to install the cables. Close before switching on.
- After an overvoltage event causing visible damages in the protected or unprotected area, the protector/filter unit has to be tested or replaced.

Ordering Information

Part-Nr.: **USP-35004**

Type-Nr.: USP-LNPE-230V-6A-CT001-AA

Contact

Meteolabor AG
 Hofstrasse 92
 CH-8620 Wetzikon
 Switzerland

Tel: +41 44 934 40 40
 E-Mail: info@meteolabor.ch
 Internet: www.meteolabor.ch

© by Meteolabor AG
 All rights reserved

Content may change without further notice 2023-07
 USP-35004_e_V2023



EMP Surge Protector / Filter 230 V single phase, 16 A USP-35101

**Overvoltage protector / filter for single phase
230 VAC, 50 / 60 Hz power supply lines, up to 16 A**

**Excellent protection of power supply lines against
NEMP / HEMP and lightning overvoltages and also
against RF interferences**

**Combined multi - stage design with common -
mode and differential protection and integrated
filter**

**HEMP threat - level tested according to
MIL-STD-188-125-1. For details see chapter "3 User
Information"**

Low leakage current (< 0.75 mA)



The Meteolabor USP-35101 surge protector / filter is specially designed for overvoltage protection of power supply lines plus additionally contains an integrated filter for the attenuation of common and differential mode interferences.

The capability to handle high surge currents (up to 40 kA per conductor) ensures best protection against very fast transient overvoltages as they can be generated by NEMP / HEMP, lightning or switching.

Because of their very low leakage current USP - series protectors are also suited for mobile/portable applications.

A cable is integrated into the device on the unprotected side. On the protected side there is a spring clamp terminal block, which permits easy installation of interconnecting cable. A cable gland is integrated into the cover of the terminal block compartment.

Applications

Surge protector / filter elements of the USP - series are optimized to protect sensitive units and systems against the effects of overvoltages and fast transients.

USP elements are specially suited to be used in sensitive and mission - critical defence systems (command and control systems, communication, IT installations aso.), in security installations, telecommunication equipment etc. The USP - series has been successfully used in many projects, where EMP - tests according to RS105 or similar, were done.

The universal mechanical design of the USP series offers various ways of mounting the unit as a feed - through component in a Faraday cage. No matter if this is a fixed installation (building, underground shelter) or a mobile container or vehicle. An electrically conducting gasket is included for this purpose.

Technical Data USP-35101

Nominal operating voltage U_N	230 V AC	50 / 60 Hz
Max. operating voltage U_c	255 V AC	50 / 60 Hz
Nominal current I_N	16 A	RMS, at T_{amb} 45°C
Surge current nominal I_n	25 kA	multiple, L / N → PE, shape 8 / 20 μ s, T_{amb} 40°C
Max surge current I_{max}	40 kA	minimum one strike, L / N → PE, shape 8 / 20 μ s, T_{amb} 40°C
Max. differential surge current	20 kA	minimum one strike, L / N → PE, shape 8 / 20 μ s, T_{amb} 40°C
Residual voltage	< 2,1 kV	L → PE, shape 8 / 20 μ s, 25 kA
Residual voltage differential	< 1 kV	L → N, shape 8 / 20 μ s, 2 kA, IEC 61000-4-5
AC earth leakage current	< 0.75 mA	L → PE at U_N , 50 Hz (IEC 60950)
DC resistance	typ. 11 m Ω	per line, T_{amb} 25°C
Connection unprotected side	cable, integrated	grey, 1.5 m, 3 x 1.5 mm ²
Connection protected side	cable, integrated	grey, 5.0 m, 3 x 1.5 mm ²
Operating temperature range	- 40°C / + 85°C	Current to be linearly derated above 45°C from I_N to 10A
Case materials		Passivated aluminium
Dimensions	255 x 73 x 65 mm	major dimensions (details see drawing on rear side)
Weight	ca. 2.1 kg	

Dimensions

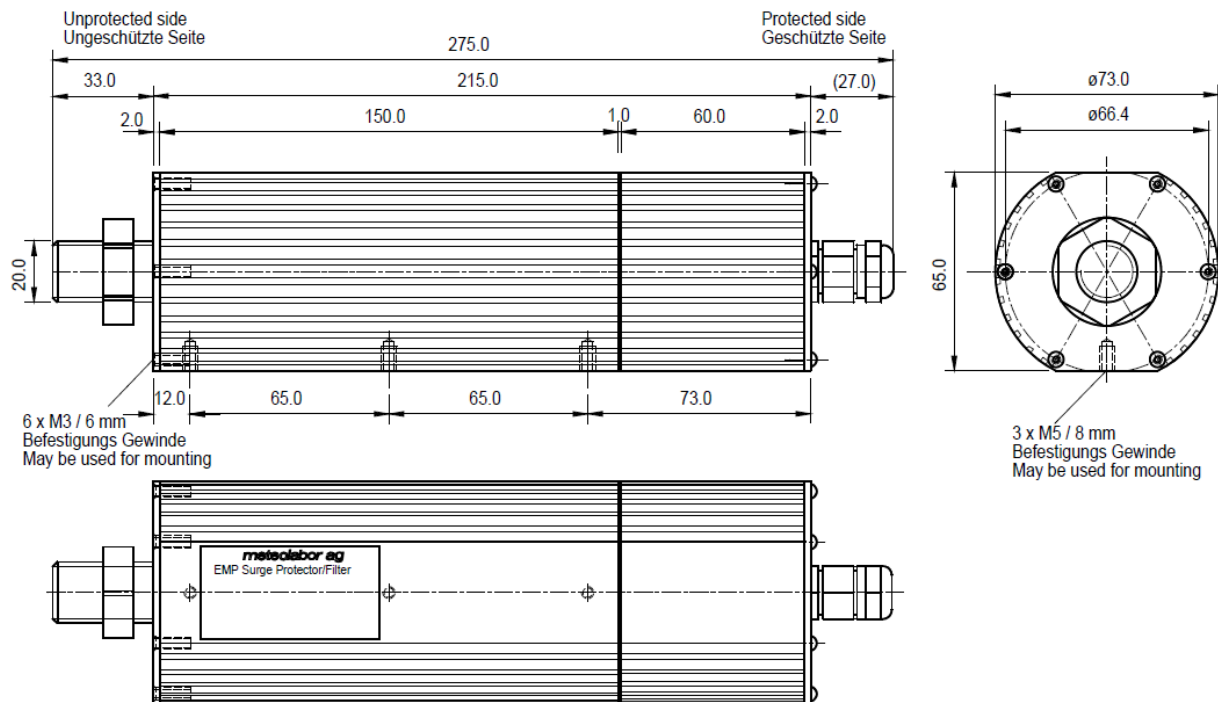

Installation Instructions

- The USP surge protector / filter has to be installed by electrically skilled personnel only.
- The electrical wiring of the unit has to be done according to the national standards and safety regulations.
- Always install Ground / Protective Earth first.
- From the USP surge protector / filter case (grounding bolt) a secure, low impedance connection to earth has to be made to ensure sufficient flow of discharge surge currents.
- Use a screwdriver for opening the spring clamp (WAGO CAGE CLAMP®) to insert or remove wire as shown on picture below.

Safety and Maintenance Notes

- Before opening the cover plate the terminal area make sure that power is switched off.
- The unit does not contain any serviceable parts. Do not attempt to open the device, only the cover plate of the terminal area is allowed to be opened temporarily in order to install the cables. Close before switching on..
- After a severe overvoltage event causing visible damages in the protected or unprotected area, the protector / filter unit has to be tested or replaced.

Electrical Connection

Unprotected side:

Cable
 Brown: Line / (L)
 Blue: Neutral / (N)
 Yellow / Green: PE
 (Protective Earth / Ground / Case)

Protected side:

Cable
 Brown: Line / (L)
 Blue: Neutral / (N)
 Yellow / Green: PE
 (Protective Earth / Ground / Case)

Ordering Information

Part-Nr.: **USP-35101**

Type-Nr.: USP-LNPE-230V-16A-CC101-AA

Contact

Meteolabor AG
 Hofstrasse 92
 CH-8620 Wetzikon
 Switzerland

Tel: +41 44 934 40 40
 E-Mail: info@meteolabor.ch
 Internet: www.meteolabor.ch

© by Meteolabor AG
 All rights reserved

Content may change without further notice 2023-07
 USP-35101_e_V2023



EMP Surge Protector / Filter 230 V single phase, 16 A USP-35102, USP Series

**Overvoltage protector / filter for single phase
230 VAC, 50 / 60 Hz power supply lines, up to 16 A**

**Excellent protection of power supply lines against
NEMP / HEMP and lightning overvoltages and also
against RF interferences**

**Combined multi - stage design with common -
mode and differential protection and integrated
filter**

**HEMP threat - level tested according to
MIL-STD-188-125-1. For details see chapter "3 User
Information"**

Low leakage current (< 0.75 mA)



The Meteolabor USP-35102 surge protector / filter is specially designed for overvoltage protection of power supply lines plus additionally contains an integrated filter for the attenuation of common and differential mode interferences.

The capability to handle high surge currents (up to 40 kA per conductor) ensures best protection against very fast transient overvoltages as they can be generated by NEMP / HEMP, lightning or switching.

Because of their very low leakage current USP - series protectors are also suited for mobile/portable applications.

USP-35102 version uses "PowerSafe" receptacles according to VG 96644 on both unprotected and protected sides. Pilot contact is not used in this version.

Applications

Surge protector / filter elements of the USP - series are optimized to protect sensitive units and systems against the effects of overvoltages and fast transients.

USP elements are specially suited to be used in sensitive and mission - critical defence systems (command and control systems, communication, IT installations aso.), in security installations, telecommunication equipment etc. The USP - series has been successfully used in many projects, where EMP - tests according to RS105 or similar, were done.

The universal mechanical design of the USP series offers various ways of mounting the unit as a feed - through component in a Faraday cage. No matter if this is a fixed installation (building, underground shelter) or a mobile container or vehicle.

Technical Data USP-35102

Nominal operating voltage U_N	230 V AC	50 / 60 Hz
Max. operating voltage U_c	255 V AC	50 / 60 Hz
Nominal current I_N	16 A	RMS, at T_{amb} 45°C
Surge current nominal I_n	25 kA	multiple, L / N → PE, shape 8 / 20 μ s, T_{amb} 40°C
Max surge current I_{max}	40 kA	minimum one strike, L / N → PE, shape 8 / 20 μ s, T_{amb} 40°C
Max. differential surge current	20 kA	minimum one strike, L / N → PE, shape 8 / 20 μ s, T_{amb} 40°C
Residual voltage	< 2,1 kV	L → PE, shape 8 / 20 μ s, 25 kA
Residual voltage differential	< 1 kV	L → N, shape 8 / 20 μ s, 2 kA, IEC 61000-4-5
AC earth leakage current	< 0.75 mA	L → PE at U_N , 50 Hz (IEC 60950)
DC resistance	typ. 11 m Ω	per line, T_{amb} 25°C
Connection unprotected side	terminal, spring clamp	Wire with end leeves 0.25-2.5 mm ² (without 0.08-4 mm ²)
Connection protected side	terminal, spring clamp	Wire with end leeves 0.25-2.5 mm ² (without 0.08-4 mm ²)
Operating temperature range	- 40°C / + 85°C	
Dimensions	330 x 73 x 65 mm	major dimensions (details see drawing on rear side)
Case material		Passivated aluminium
Weight	ca. 2.1 kg	



Dimensions

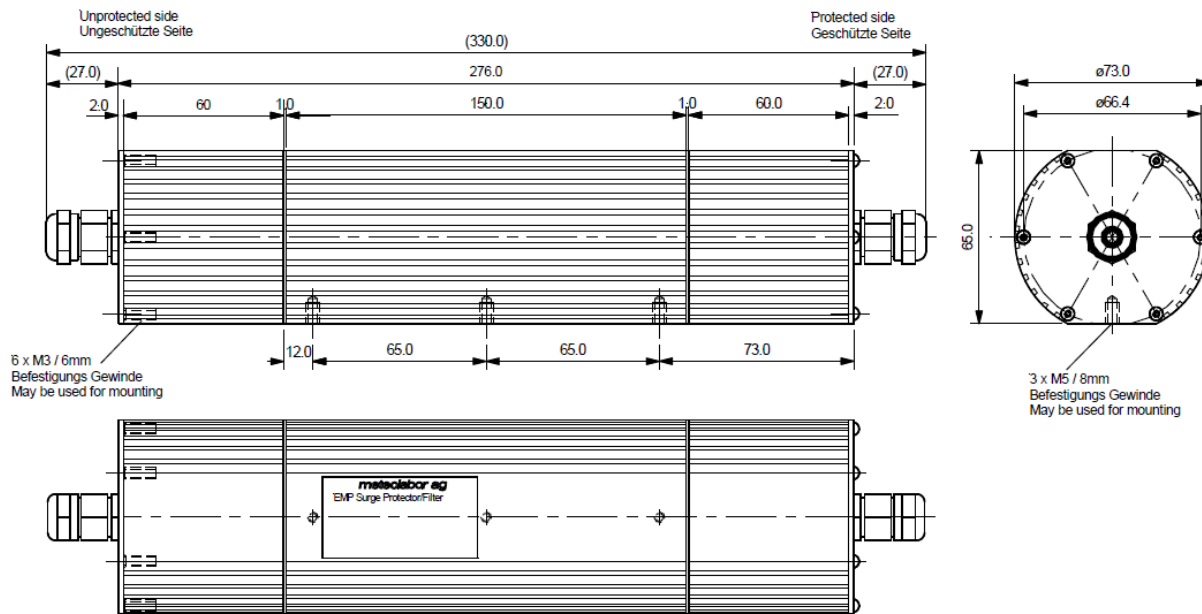

Installation Instructions

- The USP surge protector / filter has to be installed by electrically skilled personnel only.
- The electrical wiring of the unit has to be done according to the national standards and safety regulations.
- Always install Ground / Protective Earth first.
- From the USP surge protector / filter case (grounding bolt) a secure, low impedance connection to earth has to be made to ensure sufficient flow of discharge surge currents.
- Use a screwdriver for opening the spring clamp (WAGO CAGE CLAMP®) to insert or remove wire as shown on picture below.

Safety and Maintenance Notes

- Before opening the cover plate of the terminal area make sure that power is switched off.
- The unit does not contain any serviceable parts. Do not attempt to open the device, only the cover plate of the terminal area is allowed to be opened temporarily in order to install the cables. Close before switching on.
- After an overvoltage event causing visible damages in the protected or unprotected area, the protector / filter unit has to be tested or replaced

Electrical Connection

Unprotected side:

WAGO CageClamp®
 Grey: Line / (L)
 Blue: Neutral / (N)
 Yellow / Green: PE
 (Protective Earth / Ground / Case)

Protected side:

WAGO CageClamp®
 Grey: Line / (L)
 Blue: Neutral / (N)
 Yellow / Green: PE
 (Protective Earth / Ground / Case)

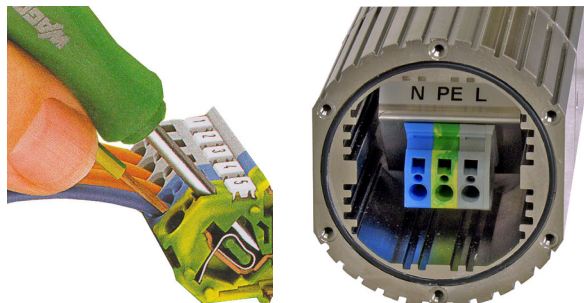

Ordering Information

Part-Nr.: **USP-35102**
 Type-Nr.: USP-LNPE-230V-16A-TT001-AA

Contact

Meteolabor AG
 Hofstrasse 92
 CH-8620 Wetzikon
 Switzerland

Tel: +41 44 934 40 40
 E-Mail: info@meteolabor.ch
 Internet: www.meteolabor.ch

© by Meteolabor AG
 All rights reserved
 Content may change without further notice 2023-07
 USP-35102_e_V2023

EMP Surge Protector / Filter 230 V single phase, 16 A USP-35105

Overvoltage protector / filter for single phase 230 VAC, 50 / 60 Hz power supply lines, up to 16 A

Excellent protection of power supply lines against NEMP / HEMP and lightning overvoltages and also against RF interferences

Combined multi - stage design with common - mode and differential protection and integrated filter

HEMP threat - level tested according to MIL-STD-188-125-1. For details see chapter "3 User Information"

Low leakage current (< 0.75 mA)



The Meteolabor USP-35105 surge protector / filter is specially designed for overvoltage protection of power supply lines plus additionally contains an integrated filter for the attenuation of common and differential mode interferences.

The capability to handle high surge currents (up to 40 kA per conductor) ensures best protection against very fast transient overvoltages as they can be generated by NEMP / HEMP, lightning or switching. Because of their very low leakage current USP - series protectors are also suited for mobile/portable applications.

A cable is integrated into the device on both, the unprotected and protected side.

Applications

Surge protector / filter elements of the USP - series are optimized to protect sensitive units and systems against the effects of overvoltages and fast transients.

USP elements are specially suited to be used in sensitive and mission - critical defence systems (command and control systems, communication, IT installations), in security installations, telecommunication equipment etc. The USP - series has been successfully used in many projects, where EMP - tests according to RS105 or similar, were done.

The universal mechanical design of the USP series offers various ways of mounting the unit as a feed - through component in a Faraday cage. No matter if this is a fixed installation (building, underground shelter) or a mobile container or vehicle. An electrically conducting gasket is included for this purpose.

Technical Data USP-35105

Nominal operating voltage U_N	230 V AC	50 / 60 Hz
Max. operating voltage U_c	255 V AC	50 / 60 Hz
Nominal current I_N	16 A	RMS, at T_{amb} 45°C
Surge current nominal I_n	25 kA	multiple, L / N → PE, shape 8 / 20 μs, T_{amb} 40°C
Max surge current I_{max}	40 kA	minimum one strike, L / N → PE, shape 8 / 20 μs, T_{amb} 40°C
Max. differential surge current	20 kA	minimum one strike, L / N → PE, shape 8 / 20 μs, T_{amb} 40°C
Residual voltage	< 2,1 kV	L → PE, shape 8 / 20 μs, 25 kA
Residual voltage differential	< 1 kV	L → N, shape 8 / 20 μs, 2 kA, IEC 61000-4-5
AC earth leakage current	< 0.75 mA	L → PE at U_N , 50 Hz (IEC 60950)
DC resistance	typ. 11 mΩ	per line, T_{amb} 25°C (320 mΩ with 25 m ÖLFLEX cable)
Connection unprotected side	cable, integrated	ÖLFLEX 540 CP 10 m, 3 x 1.5 mm ² shielded
Connection protected side	cable, integrated	ÖLFLEX 540 CP 15 m, 3 x 1.5 mm ² shielded
Operating temperature range	- 40°C / + 85°C	Current to be linearly derated above 45°C from I_N to 10A
Case materials	Case	Passivated aluminium
	Strain relief	Stainless steel
Dimensions	281 x 73 x 65 mm	major dimensions (details see drawing on rear side)
Filling material	Epoxy	encapsulated on both sides with epoxy resin
Weight	2.1 kg / 6.2 kg	(without / with cables)

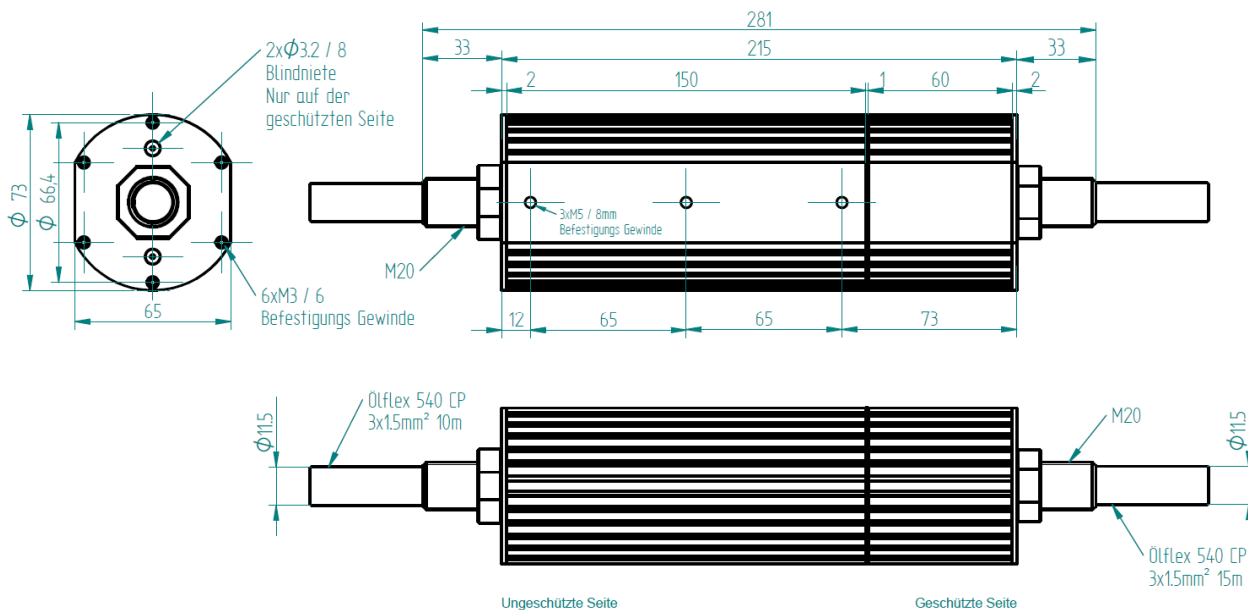

Dimensions

Installation Instructions

- The USP surge protector / filter has to be installed by electrically skilled personnel only.
- The electrical wiring of the unit has to be done according to the national standards and safety regulations.
- Always install Ground / Protective Earth first.
- From the USP surge protector / filter case a secure, low impedance connection to earth has to be made to ensure sufficient flow of discharge surge currents
- The shield of the two Ölflex cables is internally connected to the ground of the USP-35105. The shield should not be additionally connected on the connection side of both Ölflex cables.

Electrical Connection

Unprotected side:

ÖLFLEX 540 CP 10 m
 Brown: Line / (L)
 Blue: Neutral / (N)
 Yellow / Green: PE
 (Protective Earth / Ground / Case)

Ordering Information

Part-Nr.: **USP-35105**

Type-Nr.: USP-LNPE-230V-16A-CC105-BA

Safety and Maintenance Notes

- Before opening the cover plate the terminal area make sure that power is switched off.
- The unit does not contain any serviceable parts. Do not attempt to open the device, only the cover plate of the terminal area is allowed to be opened temporarily in order to install the cables. Close before switching on..
- After a severe overvoltage event causing visible damages in the protected or unprotected area, the protector / filter unit has to be tested or replaced.

Protected side:

ÖLFLEX 540 CP 15 m
 Brown: Line / (L)
 Blue: Neutral / (N)
 Yellow / Green: PE
 (Protective Earth / Ground / Case)

Contact

Meteolabor AG
 Hofstrasse 92
 CH-8620 Wetzikon
 Switzerland

Tel: +41 44 934 40 40
 E-Mail: info@meteolabor.ch
 Internet: www.meteolabor.ch

© by Meteolabor AG
 All rights reserved

Content may change without further notice 2023-07
 USP-35105_e_V2023



EMP Surge Protector / Filter 230 V, 50 / 60 Hz, L + N + PE, 63 A USP-38101, USP series

Overvoltage protector / filter for single phase and neutral 230 VAC, 50 / 60 Hz power supply lines, up to 63 A

Excellent protection of power supply lines against overvoltages of NEMP / HEMP and lightning (Class II + III) and also against RF interferences

Multi - stage design with common - mode and differential mode protection and integrated filter

HEMP threat - level tested according to MIL-STD-188-125-1. For details see chapter "3 User Information"



Product Description

The Meteolabor USP-38101 surge protector / filter is specially designed for overvoltage protection of power supply lines plus additionally contains an integrated filter for the attenuation of common and differential mode interferences.

The capability to handle high surge currents (up to 40 kA per conductor) ensures best protection against very fast transient overvoltages as they can be generated by NEMP / HEMP, lightning or switching.

Because of their low leakage current USP - series protectors are ideally suited for mobile/portable systems and applications.

Applications

Surge protector / filter elements of the USP - series are optimized to protect sensitive units and systems against the effects of overvoltages and fast transients.

USP elements are specially suited to be used in sensitive and mission - critical defence systems (e.g. command and control systems, communication, IT installations), in security installations, telecommunication equipment etc. The USP series has been successfully used in many projects, where EMP - tests according to RS105 or similar, were done.

The universal mechanical design of the USP - series offers various ways of mounting the unit as a feed - through component in a Faraday cage. No matter if this is a fixed installation (building, underground shelter) or a mobile container or vehicle.

Technical Data USP-38101

Nominal operating voltage U_N	230 V AC	50 / 60 Hz
Max. operating voltage U_C	275 V AC	50 / 60 Hz
Nominal current I_N	63 A	RMS, at T_{amb} 45°C
Surge current nominal I_n	25 kA	multiple, L / N → PE, shape 8 / 20 μ s, T_{amb} 40°C
Max surge current I_{max}	40 kA	min one strike, L / N → PE, shape 8 / 20 μ s, T_{amb} 40°C
Max. differential surge current	20 kA	min one strike, L / N → PE, shape 8 / 20 μ s, T_{amb} 40°C
Residual voltage	< 2 kV	L → PE, shape 8 / 20 μ s, 25 kA
Residual voltage differential	< 1 kV	L → N, shape 8 / 20 μ s, 2 kA, IEC 61000-4-5
AC earth leakage current	< 3.5 mA	L → PE at U_N , 50 Hz (IEC 60950)
DC resistance	< 15 m Ω	typical, per line, T_{amb} 25°C, incl. 2x 1.5 m cables
Connection unprotected side	1.5 m round cable PUR - PUR	\varnothing 18.9 mm, 4 x 10 mm ² , Black = Phase Brown = Neutral, Yellow - Green = Ground / Protective Earth, Grey = no connection
Connection protected side	1.5 m round cable PUR - PUR	\varnothing 18.9 mm, 4 x 10 mm ² , Black = Phase Brown = Neutral, Yellow-Green = Ground / Protective Earth, Grey = no connection
Operating temperature range	- 40°C / + 85°C	Current to be de-rated above 45°C
Case material		Passivated aluminum
Dimensions	259 x 111 x 71 mm	major dimensions (details see drawing on rear side)
Weight	Approx. 5850 g	Incl. 2 x 1.5 m cables

Dimensions

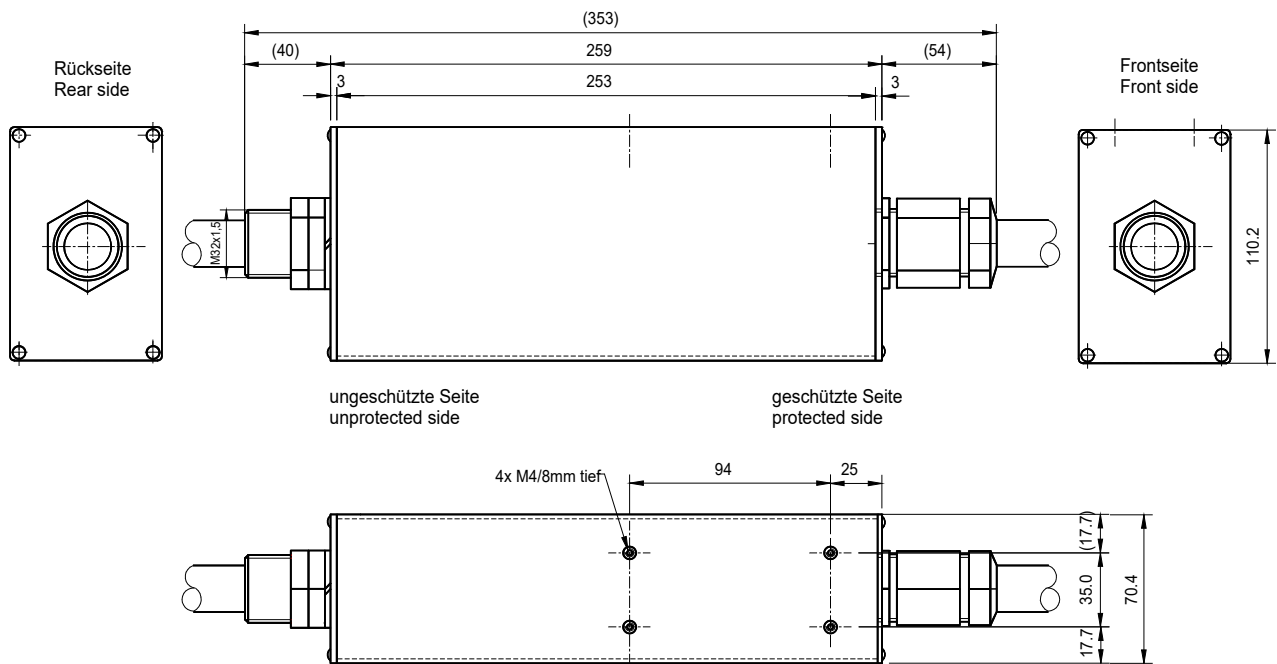

Installation Instructions

- The USP surge protector / filter shall be installed by electrically skilled personnel only.
- The electrical wiring of the unit has to be done according to the national standards and safety regulations.
- Always install Ground / Protective Earth first.
- Yellow-Green = Ground/Protective Earth
Black = Phase
Brown = Neutral
Grey = No Connection
- From the USP surge protector / filter case a secure, low impedance connection to earth has to be made in order to ensure low impedance for discharge surge currents flowing to ground. For best results the thread shall be used to install the protector / filter as feed-through component directly through the wall of the shielded room.

Safety Notes

- The unit does not contain any serviceable parts. Do not attempt to open the device
- Before installation make sure that power is switched off.
- Unauthorized manipulation or damaging of the labels can lead to malfunction or destruction of the USP surge protector / filter and will result in loss of warranty.
- In case of an overvoltage event with visible damages in the protected or unprotected area, the protector / filter unit has to be tested or replaced.

Ordering Information

Part-Nr.: **USP-38101**

Type-Nr.: USP-LNPE-230V-63A-CC101-AA

Contact

Meteolabor AG
Hofstrasse 92
CH-8620 Wetzikon
Switzerland

Tel: +41 44 934 40 40
E-Mail: info@meteolabor.ch
Internet: www.meteolabor.ch

© by Meteolabor AG
All rights reserved

Content may change without further notice 2023-07
USP-38101_e_V2023



EMP Surge Protector / Filter 400 / 230V, 3L + N, 32 A USP-47001, USP series

Overvoltage protector / filter for three phases and neutral 400 / 230 VAC, 50 / 60 Hz power supply lines, up to 32 A

Excellent protection of power supply lines against overvoltages of NEMP / HEMP and lightning (Class II + III) and also against RF interferences

Multi-stage design with common-mode and differential mode protection and integrated filter

Low leakage current (< 0.75 mA)

Threat-level tested against HEMP according to MIL-STD-188-125. For details see chapter "3 User Information"



Product

The Meteolabor USP-47001 surge protector / filter is specially designed for overvoltage protection of power supply lines plus additionally contains an integrated filter for the attenuation of common and differential mode interferences.

The capability to handle high surge currents (up to 40 kA per conductor) ensures best protection against very fast transient overvoltages as they can be generated by NEMP / HEMP, lightning or switching.

Because of their very low leakage current USP series protectors are ideally suited for mobile/portable systems and applications.

Applications

Surge protector / filter elements of the USP series are optimized to protect sensitive units and systems against the effects of overvoltages and fast transients.

USP elements are specially suited to be used in sensitive and mission-critical defence systems (command and control systems, communication, IT installations aso.), in security installations, telecommunication equipment etc..

The universal mechanical design of the USP series offers various ways of mounting the unit as a feed-through component in a Faraday cage. No matter if this is a fixed installation (building, underground shelter) or a mobile container or vehicle.

Technical Data USP-47001

Nominal operating voltage U_N	400 / 230 V AC	50 / 60 Hz
Max. operating voltage U_c	480 / 275 V AC	50 / 60 Hz
Nominal current I_N	32 A	RMS, at T_{amb} 45°C
Surge current nominal I_n	25 kA	multiple, L / N → PE, shape 8 / 20 μ s, T_{amb} 40°C
Max surge current I_{max}	40 kA	min one strike, L / N → PE, shape 8 / 20 μ s, T_{amb} 40°C
Max. differential surge current	20 kA	min one strike, L / N → PE, shape 8 / 20 μ s, T_{amb} 40°C
Residual voltage	< 2 kV	L → PE, shape 8 / 20 μ s, 25 kA
Residual voltage differential	< 1 kV	L → N, shape 8 / 20 μ s, 2 kA, IEC 61000-4-5
AC earth leakage current	< 0.75 mA	L → PE at U_N , 50 Hz (IEC 60950)
DC resistance	typ. 2.7 m Ω	per line, T_{amb} 25 °C, incl. cable
Connection unprotected side	cable, integrated	EPR-PUR orange, 1.5 m, 5 x 4 mm ²
Connection protected side	cable gland in cover terminal, spring clamp	AGRO Progress [®] , stainless steel, clamping range 12.5 – 20.5 mm WAGO CageClamp [®] for cross section 0.08 – 4 mm ² / AWG 28 – 12
Case material		Passivated aluminium
Operating temperature range	- 40°C / + 85°C	
Dimensions	258 x 111 x 71 mm	major dimensions (details see drawing on rear side)
Weight	ca. 4 kg	Incl. cable

EMP Surge Protector / Filter 400 / 230 V, 3L + N, 32 A USP-47101, USP series

Overvoltage protector / filter for three phases and neutral 400 / 230 VAC, 50 / 60 Hz power supply lines, up to 32 A

Excellent protection of power supply lines against overvoltages of NEMP / HEMP and lightning (Class II + III) and also against RF interferences

Multi - stage design with common - mode and differential mode protection and integrated filter

HEMP threat - level tested according to MIL-STD-188-125-1. For details see chapter "3 User Information"

Low leakage current (< 0.75 mA)



The Meteolabor USP-47101 surge protector / filter is specially designed for overvoltage protection of power supply lines plus additionally contains an integrated filter for the attenuation of common and differential mode interferences.

The capability to handle high surge currents (up to 40 kA per conductor) ensures best protection against very fast transient overvoltages as they can be generated by NEMP / HEMP, lightning or switching.

Because of their very low leakage current USP - series protectors are ideally suited for mobile/portable systems and applications.

Applications

Surge protector / filter elements of the USP - series are optimized to protect sensitive units and systems against the effects of overvoltages and fast transients.

USP elements are specially suited to be used in sensitive and mission - critical defence systems (command and control systems, communication, IT installations aso.), in security installations, telecommunication equipment etc..

The universal mechanical design of the USP series offers various ways of mounting the unit as a feed - through component in a Faraday cage. No matter if this is a fixed installation (building, underground shelter) or a mobile container or vehicle.

Technical Data USP-47101

Nominal operating voltage U_N	400 / 230 V AC	50 / 60 Hz
Max. operating voltage U_c	480 / 275 V AC	50 / 60 Hz
Nominal current I_N	32 A	RMS, at T_{amb} 45°C
Surge current nominal I_n	25 kA	multiple, L / N → PE, shape 8 / 20 μ s, T_{amb} 40°C
Max surge current I_{max}	40 kA	min one strike, L / N → PE, shape 8 / 20 μ s, T_{amb} 40°C
Max. differential surge current	20 kA	min one strike, L / N → PE, shape 8 / 20 μ s, T_{amb} 40°C
Residual voltage	< 2 kV	L → PE, shape 8 / 20 μ s, 25 kA
Residual voltage differential	< 1 kV	L → N, shape 8 / 20 μ s, 2 kA, IEC 61000 – 4 - 5
AC earth leakage current	< 0.75 mA	L → PE at U_N , 50 Hz (IEC 60950)
DC resistance	typ. 2.7 m Ω	per line, T_{amb} 25°C, incl. cables
Connection unprotected side	cable, integrated	EPR-PUR orange, 1.5 m, 5 x 4 mm ²
Connection protected side	cable, integrated	EPR-PUR orange, 5 m, 5 x 4 mm ²
Cage material		Passivated aluminium
Operating temperature range	- 40°C / + 85°C	
Dimensions	258 x 111 x 71 mm	major dimensions (details see drawing on rear side)
Weight	ca. 5.3 kg	Incl. cables



EMP Surge Protector / Filter 400 / 230 V, 50 / 60 Hz, 3L+N, 32 A USP-47102, USP series

Overvoltage protector / filter for three phases and neutral 400 / 230 VAC, 50 / 60 Hz power supply lines, up to 32 A

Excellent protection of power supply lines against overvoltages of NEMP / HEMP and lightning (Class II + III) and also against RF interferences

Multi - stage design with common - mode and differential mode protection and integrated filter

HEMP threat - level tested according to MIL-STD-188-125-1. For details see chapter "3 User Information"



The Meteolabor USP-47102 surge protector / filter is specially designed for overvoltage protection of power supply lines plus additionally contains an integrated filter for the attenuation of common and differential mode interferences.

The capability to handle high surge currents (up to 40 kA per conductor) ensures best protection against very fast transient overvoltages as they can be generated by NEMP / HEMP, lightning or switching.

Because of their low leakage current USP series protectors are ideally suited for mobile / portable systems and applications.

Applications

Surge protector / filter elements of the USP - series are optimized to protect sensitive units and systems against the effects of overvoltages and fast transients.

USP elements are specially suited to be used in sensitive and mission - critical defence systems (command and control systems, communication, IT installations etc.), in security installations, telecommunication equipment etc..

The universal mechanical design of the USP - series offers various ways of mounting the unit as a feed - through component in a Faraday cage. No matter if this is a fixed installation (building, underground shelter) or a mobile container or vehicle.

Technical Data USP-47102

Nominal operating voltage U_N	400 / 230 V AC	50 / 60 Hz
Max. operating voltage U_c	480 / 275 V AC	50 / 60 Hz
Nominal current I_N	32 A	RMS, at T_{amb} 45°C
Surge current nominal I_n	25 kA	multiple, L / N → PE, shape 8 / 20 μ s, T_{amb} 40°C
Max surge current I_{max}	40 kA	min one strike, L / N → PE, shape 8 / 20 μ s, T_{amb} 40°C
Max. differential surge current	20 kA	min one strike, L / N → PE, shape 8 / 20 μ s, T_{amb} 40°C
Residual voltage	< 2 kV	L → PE, shape 8 / 20 μ s, 25 kA
Residual voltage differential	< 1 kV	L → N, shape 8 / 20 μ s, 2 kA, IEC 61000-4-5
AC earth leakage current	< 3.5 mA	L → PE at U_N , 50 Hz (IEC 60950)
DC resistance	typ. 20 m Ω	per line, T_{amb} 25°C, incl. cables
Connection unprotected side	5 m round cable	Diameter approx. 25 mm, 5 x AWG6 / 1 x 0.6 mm ² , VG95218 Part 28
Connection protected side	5 m round cable	Diameter approx. 25 mm, 5 x AWG6 / 1 x 0.6 mm ² , VG95218 Part 28
Operating temperature range	- 40°C / + 85°C	Current to be derated above 45°C
Case material		Passivated aluminium
Dimensions	259 x 111 x 71 mm	major dimensions (details see drawing on rear side)
Color	RAL 6031 F9	Contact surfaces on fixing brackets are blank (stainless steel)
Weight	Approx. 22 kg	Incl. cables

Dimensions

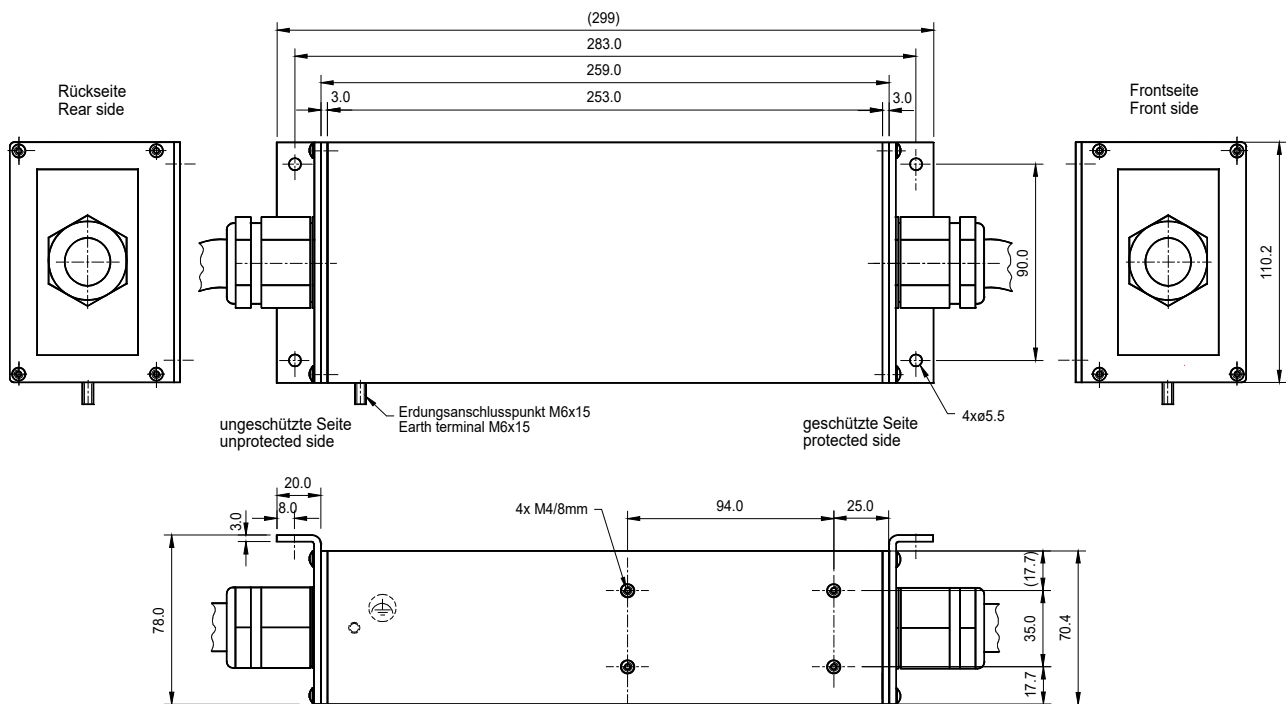

Installation Instructions

- The USP surge protector / filter shall be installed by electrically skilled personnel only.
- The electrical wiring of the unit has to be done according to the national standards and safety regulations.
- The earth terminal of the USP surge protector / filter must be connected to earth in a low impedance manner. For best results the blank contact surfaces of the mounting brackets (stainless steel) shall be installed directly to a locally unpainted metallic structure.
- In case of an overvoltage event with visible damages in the protected or unprotected area, the protector / filter unit has to be tested.

Security Notes

- The unit does not contain any serviceable parts. Attempts to open are strictly forbidden.
- Unauthorized manipulation and handling of the unit can lead to malfunction of the USP surge protector / filter and cause danger to life.
- In case of damaging the labels and / or non - professional manipulation of the unit, warranty will be void plus the proper function of the unit cannot be guaranteed any more.

Ordering Information

Part-Nr.: **USP-47102**

Type-Nr.: USP-3LNPE-400V230V-32A-CC102-AA

Contact

Meteolabor AG
Hofstrasse 92
CH-8620 Wetzikon
Switzerland

Tel: +41 44 934 40 40
E-Mail: info@meteolabor.ch
Internet: www.meteolabor.ch

© by Meteolabor AG
All rights reserved

Content may change without further notice 2023-07
USP-47102_e_V2027

EMP Surge Protector / Filter 400 / 230 V, 3L + N, 25 A USP-47103, USP series

Overvoltage protector / filter for three phases and neutral 400 / 230 VAC, 50 / 60 Hz power supply lines, up to 25 A

Excellent protection of power supply lines against overvoltages of NEMP / HEMP and lightning (Class II + III) and also against RF interferences

Multi - stage design with common - mode and differential mode protection and integrated filter

HEMP threat - level tested according to MIL-STD-188-125-1. For details see chapter "3 User Information"

MIL-847 series connector sockets



The Meteolabor USP-47103 surge protector / filter is specially designed for overvoltage protection of power supply lines plus additionally contains an integrated filter for the attenuation of common and differential mode interferences.

The capability to handle high surge currents (up to 40 kA per conductor) ensures best protection against very fast transient overvoltages as they can be generated by NEMP / HEMP, lightning or switching.

Because of their very low leakage current USP - series protectors are ideally suited for mobile/portable systems and applications.

Applications

Surge protector / filter elements of the USP - series are optimized to protect sensitive units and systems against the effects of overvoltages and fast transients.

USP elements are specially suited to be used in sensitive and mission - critical defence systems (command and control systems, communication, IT installations aso.), in security installations, telecommunication equipment etc..

The universal mechanical design of the USP series offers various ways of mounting the unit as a feed - through component in a Faraday cage. No matter if this is a fixed installation (building, underground shelter) or a mobile container or vehicle.

Technical Data USP-47103

Nominal operating voltage U_N	400 / 230 V AC	50 / 60 Hz
Max. operating voltage U_c	480 / 275 V AC	50 / 60 Hz
Nominal current I_N	25 A	RMS, at T_{amb} 45°C
Surge current nominal I_n	25 kA	multiple, L / N → PE, shape 8 / 20 μ s, T_{amb} 40°C
Max surge current I_{max}	40 kA	min one strike, L / N → PE, shape 8 / 20 μ s, T_{amb} 40°C
Max. differential surge current	20 kA	min one strike, L / N → PE, shape 8 / 20 μ s, T_{amb} 40°C
Residual voltage	< 2 kV	L → PE, shape 8 / 20 μ s, 25 kA
Residual voltage differential	< 1 kV	L → N, shape 8 / 20 μ s, 2 kA, IEC 61000 – 4 - 5
AC earth leakage current	< 3.5 mA	L → PE at U_N , 50 Hz (IEC 60950)
DC resistance	< 10 m Ω	per line, T_{amb} 25°C
Connection unprotected side	847-48-A1-00-N-302	male
Connection protected side	847-48-A5-00-N-302	female
Cage material		Passivated aluminium
Operating temperature range	- 40°C / + 85°C	
Color	RAL 6031 F9	Contact surfaces on fixing brackets are blank (stainless steel)
Dimensions	259 x 111 x 71 mm	major dimensions (details see drawing on rear side)
Weight	approx. 4.4 kg	

Dimensions

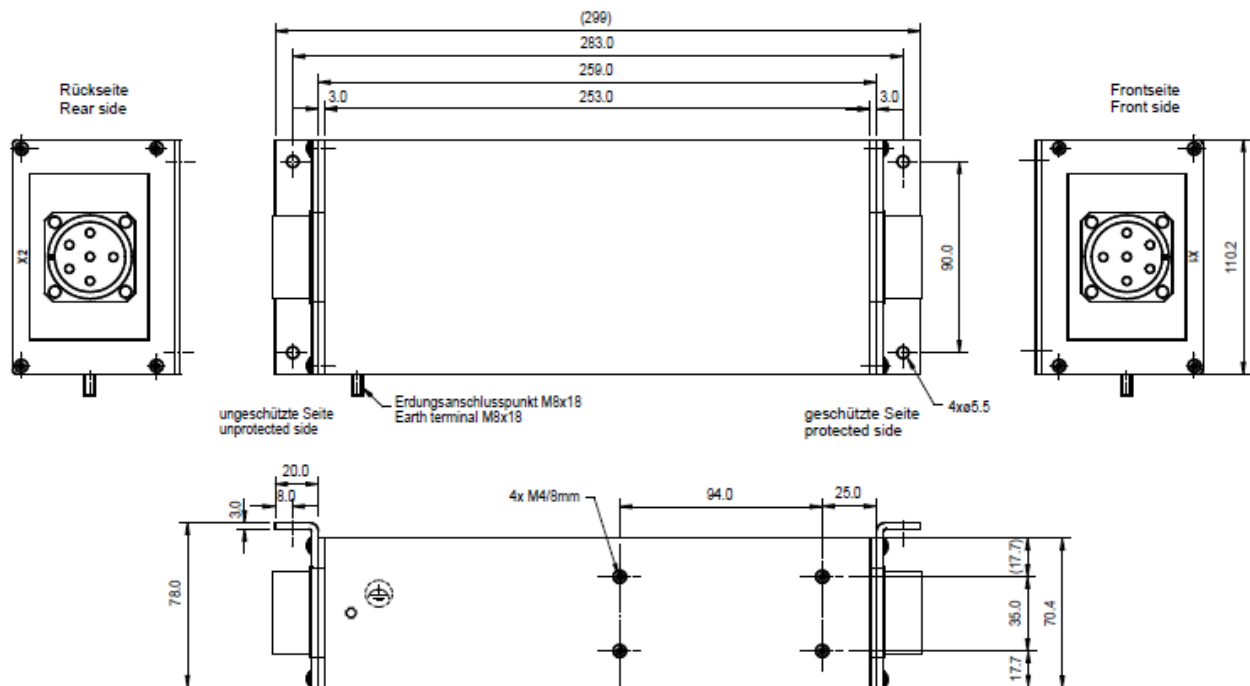

Installation Instructions

- The USP surge protector / filter has to be installed by electrically skilled personnel only.
- The electrical wiring of the unit has to be done according to the national standards and safety regulations.
- From the USP surge protector / filter case a secure, low impedance connection to earth has to be made to ensure sufficient flow of discharge surge currents.
- In case of an overvoltage event with visible damages in the protected or unprotected area, the protector / filter unit has to be tested.

Safety Notes

- The unit does not contain any serviceable parts. Attempts to open are strictly forbidden. Only the cover plate of the terminal area is allowed to be opened to connect the unit.
- Unauthorized manipulation and handling of the unit can lead to malfunction of the USP surge protector / filter and cause danger to life.
- In case of damaging the labels and / or non - professional manipulation of the unit, warranty will be void plus the proper function of the unit cannot be guaranteed any more.

Order Information

Part-Nr.: **USP-47103**

Type-Nr.: USP-3LNPE-400V230V-25-SS103-AA

Contact

Meteolabor AG
Hofstrasse 92
CH-8620 Wetzikon
Switzerland

Tel: +41 44 934 40 40
E-Mail: info@meteolabor.ch
Internet: www.meteolabor.ch

© by Meteolabor AG
All rights reserved

Content may change without further notice 2023-07
USP-47103_e_V2023



EMP Surge Protector / Filter 400 / 230 V, 50 / 60 Hz, 3L+N, 32 A USP-47104

Overvoltage protector / filter for three phases and neutral 400 / 230 VAC, 50 / 60 Hz power supply lines, up to 32 A

Excellent protection of power supply lines against overvoltages of NEMP / HEMP and lightning (Class II + III) and also against RF interferences

Multi - stage design with common - mode and differential mode protection and integrated filter

HEMP threat - level tested according to MIL-STD-188-125-1, short and intermediate pulse shapes

MIL-847 series connector sockets



The Meteolabor USP-47104 surge protector / filter is specially designed for overvoltage protection of power supply lines plus additionally contains an integrated filter for the attenuation of common and differential mode interferences.

The capability to handle high surge currents (up to 40 kA per conductor) ensures best protection against very fast transient overvoltages as they can be generated by NEMP / HEMP, lightning or switching.

Because of their low leakage current USP series protectors are ideally suited for mobile/portable systems and applications.

Applications

Surge protector / filter elements of the USP series are optimized to protect sensitive units and systems against the effects of overvoltages and fast transients.

USP elements are specially suited to be used in sensitive and mission - critical defence systems (command and control systems, communication, IT installations etc.), in security installations, telecommunication equipment etc..

The universal mechanical design of the USP - series offers various ways of mounting the unit as a feed - through component in a Faraday cage. No matter if this is a fixed installation (building, underground shelter) or a mobile container or vehicle.

Technical Data USP-47104

Nominal operating voltage U_N	400 / 230 V AC	50 / 60 Hz
Max. operating voltage U_c	480 / 275 V AC	50 / 60 Hz
Nominal current I_N	32 A	RMS, at T_{amb} 45°C
Surge current nominal I_n	25 kA	multiple, L / N → PE, shape 8 / 20 μ s, T_{amb} 40°C
Max surge current I_{max}	40 kA	min one strike, L / N → PE, shape 8 / 20 μ s, T_{amb} 40°C
Max. differential surge current	20 kA	min one strike, L / N → PE, shape 8 / 20 μ s, T_{amb} 40°C
Residual voltage	< 2 kV	L → PE, shape 8 / 20 μ s, 25 kA
Residual voltage differential	< 1 kV	L → N, shape 8 / 20 μ s, 2 kA, IEC 61000-4-5
AC earth leakage current	< 3.5 mA	L → PE at U_N , 50 Hz (IEC 60950)
DC resistance	< 10 m Ω	per line, T_{amb} 25°C
Connector socket unprotected side	847-58-A1-00-N-302	Male (side marked as X1)
Connector socket protected side	847-58-A5-00-N-302	Female (side marked as X2)
Operating temperature range	- 40°C / + 85°C	Current to be derated above 65°C
Dimensions	259 x 117 x 71 mm	major dimensions (details see drawing on rear side)
Color	RAL 9005 matt black	Contact surfaces on fixing brackets are blank (stainless steel)
Case material		Passivated aluminium
Weight	Approx. 4.8 kg	

Dimensions [mm]

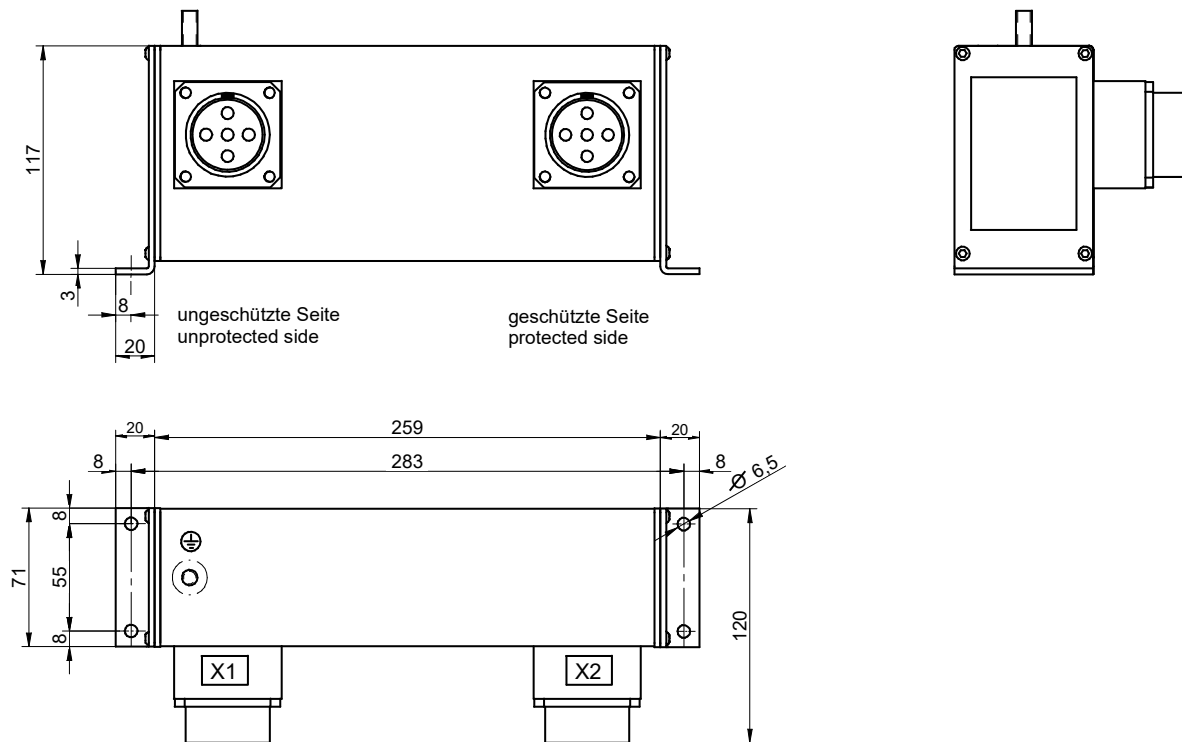

Installation Instructions

- The USP surge protector / filter shall be installed by electrically skilled personnel only.
- The electrical wiring of the unit has to be done according to the national standards and safety regulations.
- The earth terminal of the USP surge protector / filter must be connected to earth in a low impedance manner. For best results the blank contact surfaces of the mounting brackets (stainless steel) shall be installed directly to a locally unpainted metallic structure.
- In case of an overvoltage event with visible damages in the protected or unprotected area, the protector / filter unit has to be tested.

Safety Notes

- The unit does not contain any serviceable parts. Attempts to open are strictly forbidden.
- Unauthorized manipulation and handling of the unit can lead to malfunction of the USP surge protector / filter and cause danger to life.
- In case of damaging the labels and / or non - professional manipulation of the unit, warranty will be void plus the proper function of the unit cannot be guaranteed any more.

Ordering Information

Part-Nr.: **USP-47104**

Type-Nr.: USP-3LNPE-400V230V-32A-SS104-AA

Contact

Meteolabor AG
Hofstrasse 92
CH-8620 Wetzikon
Switzerland

Tel: +41 44 934 40 40
E-Mail: info@meteolabor.ch
Internet: www.meteolabor.ch

© by Meteolabor AG
All rights reserved

Content may change without further notice 2023-07
USP-47104_e_V2023



EMP Surge Protector / Filter 48 V DC, 16 A USP-65001, USP Series

Overvoltage protector / filter for 48V DC power applications up to 16 A

Excellent protection of two conductors of a power supply against HEMP / NEMP and lightning overvoltages and also against RF interferences

Multi-stage design with common-mode and differential mode protection and integrated filter

Coordinated lightning protection Type 2 and 3

Covered spring clamp terminal on protected side

Threat-level tested against HEMP according to MIL-STD-188-125. For details see chapter "3 User Information"



Product

The Meteolabor USP-65001 surge protector / filter combines a multi-stage overvoltage protection for the two wires of a low voltage DC power supply with an integrated high quality filter for the attenuation of common and differential mode interferences.

The capability to handle high surge currents (up to 40 kA per conductor) ensures best protection against very fast transient overvoltages as they can be generated by NEMP / HEMP, lightning or switching.

A cable is integrated into the device on the unprotected side. On the protected side there is a spring clamp terminal block, which permits easy installation of interconnecting cable. A cable gland is integrated into the cover of the terminal block compartment.

Applications

Surge protector / filter elements of the USP series are optimized to protect sensitive units and systems against the effects of overvoltages and fast transients.

USP elements are specially suited to be used in sensitive and mission-critical defence systems (e.g. command and control systems, communication, IT installations), in security installations, telecommunication equipment etc. The USP-series has been successfully used in many projects, where EMP-tests according to RS105 or similar, were done.

The universal mechanical design of the USP series offers various ways of mounting the unit as a feed-through component in a Faraday cage. The low-leakage current design permits safe usage for both, fixed installation (building, underground shelter) and mobile containers or vehicles.

Technical Data USP-65001

Nominal operating voltage U_N	48 V DC / 34 V AC	DC / 50 / 60 Hz
Max. operating voltage U_c	56 V DC / 40 V AC	DC / 50 / 60 Hz
Nominal current I_N	16 A	at T_{amb} 45 °C
Surge current nominal I_n	25 kA	Multiple, +/- → GND, shape 8 / 20 μ s, T_{amb} 40°C
Max surge current I_{max}	40 kA	Single pulse, +/- → GND, shape 8 / 20 μ s, T_{amb} 40°C
Max. differential surge current	5 kA	Single pulse, + → -, shape 8 / 20 μ s, T_{amb} 40 °C
Residual voltage	< 350 V	+,- → GND, Form 8 / 20 μ s, 25 kA
Residual voltage differential	< 200 V	+ → -, Form 8 / 20 μ s, 2 kA, IEC 61000-4-5
DC resistance	11 m Ω typically	Each line, T_{amb} 25°C
Connection unprotected side	cable, integrated	RADOX 125, length 1,5 m, 2 x 2,5 mm ² , shielded
Connection protected side	terminal ,spring clamp	WAGO cage clamp
Case material		Passivated aluminium
Operating temperature range	- 40°C / + 85°C	
Dimensions	275 x 73 x 65 mm	major dimensions (details see drawing on rear side)
Weight	approx. 2.1 kg	

Dimensions

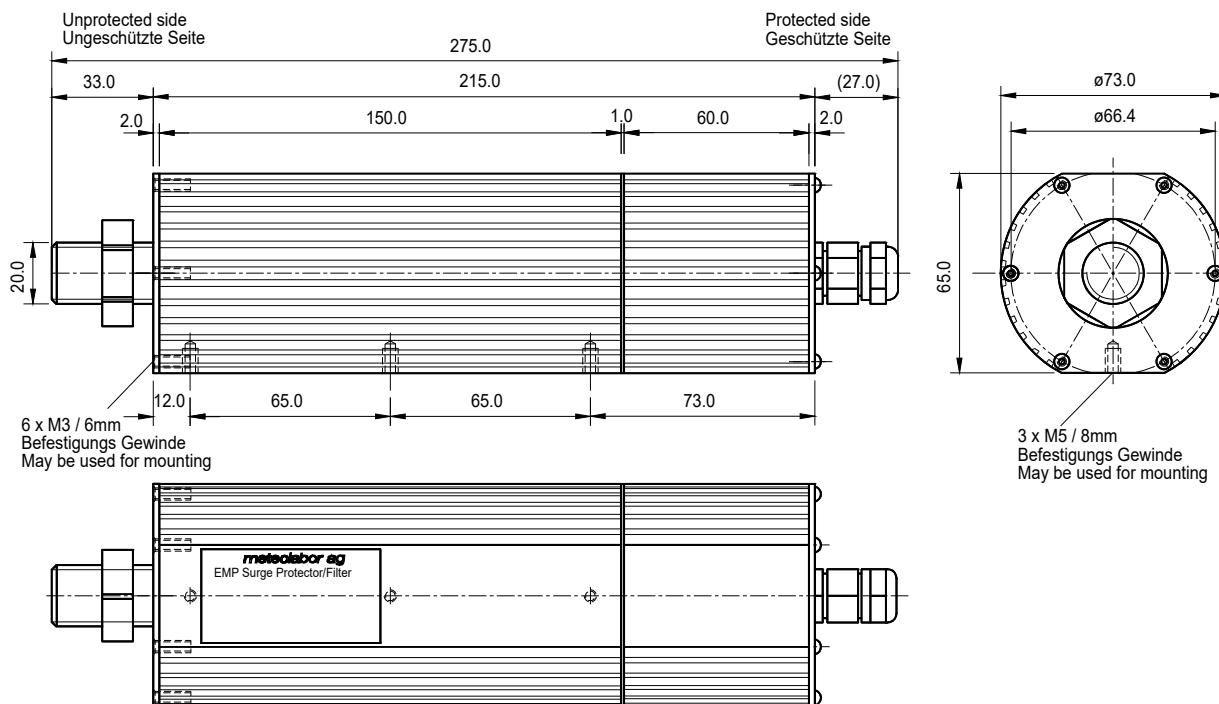

Installation Instructions

- The USP surge protector / filter has to be installed by electrically skilled personnel only.
- The electrical wiring of the unit has to be done according to the national standards and safety regulations.
- Always install Ground / Protective Earth first.
- From the USP surge protector / filter case a secure, low impedance connection to earth has to be made to ensure sufficient flow of discharge surge currents.
- Use a screwdriver for opening the spring clamp to insert or remove wire as shown on picture below.

Safety Notes

- The unit does not contain any serviceable parts. Do not attempt to open the device, only the cover plate of the terminal area is allowed to be opened temporarily in order to install the cable.
- Before opening the cover plate of the terminal area make sure that power is switched off.
- Unauthorized manipulation or damaging of the labels can lead to malfunction or destruction of the USP surge protector/filter and will result in loss of warranty.
- In case of an overvoltage event with visible damages in the protected or unprotected area, the protector/filter unit has to be tested.

Electrical Connection

Unprotected side:

Cable

Brown: Pos. / (+)
Blue: Neg. / (-)
Shield: - GND (Ground / Case)

Protected side:

WAGO CageClamp for wire with end sleeves 0.25-2.5mm² (without 0.08-4mm²)

Grey: Pos. / (+)
Blue: Neg. / (-)
Yellow / Green: GND (Ground / Case)

Protected Side, cover with cable gland removed

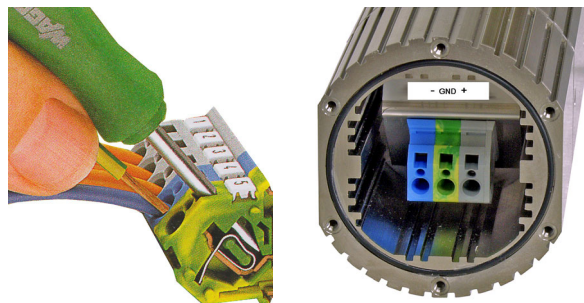

Ordering Information

Part.-Nr.: **USP-65001**

Type-Nr.: USP-2P-48V-16A-CT001-AA

Contact

Meteolabor AG
Hofstrasse 92
CH-8620 Wetzikon
Switzerland

Tel: +41 44 934 40 40
E-Mail: info@meteolabor.ch
Internet: www.meteolabor.ch

© by Meteolabor AG
All rights reserved

Content may change without further notice 2023-07
USP-65001_e_V2023



EMP Surge Protector / Filter 24 V DC, 16 A USP-75001, USP Series

Overvoltage protector / filter for 24V DC power applications up to 16 A

Excellent protection of two conductors of a power supply against HEMP / NEMP and lightning overvoltages and also against RF interferences

Multi-stage design with common-mode and differential mode protection and integrated filter

Coordinated lightning protection Type 2 and 3

Covered spring clamp terminal on protected side

Threat-level tested against HEMP according to MIL-STD-188-125. For details see chapter "3 User Information"



Product

The Meteolabor USP-75001 surge protector / filter combines a multi-stage overvoltage protection for the two wires of a low voltage DC power supply with an integrated high quality filter for the attenuation of common and differential mode interferences.

The capability to handle high surge currents (up to 40 kA per conductor) ensures best protection against very fast transient overvoltages as they can be generated by NEMP / HEMP, lightning or switching.

A cable is integrated into the device on the unprotected side. On the protected side there is a spring clamp terminal block, which permits easy installation of interconnecting cable. A cable gland is integrated into the cover of the terminal block compartment.

Applications

Surge protector / filter elements of the USP series are optimized to protect sensitive units and systems against the effects of overvoltages and fast transients.

USP elements are specially suited to be used in sensitive and mission-critical defence systems (e.g. command and control systems, communication, IT installations), in security installations, telecommunication equipment etc. The USP-series has been successfully used in many projects, where EMP-tests according to RS105 or similar, were done.

The universal mechanical design of the USP series offers various ways of mounting the unit as a feed-through component in a Faraday cage. The low-leakage current design permits safe usage for both, fixed installation (building, underground shelter) and mobile containers or vehicles.

Technical Data USP-75001

Nominal operating voltage U_N	24 V DC / 17 V AC	DC / 50 / 60 Hz
Max. operating voltage U_c	29 V DC / 20 V AC	DC / 50 / 60 Hz
Nominal current I_N	16 A	at T_{amb} 45°C
Surge current nominal I_n	25 kA	Multiple, +/- → GND, shape 8 / 20 μs, T_{amb} 40°C
Max surge current I_{max}	40 kA	Single pulse, +/- → GND, shape 8 / 20 μs, T_{amb} 40°C
Max. differential surge current	5 kA	Single pulse, + → -, shape 8 / 20 μs, T_{amb} 40°C
Residual voltage	< 350 V	+,- → GND, Form 8 / 20 μs, 25 kA
Residual voltage differential	< 200 V	+ → -, Form 8 / 20 μs, 2 kA, IEC 61000-4-5
DC resistance	11 mΩ typically	Each line, T_{amb} 25°C
Connection unprotected side	cable, integrated	RADOX 125, length 1,5 m, 2 x 2,5 mm ² , shielded
Connection protected side	terminal ,spring clamp	WAGO cage clamp, cover plate with integrated cable gland
Case material		Passivated aluminium
Operating temperature range	- 40°C / + 85°C	
Dimensions	275 x 73 x 65 mm	major dimensions (details see drawing on rear side)
Weight	approx. 2.1 kg	



Dimensions

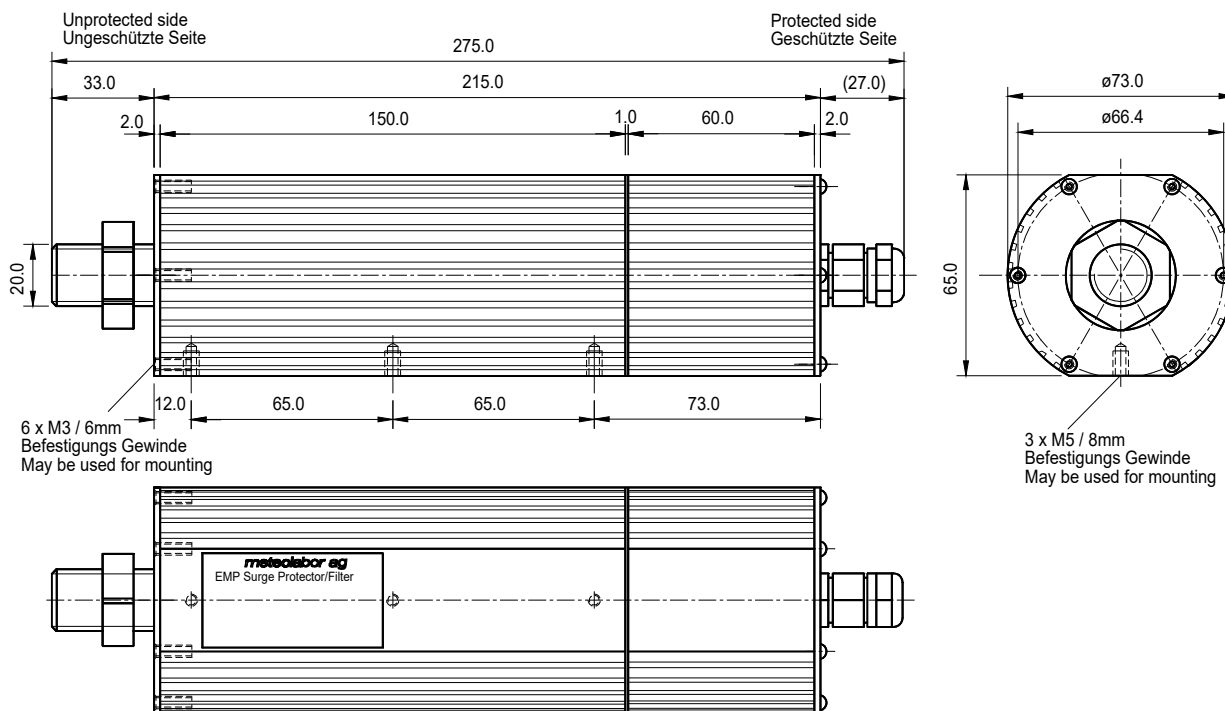

Installation Instructions

- The USP surge protector / filter has to be installed by electrically skilled personnel only.
- The electrical wiring of the unit has to be done according to the national standards and safety regulations.
- Always install Ground / Protective Earth first.
- From the USP surge protector / filter case a secure, low impedance connection to earth has to be made to ensure sufficient flow of discharge surge currents.
- Use a screwdriver for opening the spring clamp to insert or remove wire as shown on picture below.

Safety Notes

- The unit does not contain any serviceable parts. Do not attempt to open the device, only the cover plate of the terminal area is allowed to be opened temporarily in order to install the cable.
- Before opening the cover plate of the terminal area make sure that power is switched off.
- Unauthorized manipulation or damaging of the labels can lead to malfunction or destruction of the USP surge protector/filter and will result in loss of warranty.
- In case of an overvoltage event with visible damages in the protected or unprotected area, the protector/filter unit has to be tested.

Electrical Connection

Unprotected side:

Cable

Brown: Pos. / (+)
 Blue: Neg. / (-)
 Shield: GND (Ground/Case)

Protected side:

WAGO CageClamp for wire with end sleeves 0.25-2.5mm² (without 0.08-4mm²)
 Grey: Pos. / (+)
 Blue: Neg. / (-)
 Yellow / Green: GND (Ground / Case)

Protected Side, cover with cable gland removed

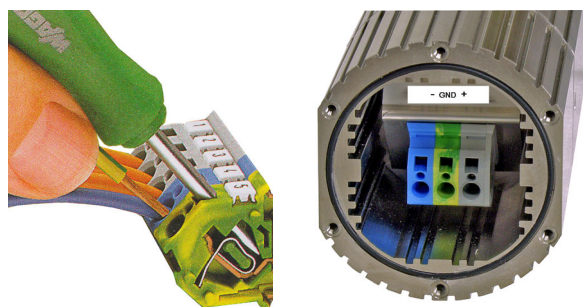

Ordering Information

Part.-Nr.: **USP-75001**
 Type-Nr.: USP-2P-24V-16A-CT001-AA

Contact

Meteolabor AG
 Hofstrasse 92
 CH-8620 Wetzikon
 Switzerland

Tel: +41 44 934 40 40
 E-Mail: info@meteolabor.ch
 Internet: www.meteolabor.ch

© by Meteolabor AG
 All rights reserved
 Content may change without further notice 2023-07
 USP-75001_e_V2023



EMP Surge Protector / Filter 24 V DC, 16 A USP-75101, USP Series

Overvoltage protector / filter for 24V DC power applications up to 16 A

Excellent protection of two conductors of a power supply against HEMP / NEMP and lightning overvoltages and also against RF interferences

Multi-stage design with common-mode and differential mode protection and integrated filter

Coordinated lightning protection Type 2 and 3

Covered spring clamp terminal on protected side

Threat-level tested against HEMP according to MIL-STD-188-125. For details see chapter "3 User Information"



Product

The Meteolabor USP-75101 surge protector / filter combines a multi-stage overvoltage protection for the two wires of a low voltage DC power supply with an integrated high quality filter for the attenuation of common and differential mode interferences.

The capability to handle high surge currents (up to 40 kA per conductor) ensures best protection against very fast transient overvoltages as they can be generated by NEMP / HEMP, lightning or switching.

A cable is integrated into the device on the unprotected side. On the protected side there is a spring clamp terminal block, which permits easy installation of interconnecting cable. A cable gland is integrated into the cover of the terminal block compartment.

Applications

Surge protector / filter elements of the USP series are optimized to protect sensitive units and systems against the effects of overvoltages and fast transients.

USP elements are specially suited to be used in sensitive and mission-critical defence systems (e.g. command and control systems, communication, IT installations), in security installations, telecommunication equipment etc. The USP-series has been successfully used in many projects, where EMP-tests according to RS105 or similar, were done.

The universal mechanical design of the USP series offers various ways of mounting the unit as a feed-through component in a Faraday cage. The low-leakage current design permits safe usage for both, fixed installation (building, underground shelter) and mobile containers or vehicles.

Technical Data USP-75101

Nominal operating voltage U_N	24 V DC / 17 V AC	DC / 50 / 60 Hz
Max. operating voltage U_c	29 V DC / 20 V AC	DC / 50 / 60 Hz
Nominal current I_N	16 A	at T_{amb} 45°C
Surge current nominal I_n	25 kA	Multiple, +/- → GND, shape 8 / 20 μs, T_{amb} 40°C
Max surge current I_{max}	40 kA	Single pulse, +/- → GND, shape 8 / 20 μs, T_{amb} 40°C
Max. differential surge current	5 kA	Single pulse, + → -, shape 8 / 20 μs, T_{amb} 40°C
Residual voltage	< 350 V	+,- → GND, Form 8 / 20 μs, 25 kA
Residual voltage differential	< 200 V	+ → -, Form 8 / 20 μs, 2 kA, IEC 61000-4-5
DC resistance	11 mΩ typically	Each line, T_{amb} 25°C
Connection unprotected side	cable, integrated	RADOX 125, length 1,5 m, 2 x 2,5 mm ² , shielded
Connection protected side	cable, integrated	5.0 m, 2 x 2,5 mm ² , shielded
Case material		Passivated aluminium
Operating temperature range	- 40°C / + 85°C	
Dimensions	275 x 73 x 65 mm	major dimensions (details see drawing on rear side)
Weight	approx. 2.1 kg	

Dimensions

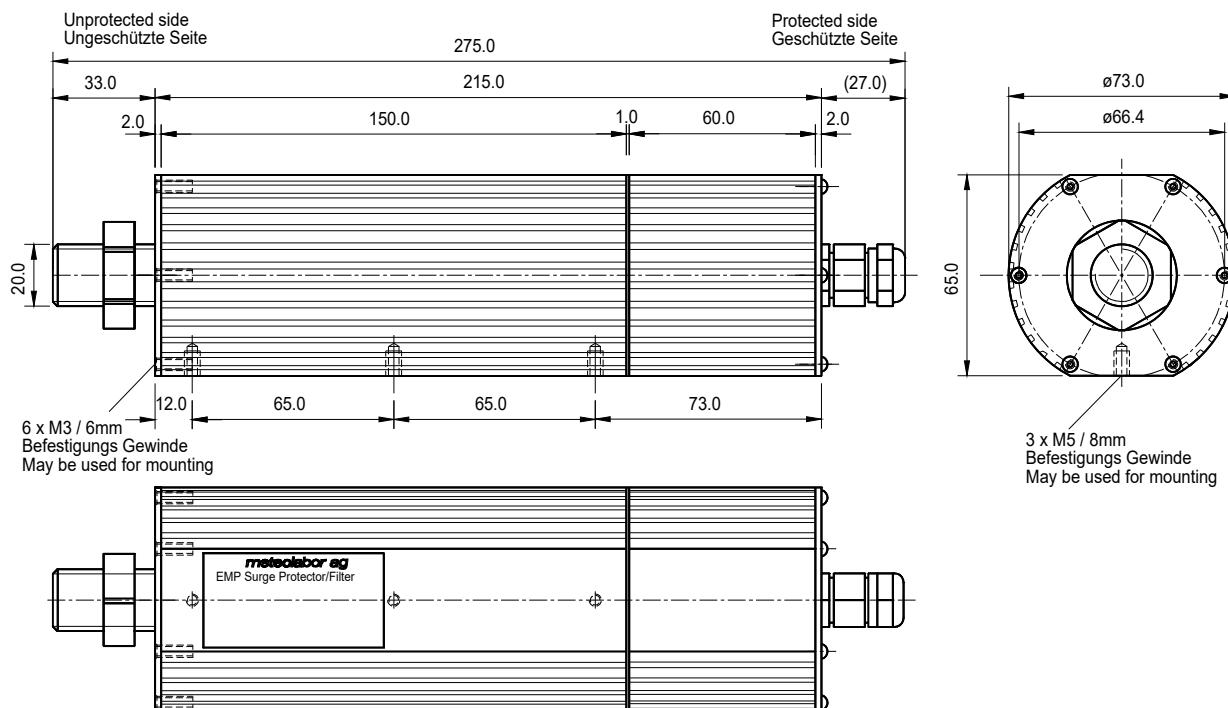

Installation Instructions

- The USP surge protector / filter has to be installed by electrically skilled personnel only.
- The electrical wiring of the unit has to be done according to the national standards and safety regulations.
- Always install Ground / Protective Earth first.
- From the USP surge protector / filter case a secure, low impedance connection to earth has to be made to ensure sufficient flow of discharge surge currents.
- Use a screwdriver for opening the spring clamp to insert or remove wire as shown on picture below.

Safety Notes

- The unit does not contain any serviceable parts. Do not attempt to open the device, only the cover plate of the terminal area is allowed to be opened temporarily in order to install the cable.
- Before opening the cover plate of the terminal area make sure that power is switched off.
- Unauthorized manipulation or damaging of the labels can lead to malfunction or destruction of the USP surge protector/filter and will result in loss of warranty.
- In case of an overvoltage event with visible damages in the protected or unprotected area, the protector/filter unit has to be tested.

Electrical Connection

Unprotected side:

Cable
 Brown: Pos. / (+)
 Blue: Neg. / (-)
 Shield: GND (Ground/Case)

Protected side:

Cable
 Brown: Pos. / (+)
 Blue: Neg. / (-)
 Shield: GND (Ground/Case)

Ordering Information

Part.-Nr.: **USP-75101**

Type-Nr.: USP-2P-24V-16A-CC101-AA

Contact

Meteolabor AG
 Hofstrasse 92
 CH-8620 Wetzikon
 Switzerland

Tel: +41 44 934 40 40
 E-Mail: info@meteolabor.ch
 Internet: www.meteolabor.ch

© by Meteolabor AG
 All rights reserved

Content may change without further notice 2023-07
 USP-75101_e_V2023



EMP Surge Protector / Filter Customer specific DATA modul USP-99101, USP series

Dedicated overvoltage protector / filter for two customer specific data cables

Excellent protection of all signal lines against NEMP / HEMP and lightning overvoltages as well as against RF interferences

Multi-stage protection design with integrated filter

Protection components are HEMP threat-level tested according to MIL-STD-188-125-1. For more information, see chapter 3 "User Information"

Two round connectors MIL-C38999 Series III and one pair of NATO clamps KL65 on unprotected side, two integrated cables on protected side



The Meteolabor USP-99101 surge protector / filter is specially designed for overvoltage protection of customer specific data lines against the effects of NEMP / HEMP or lightning or RF interferences.

The capability to handle high surge currents (up to 20 kA shape 8 / 20µs per conductor) or lightning impulse currents (up to 2.5 kA shape 10 / 350 µs) in a multi-stage protection design ensures best protection against very fast transient overvoltages.

Applications

Surge protector / filter elements of the USP series are optimized to protect sensitive units and systems against the effects of overvoltages and fast transients.

USP elements are specially suited to be used in sensitive and mission-critical defence systems (command and control systems, communication, IT installations aso.), in security installations, telecommunication equipment etc..

Technical Data USP-99101

Case dimensions	196 x 111 x 71 mm	major dimensions (details see drawing on rear side)
Temperature range	-40°C / +85°C	Operating and storage
Color	RAL 6031 F9	Contact surfaces on brackets are blank (stainless steel)
Weight	approx. 2.6 kg	Incl. cables
MIL-connector 11-35		D38999/20WB35SN
Signal name	MAS	Pin 1 to pin 10
Max. operating voltage	48 V	Pin 1 to pin 10
Max. operating current	0.5 A	Pin 1 to pin 10
Max surge current I_{max}	20 kA	Each pin 1 to pin 10 → PE, shape 8 / 20 µs
Protection element	USS-1-48V	One for each pin 1 to pin 10
Cable on protected side	5 m, 5 x 2 x 0.4 mm ²	Cable according VG 95 218 T 028
Diameter of cable	9.2 – 10 mm	Protected side
MIL-connector 13-98		D38999/20WC38PN
Signal name	Audio	Pin A and pin B / clamp KL65 / cable wires 1 and 2
Signal name	Fire Enable	Pin E and pin F / cable wires 5 and 6
Max. operating voltage	48 V	Pin A, B, E, F
Max. operating current	0.5 A	Pin A, B, E, F
Max surge current I_{max}	20 kA	Each pin A, B, E, F → PE, shape 8 / 20 µs
Protection element	USS-1-C / USS-1-48V	One for each pin A, B / E, F
Case material		Passivated aluminium
Cable on protected side	2 m, 5 x 2 x 0.4 mm ²	Cable according VG 95 218 T 028
Diameter of cable	9.2 – 10 mm	Protected side

Dimensions

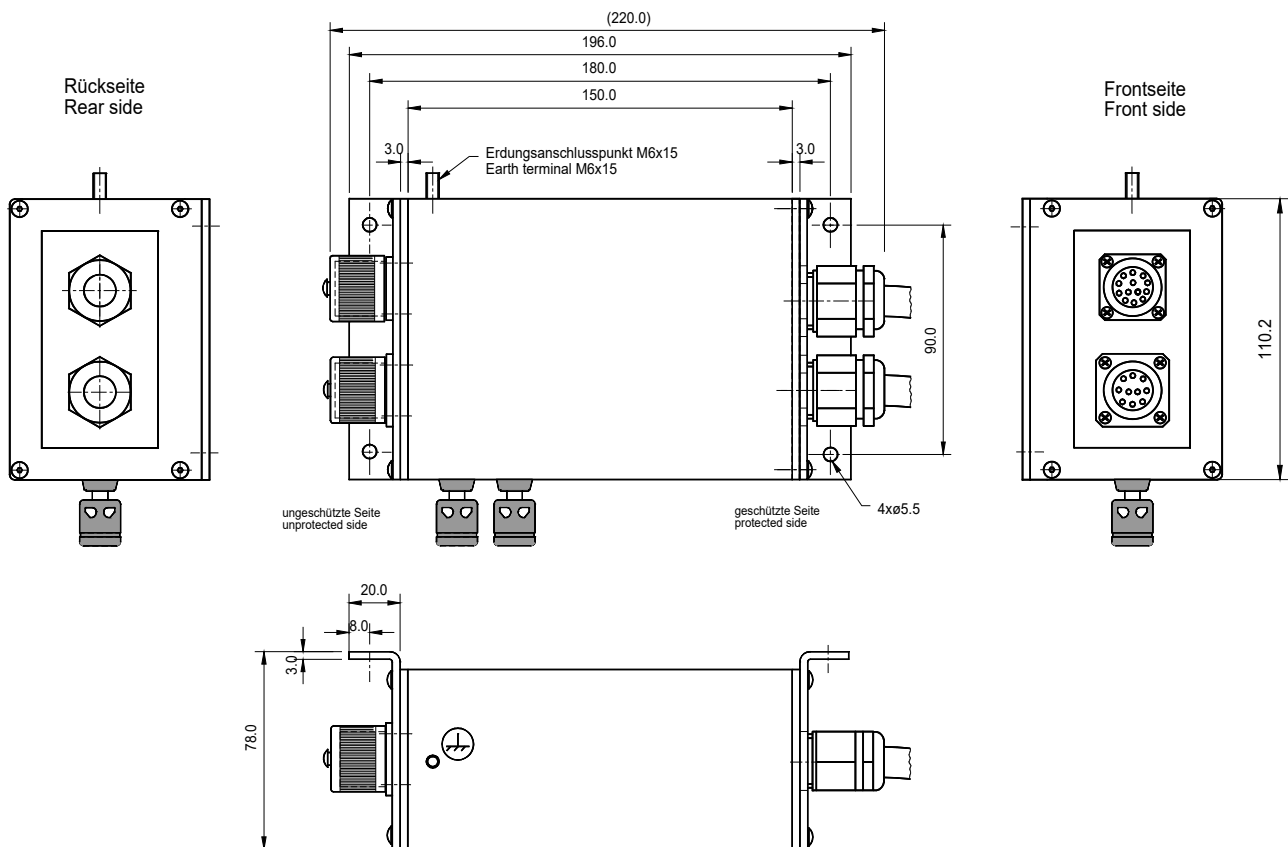

Installation Instructions

- The USP surge protector / filter shall be installed by electrically skilled personnel only.
- The electrical wiring of the unit has to be done according to the national standards and safety regulations.
- The earth terminal of the USP surge protector / filter must be connected to earth in a low impedance manner. For best results the blank contact surfaces of the mounting brackets (stainless steel) shall be installed directly to a locally unpainted metallic structure.
- In case of a transient overvoltage event with visible damages in the protected or unprotected area, the protector / filter unit has to be tested or replaced.

Security Notes

- The unit does not contain any serviceable parts. Attempts to open are strictly forbidden.
- Unauthorized manipulation and handling of the unit can lead to malfunction of the USP surge protector / filter and cause danger to life.
- In case of damaging the labels and / or non-professional manipulation of the unit, warranty will be void plus the proper function of the unit cannot be guaranteed any more.

Ordering Information

Part-Nr.: **USP-99101**

Type-Nr.: USP-DATA-MAS-IC-FS-SC101-AA

Contact

Meteolabor AG
Hofstrasse 92
CH-8620 Wetzikon
Switzerland

Tel: +41 44 934 40 40
E-Mail: info@meteolabor.ch
Internet: www.meteolabor.ch

© by Meteolabor AG
All rights reserved

Content may change without further notice 2023-07
USP-99101_e_V2023

EMP Surge Protector / Filter Customer specific DATA modul USP-99102, USP series

Dedicated overvoltage protector / filter for two customer specific data cables

Excellent protection of all signal lines against NEMP / HEMP and lightning overvoltages as well as against RF interferences

Multi-stage protection design with integrated filter

Protection components are HEMP threat-level tested according to MIL-STD-188-125-1. For more information, see chapter 3 "User Information"

Two MIL-C38999 sockets with covers and one pair of NATO clamps KL65 on unprotected side, two MIL-C38999 sockets on protected side



The Meteolabor USP-99102 surge protector / filter is specially designed for overvoltage protection of customer specific data lines against the effects of NEMP / HEMP or lightning or RF interferences.

The capability to handle high surge currents (up to 20 kA shape 8 / 20µs per conductor) or lightning impulse currents (up to 2.5 kA shape 10 / 350 µs) in a multi-stage protection design ensures best protection against very fast transient overvoltages.

Applications

Surge protector / filter elements of the USP series are optimized to protect sensitive units and systems against the effects of overvoltages and fast transients.

USP elements are specially suited to be used in sensitive and mission-critical defence systems (command and control systems, communication, IT installations aso.), in security installations, telecommunication equipment etc..

Technical Data USP-99102

Case dimensions	196 x 111 x 71 mm	major dimensions (details see drawing on rear side)
Temperature range	-40°C / +85°C	Operating and storage
Color	RAL 6031 F9	Contact surfaces on brackets are blank (stainless steel)
Weight	approx. 1.5 kg	

Connector socket: MIL 38999 / 20 W B 35 SN (unprotectd side)

MIL 38999 / 20 W B 35 PN (protected side)

Pin to pin wiring (unprotected – protected)	1-1, 2-2, 3-3, 4-4, 5-5, 6-6, 7-7, 8-8, 9-9, 10-10, pins 11 - 13 are not connected, pins inserted
Signal name	MAS Pins 1 to 10
Max. operating voltage	48 V Each pin 1 to pin 10, voltage between pin and ground
Max. operating current	0.5 A Each pin 1 to pin 10
Max surge current I_{max}	20 kA Each pin 1 to pin 10 → PE, shape 8 / 20 µs
Protection element	USS-1-48V One for each pin1 to pin 10

Connector socket: MIL 38999 / 20 W C 98 SN (unprotectd side)

MIL 38999 / 20 W B 98 SN (protected side)

Pin to pin wiring (unprotected – protected)	A-A, B-B, E-E, F-F, pins C, D, G, H, J, K are not connected, pins inserted
Signal name	Audio Pins A and B, clamp KL65 connected to A and B (unprotected side)
Protection element	USS-1-C One for each pin A and B
Signal name	Fire Enable Pins E and F
Protection element	USS-1-48V One for each pin E and F
Max. operating voltage	48 V Each pin A, B, E, F, voltage between pin and ground
Max. operating current	0.5 A Each pin A, B, E, F
Max surge current I_{max}	20 kA Each pin A, B, E, F → PE, shape 8 / 20 µs

Dimensions

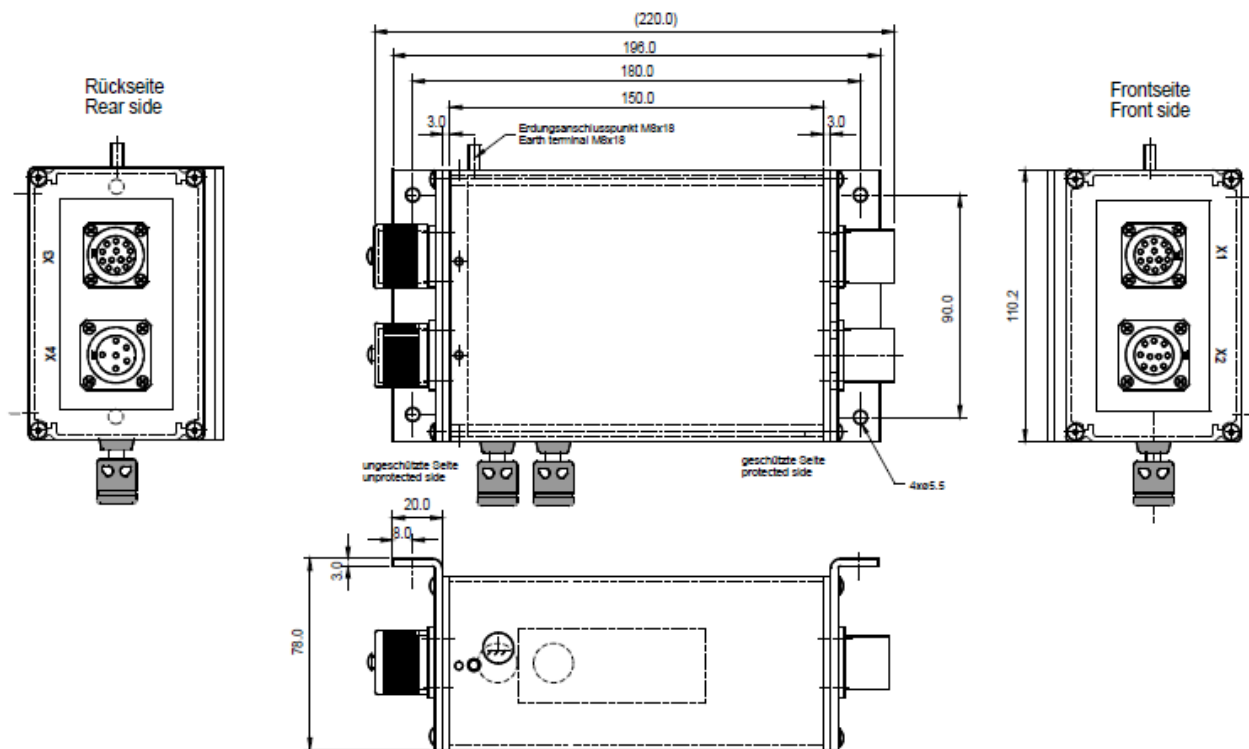

Installation Instructions

- The USP surge protector / filter shall be installed by electrically skilled personnel only.
- The electrical wiring of the unit has to be done according to the national standards and safety regulations.
- The earth terminal of the USP surge protector / filter must be connected to earth in a low impedance manner. For best results the blank contact surfaces of the mounting brackets (stainless steel) shall be installed directly to a locally unpainted metallic structure.
- In case of a transient overvoltage event with visible damages in the protected or unprotected area, the protector / filter unit has to be tested or replaced.

Security Notes

- The unit does not contain any serviceable parts. Attempts to open are strictly forbidden.
- Unauthorized manipulation and handling of the unit can lead to malfunction of the USP surge protector / filter and cause danger to life.
- In case of damaging the labels and / or non-professional manipulation of the unit, warranty will be void plus the proper function of the unit cannot be guaranteed any more.

Ordering Information

Part-Nr.: **USP-99102**

Type-Nr.: USP-DATA-MAS-IC-FS-SS102-AA

Contact

Meteolabor AG
Hofstrasse 92
CH-8620 Wetzikon
Switzerland

Tel: +41 44 934 40 40
E-Mail: info@meteolabor.ch
Internet: www.meteolabor.ch

© by Meteolabor AG
All rights reserved

Content may change without further notice 2023-07
USP-99102_e_V2027





PLP Series

Lightning and EMP-Protection for Powerlines of Fixed Installations



EMP Surge Protector / Filter 3 parts (3L) 400 / 230 V, 1000 A PLP-34011, PLP Series

Excellent protection of 3 lines (3L) 400 / 230 V (50 / 60 Hz) for power supply applications in fixed installations up to 1000 A per phase

Protection against HEMP / NEMP- and lightning overvoltages as well as against RF - interferences

Multi-stage protection / filter design providing very high transient energy absorption capability

Thermally monitored Surge Protection Devices with status signalization by potential free contact

Rigid stainless steel construction for direct installation to Faraday cage, approved for 3 bar blast shock according to BZS / BABS - Standard



Meteolabor PLP-Series EMP Protector / Filter consist of Combinations of coarse and fine protection stages in combination with filtering components. This guarantees optimized protection of mission critical equipment against very fast transient overvoltages (e.g. NEMP / HEMP).

The PLP-Series is threat-level tested against EMP according to MIL-STD-188-125-1, short pulse and intermediate pulse.

Extremely high surge currents up to 100 kA (8 / 20µs) per line can be diverted.

For safety a capacitor discharge resistor is built in.

Applications

Meteolabor EMP-Protector / Filters protect sensitive electronics such as Computers, telecommunication equipment, controls etc. from damages due to NEMP / HEMP or lightning effects.

Radio frequency interferences are filtered by high quality low-pass filters. The filter is designed for fixed installation with permanent grounding.

Applications range from fixed military facilities (e.g. C⁴I facilities) to civilian or industrial projects requiring high reliability.

Technical Data PLP-34011

Nominal voltage U_N	3 x 400 / 230 V AC	50 / 60 Hz
Max. operating voltage U_c	3 x 460 / 255 V AC	50 / 60 Hz
Nominal current I_N	1000 A	Effective at T_{amb} 40°C
Max. surge current I_{Max}	100 kA	Each L / N → PE, shape 8 / 20 µs, T_{amb} 40°C, at least 1 pulse
Max. lightning impulse current I_{imp}	25 kA	Each L / N → PE, shape 10 / 350 µs, T_{amb} 40°C, at least 1 pulse
DC resistance	< 0.3 mΩ	Each path L / N
Residual voltage HEMP - Condition	< 50 V	L / N → PE, short pulse according MIL-STD-188-125-1
Residual voltage surge	< 1 kV	L / N → PE, pulse 4 kV / 2 kA according to IEC 61000-4-5
Attenuation	> 80 dB	200 kHz – 1 GHz, 50 Ω - System
50 Hz AC-leakage current	< 3.5 A	L → PE at U_N , 50 Hz
Combination Surge Protection Device	SPD Type 1 + 2	Fault indication by opening of a potential-free contact
Potential free contact of SPD	Normally closed	Max. 250 V AC, 0.5 A, open if at least one SPD has disconnected
Case material	Steel V 2 A	Central cover is made from aluminum
Dimensions (estimated)	1360x804x129 mm	External dimensions
Weight (estimated)	Approx. 453 kg	Total weight (3 boxes, each 151 kg)
Approval Number BZS	LS S07-911	Shock (3 bar) according BABS / BZS

Dimensions (Single case of three cases)

Note: The 1000A EMP-Protection consists of 3 identical cases (one for each phase / neutral)

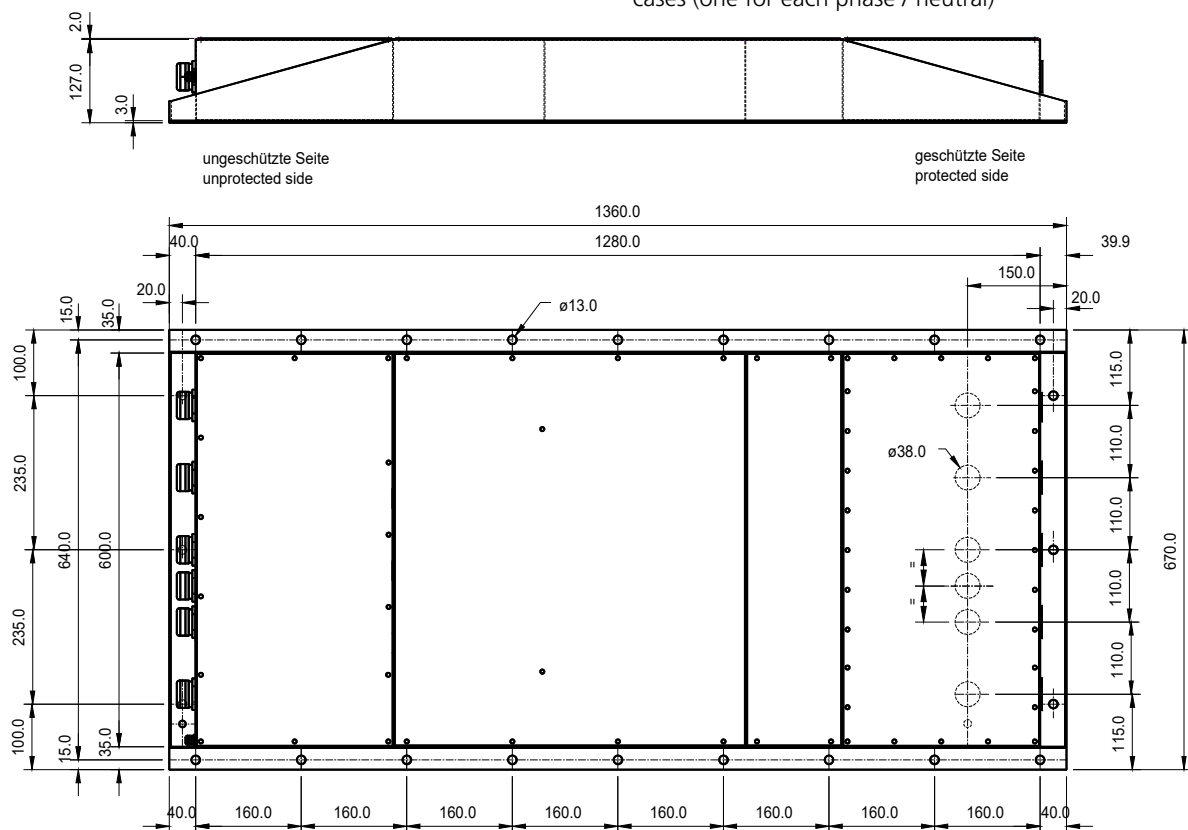

Installation Notes

- The EMP protector / filter has to be installed by electrically skilled personnel.
- The electrical wiring has to be done according to local regulations.
- The max. values stated in this datasheet must not be exceeded under any circumstances.
- PLP-series EMP protector / filter shall be permanently (not pluggable) connected to the grid.
- Residual current circuit breakers shall be used on the protected side of the surge protector, where they are protected from transient overvoltages.
- The EMP protector / filter may be directly installed to a Faraday cage as feed-through device. Otherwise the cabling on the protected side must be shielded.
- Do not use spacers between filter and Faraday cage.
- The screws of the covers shall be slightly lubricated for best performance.

Ordering Information

Part.-Nr: **PLP-34011**

Type-Nr.: USS-3x230V/1000A/EMP-M

Installation Instruction for mechanical shock protection

- The PLP-Series is approved for 3 bar shock protection according to Swiss Federal Office for Civil Protection (BABS, formerly BZS).
- Installation can be done by screws or direct welding to the Faraday cage. Usually installation using screws or bolts is more convenient.
- If screwed at least 10 pieces equally spaced screws M12 of class 8.8 including washer and spring washer shall be used. The torque shall be 83 Nm. Using more screws improves the electrical contact with the Faraday cage.
- Installation to a concrete wall requires at least 10 dowels approved by BABS. Each dowel shall have at least the capability to hold 5.2 kN.
- If welded at least 10 equally spaced fillet welds having a length of 50 mm shall be applied.



Warning

High AC earth leakage current! Case of filter (Protective earth) must be solidly and permanently earthed. Always install protective earth first.

Contact

Meteolabor AG
Hofstrasse 92
CH-8620 Wetzikon
Switzerland

Tel: +41 44 934 40 40
E-Mail: info@meteolabor.ch
Internet: www.meteolabor.ch

© by Meteolabor AG
All rights reserved

Content may change without further notice 2023-07
PLP-34011_e_V2023

EMP Surge Protector / Filter 4 parts (3L+N) 400 / 230 V, 1000 A PLP-44011, PLP Series

Excellent protection of 4 lines (3L+N) 400 / 230 V (50 / 60Hz) for power supply applications in fixed installations up to 1000 A per phase

Protection against HEMP / NEMP- and lightning overvoltages as well as against RF - interferences

Multi - stage protection / filter design providing very high transient energy absorption capability

Thermally monitored Surge Protection Devices with status signalization by potential free contact

Rigid stainless steel construction for direct installation to Faraday cage, approved for 3 bar blast shock according to BZS / BABS - Standard



Meteolabor PLP-Series EMP Protector / Filter consist of Combinations of coarse and fine protection stages in combination with filtering components. This guarantees optimized protection of mission critical equipment against very fast transient overvoltages (e.g. NEMP / HEMP).

The PLP-Series is threat-level tested against EMP according to MIL-STD-188-125-1, short pulse and intermediate pulse.

Extremely high surge currents up to 100 kA (8 / 20µs) per line can be diverted.

For safety a capacitor discharge resistor is built in.

Applications

Meteolabor EMP-Protector / Filters protect sensitive electronics such as Computers, telecommunication equipment, controls etc. from damages due to NEMP / HEMP or lightning effects.

Radio frequency interferences are filtered by high quality low-pass filters. The filter is designed for fixed installation with permanent grounding.

Applications range from fixed military facilities (e.g. C⁴I facilities) to civilian or industrial projects requiring high reliability.

Technical Data PLP-44011

Nominal voltage U_N	3 x 400 / 230 V AC	50 / 60 Hz
Max. operating voltage U_c	3 x 460 / 255 V AC	50 / 60 Hz
Nominal current I_N	1000 A	Effective at T_{amb} 40°C
Max. surge current I_{Max}	100 kA	Each L / N → PE, shape 8 / 20 µs, T_{amb} 40°C, at least 1 pulse
Max. lightning impulse current I_{imp}	25 kA	Each L / N → PE, shape 10 / 350 µs, T_{amb} 40°C, at least 1 pulse
DC resistance	< 0.3 mΩ	Each path L / N
Residual voltage HEMP-condition	< 50 V	L / N → PE, short pulse according MIL-STD-188-125-1
Residual voltage surge	< 1 kV	L / N → PE, pulse 4 kV / 2 kA according to IEC 61000-4-5
Attenuation	> 80 dB	200 kHz – 1 GHz, 50 Ω - System
50 Hz AC-leakage current	< 3.5 A	L → PE at U_N , 50 Hz
Combination Surge Protection Device	SPD Type 1 + 2	Fault indication by opening of a potential-free contact
Potential free contact of SPD	Normally closed	Max. 250 V AC, 0.5 A, open if at least one SPD has disconnected
Case material	Steel V 2 A	Central cover is made from aluminum
Dimensions (estimated)	1360x804x129 mm	External dimensions
Weight (estimated)	Approx. 604 kg	Total weight (4 boxes, each 151 kg)
Approval Number BZS	LS S07-911	Shock (3 bar) according BABS / BZS



Dimensions (Single case of four cases)

Note: The 1000A EMP-Protection consists of 4 identical cases (one for each phase / neutral)

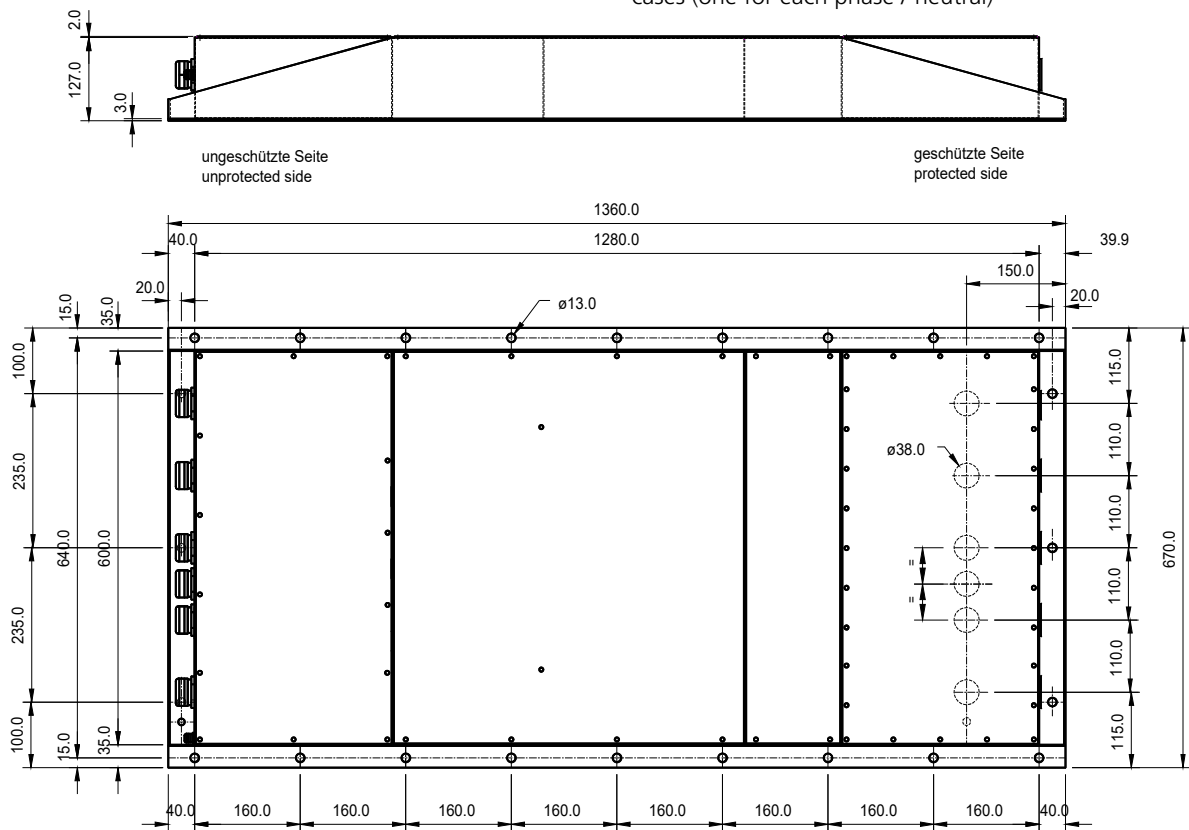

Installation Notes

- The EMP protector / filter has to be installed by electrically skilled personnel.
- The electrical wiring has to be done according to local regulations.
- The max. values stated in this datasheet must not be exceeded under any circumstances.
- PLP-series EMP protector / filter shall be permanently (not pluggable) connected to the grid.
- Residual current circuit breakers shall be used on the protected side of the surge protector, where they are protected from transient overvoltages.
- The EMP protector/filter may be directly installed to a Faraday cage as feed - through device. Otherwise the cabling on the protected side must be shielded.
- Do not use spacers between filter and Faraday cage.
- The screws of the covers shall be slightly lubricated for best performance.

Installation Instruction for mechanical shock protection

- The PLP-Series is approved for 3 bar shock protection according to Swiss Federal Office for Civil Protection (BABS, formerly BZS).
- Installation can be done by screws or direct welding to the Faraday cage. Usually installation using screws or bolts is more convenient.
- If screwed at least 10 pieces equally spaced screws M12 of class 8.8 including washer and spring washer shall be used. The torque shall be 83 Nm. Using more screws improves the electrical contact with the Faraday cage.
- Installation to a concrete wall requires at least 10 dowels approved by BABS. Each dowel shall have at least the capability to hold 5.2 kN.
- If welded at least 10 equally spaced fillet welds having a length of 50 mm shall be applied.

Ordering Information

Part.-Nr: **PLP-44011**
 Type-Nr.: USS-3x400/230V/1000A/EMP-M

Warning
 High AC earth leakage current! Case of filter (Protective earth) must be solidly and permanently earthed. Always install protective earth first.

Contact

Meteolabor AG
 Hofstrasse 92
 CH-8620 Wetzikon
 Switzerland

Tel: +41 44 934 40 40
 E-Mail: info@meteolabor.ch
 Internet: www.meteolabor.ch

© by Meteolabor AG
 All rights reserved

Content may change without further notice 2023-07
 PLP-44011_e_2023

EMP Surge Protector / Filter 4 lines (3L + N) 400 / 230 V, 30 A PLP-44031, PLP Series

Excellent protection of 4 lines (3L + N) 400 / 230 V (50 / 60 Hz) for power supply applications up to 30 A of fixed installations

Protection against NEMP / HEMP and lightning overvoltages as well as against RF - interferences

Multi - stage protection / filter design providing very high transient energy absorption capability

Thermally monitored Surge Protection Devices with status signalization by potential free contact

Rigid stainless steel construction for direct installation to Faraday cage, approved for 3 bar blast shock according to BZS / BABS - Standard



Meteolabor PLP-Series EMP Protector / Filter consist of Combinations of coarse and fine protection stages in combination with filtering components. This guarantees optimized protection of mission critical equipment against very fast transient overvoltages (e.g. NEMP / HEMP).

The PLP-Series is threat-level tested against EMP according to MIL-STD-188-125-1, short pulse and intermediate pulse.

Extremely high surge currents up to 100 kA (8 / 20µs) per line can be diverted.

For safety a capacitor discharge resistor is built in.

Applications

Meteolabor EMP-Protector / Filters protect sensitive electronics such as Computers, telecommunication equipment, controls etc. from damages due to NEMP / HEMP or lightning effects.

Radio frequency interferences are filtered by high quality low - pass filters. The filter is designed for fixed installation with permanent grounding.

Applications range from fixed military facilities (e.g. C⁴I facilities) to civilian or industrial projects requiring high reliability.

Technical Data PLP-44031

Nominal voltage U_N	3 x 400 / 230 V AC	50 / 60 Hz
Max. operating voltage U_c	3 x 460 / 255 V AC	50 / 60 Hz
Nominal current I_N	30 A	Effective at T_{amb} 40°C
Max. surge current I_{Max}	100 kA	Each L / N → PE, shape 8 / 20 µs, T_{amb} 40°C, at least 1 pulse
Max. lightning impulse current I_{Imp}	25 kA	Each L / N → PE, shape 10 / 350 µs, T_{amb} 40°C, at least 1 pulse
DC resistance	< 6.5 mΩ	Each L / N
Residual voltage HEMP-condition	< 60 V	L/N → PE, short pulse according MIL-STD-188-125-1
Residual voltage surge	< 1 kV	L/N → PE, pulse 4 kV / 2 kA according to IEC 61000-4-5
Attenuation	> 80 dB	200 kHz – 1 GHz, 50 Ω - System
50 Hz AC-leakage current	< 0.7 A	L → PE at U_N , 50 Hz
Combination Surge Protection Device	SPD Type 1 + 2	Fault indication by opening of a potential-free contact
Potential free contact	Normally closed	Max. 250 V AC, 0.5 A, open if at least one SPD has disconnected
Case material	Steel V 2 A	Central cover made from aluminium
Dimensions	750x370x129 mm	External dimensions, Details see drawing
Weight	approx. 32 kg	
Approval Number BZS	LS S07-911	Shock (3 bar) according BABS / BZS



Dimensions

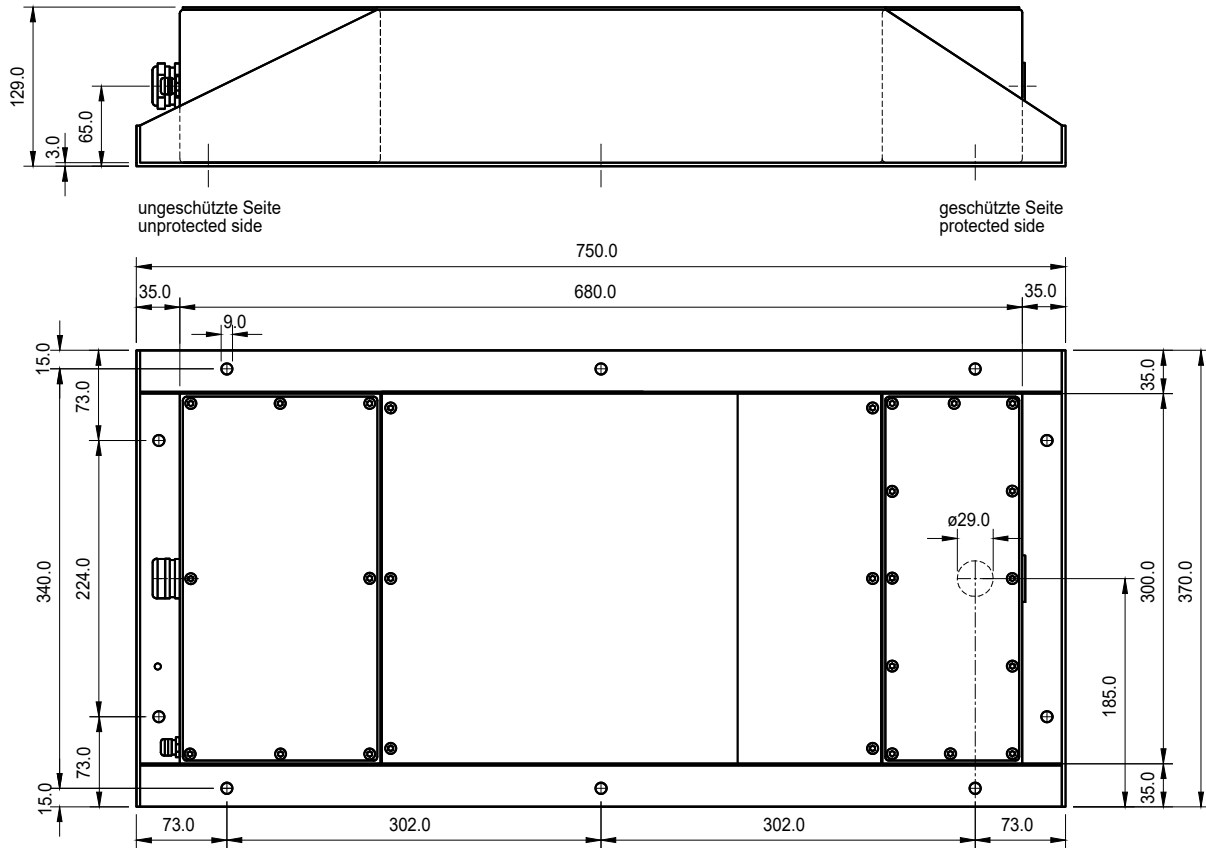

Installation Notes

- The EMP protector / filter has to be installed by electrically skilled personnel.
- The electrical wiring has to be done according to local regulations.
- The max. values stated in this datasheet must not be exceeded under any circumstances.
- PLP-series EMP protector/filter shall be permanently (not pluggable) connected to the grid.
- Residual current circuit breakers shall be used on the protected side of the surge protector, where they are protected from transient overvoltages.
- The EMP protector/filter may be directly installed to a Faraday cage as feed-through device. Otherwise the cabling on the protected side must be shielded.
- Do not use spacers between filter and Faraday cage.
- The screws of the covers shall be slightly lubricated for best performance.

Installation Instruction for mechanical shock protection

- The PLP-Series is approved for 3 bar shock protection according to Swiss Federal Office for Civil Protection (BABS, formerly BZS).
- Installation can be done by screws or direct welding to the Faraday cage. Usually installation using screws or bolts is more convenient.
- If screwed at least 4 pieces equally spaced screws M8 of class 8.8 including washer and spring washer shall be used. The torque shall be 83 Nm. Using more screws improves the electrical contact with the Faraday cage.
- Installation to a concrete wall requires at least 4 dowels approved by BABS. Each dowel shall have at least the capability to hold 2.3 kN.
- If welded at least 4 equally spaced fillet welds having a length of 50 mm shall be applied.

Ordering Information

Part.-Nr: **PLP-44031**
 Type-Nr.: USS-3x400/230V/30A/EMP-M

Warning
 High AC earth leakage current! Case of filter (Protective earth) must be solidly and permanently earthed. Always install protective earth first.

Contact

Meteolabor AG
 Hofstrasse 92
 CH-8620 Wetzikon
 Switzerland

Tel: +41 44 934 40 40
 E-Mail: info@meteolabor.ch
 Internet: www.meteolabor.ch

© by Meteolabor AG
 All rights reserved

Content may change without further notice 2023-07
 PLP-44031_e_V2027

EMP Surge Protector / Filter 4 lines (3L+N) 400 / 230 V, 40 A PLP-44041, PLP Series

Excellent protection of 4 lines (3L + N) 400 / 230 V (50 / 60 Hz) for power supply applications up to 40 A of fixed installations

Protection against NEMP / HEMP and lightning overvoltages as well as against RF-interferences

Multi-stage protection/filter design providing very high transient energy absorption capability

Thermally monitored Surge Protection Devices with status signalization by potential free contact

Rigid stainless steel construction for direct installation to Faraday cage, approved for 3 bar blast shock according to BZS / BABS - Standard



Product

Meteolabor PLP-Series EMP Protector/Filter consist of Combinations of coarse and fine protection stages in combination with filtering components. This guarantees optimized protection of mission critical equipment against very fast transient overvoltages (e.g. NEMP / HEMP).

The PLP-Series is threat-level tested against EMP according to MIL-STD-188-125-1. For details see chapter "3 User Information"

Extremely high surge currents up to 100 kA (8/20 μ s) per line can be diverted.

For safety a capacitor discharge resistor is built in.

Applications

Meteolabor EMP-Protector/Filters protect sensitive electronics such as Computers, telecommunication equipment, controls etc. from damages due to NEMP / HEMP or lightning effects.

Radio frequency interferences are filtered by high quality low-pass filters. The filter is designed for fixed installation with permanent grounding.

Applications range from fixed military facilities (e.g. C⁴ facilities) to civilian or industrial projects requiring high reliability.

Technical Data PLP-44041

Nominal voltage U_N	3 x 400 / 230 V AC	50 / 60 Hz
Max. operating voltage U_c	3 x 460 / 255 V AC	50 / 60 Hz
Nominal current I_N	40 A	Effective at T_{amb} 40 °C
Max. surge current I_{Max}	100 kA	Each L / N \rightarrow PE, shape 8 / 20 μ s, T_{amb} 40°C, at least 1 pulse
Max. lightning impulse current I_{Imp}	25 kA	Each L / N \rightarrow PE, shape 10 / 350 μ s, T_{amb} 40°C, at least 1 pulse
DC resistance	< 6.5 m Ω	Each L / N
Residual voltage surge	< 1 kV	L / N \rightarrow PE, pulse 4 kV / 2 kA according to IEC 61000-4-5
Attenuation	> 80 dB	200 kHz – 1 GHz, 50 Ω - System
50 Hz AC-leakage current	< 0.7 A	L \rightarrow PE at U_N , 50 Hz
Combination Surge Protection Device	SPD Type 1 + 2	Fault indication by opening of a potential-free contact
Potential free contact	Normally closed	Max. 250 V AC, 0.5 A, open if at least one SPD has disconnected
Case material	Steel V2A	Central cover made from aluminium
Dimensions	750 x 370 x 129 mm	External dimensions, Details see drawing
Weight	approx. 32 kg	
Approval Number BZS	LS S07-911	Shock (3 bar) according BABS / BZS



Dimensions

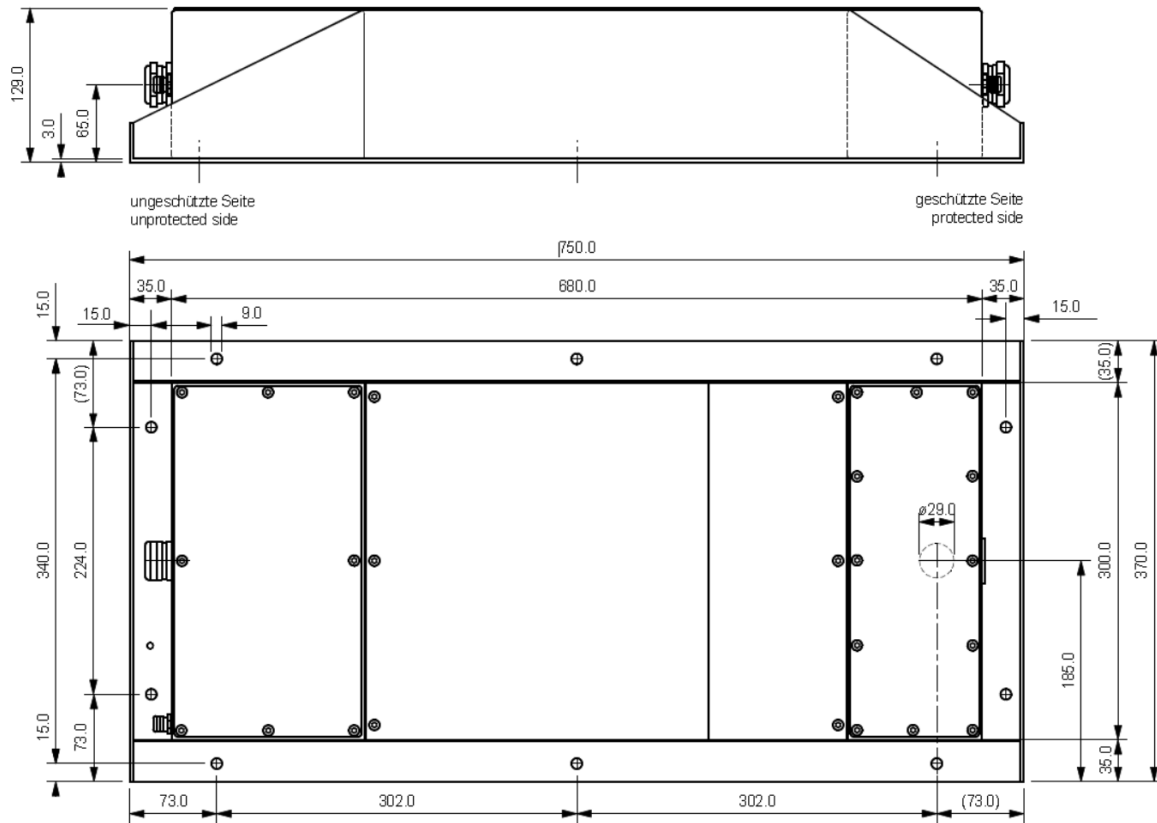

Installation Notes

- The EMP protector/filter has to be installed by electrically skilled personnel.
- The electrical wiring has to be done according to local regulations.
- The max. values stated in this datasheet must not be exceeded under any circumstances.
- PLP-series EMP protector/filter shall be permanently (not pluggable) connected to the grid.
- Residual current circuit breakers shall be used on the protected side of the surge protector, where they are protected from transient overvoltages.
- The EMP protector/filter may be directly installed to a Faraday cage as feed-through device. Otherwise the cabling on the protected side must be shielded.
- Do not use spacers between filter and Faraday cage.
- The screws of the covers shall be slightly lubricated for best performance.

Installation Instruction for mechanical shock protection

- The PLP-Series is approved for 3 bar shock protection according to Swiss Federal Office for Civil Protection (BABS, formerly BZS).
- Installation can be done by screws or direct welding to the Faraday cage. Usually installation using screws or bolts is more convenient.
- If screwed at least 4 pieces equally spaced screws M8 of class 8.8 including washer and spring washer shall be used. The torque shall be 83 Nm. Using more screws improves the electrical contact with the Faraday cage.
- Installation to a concrete wall requires at least 4 dowels approved by BABS. Each dowel shall have at least the capability to hold 2.3 kN.
- If welded at least 4 equally spaced fillet welds having a length of 50 mm shall be applied.

Ordering Information

Part.-Nr: **PLP-44041**
 Type-Nr.: USS-3x400/230V/40A/EMP-M



Warning
 High AC earth leakage current! Case of filter (Protective earth) must be solidly and permanently earthed. Always install protective earth first.

Contact

Meteolabor AG
 Hofstrasse 92
 CH-8620 Wetzikon
 Switzerland

Tel: +41 44 934 40 40
 E-Mail: info@meteolabor.ch
 Internet: www.meteolabor.ch

© by Meteolabor AG
 All rights reserved

Content may change without further notice 2023-07
 PLP-44041_e_V2023

EMP Surge Protector / Filter 4 lines (3L+N) 400 / 230 V, 100 A PLP-44101, PLP Series

Excellent protection of 4 lines (3L+N) 400/230V (50 / 60Hz) for power supply applications in fixed installations up to 100 A

Protection against HEMP / NEMP- and lightning overvoltages as well as against RF-interferences

Multi-stage protection / filter design providing very high transient energy absorption capability

Thermally monitored Surge Protection Devices with status signalization by potential free contact

Rigid stainless steel construction for direct installation to Faraday cage, approved for 3 bar blast shock according to BZS / BABS - Standard



Product

Meteolabor PLP-Series EMP Protector / Filter consist of Combinations of coarse and fine protection stages in combination with filtering components. This guarantees optimized protection of mission critical equipment against very fast transient overvoltages (e.g. NEMP / HEMP).

The PLP-Series is threat-level tested against EMP according to MIL-STD-188-125-1. For details see chapter "3 User Information"

Extremely high surge currents up to 100 kA (8 / 20µs) per line can be diverted.

For safety a capacitor discharge resistor is built in.

Applications

Meteolabor EMP-Protector / Filters protect sensitive electronics such as Computers, telecommunication equipment, controls etc. from damages due to NEMP / HEMP or lightning effects.

Radio frequency interferences are filtered by high quality low-pass filters. The filter is designed for fixed installation with permanent grounding.

Applications range from fixed military facilities (e.g. C⁴I facilities) to civilian or industrial projects requiring high reliability.

Technical Data PLP-44101

Nominal voltage U_N	3 x 400 / 230 V AC	50 / 60 Hz
Max. operating voltage U_c	3 x 460 / 255 V AC	50 / 60 Hz
Nominal current I_N	100 A	Effective at T_{amb} 40 °C
Max. surge current I_{Max}	100 kA	Each L / N → PE, shape 8 / 20 µs, T_{amb} 40°C, at least 1 pulse
Max. lightning impulse current I_{imp}	25 kA	Each L / N → PE, shape 10 / 350 µs, T_{amb} 40°C, at least 1 pulse
DC resistance	< 4 mΩ	Each L / N
Residual voltage surge	< 1 kV	L / N → PE, pulse 4 kV / 2 kA according to IEC 61000-4-5
Attenuation	> 80 dB	200 kHz – 1 GHz, 50 Ω - System
Withstanding Voltage	> 2000 V	Each L / N → PE, duration 2s
Withstanding Voltage	> 4000 V	Line to Line, duration 2s
50 Hz AC-leakage current	< 0.8 A	L → PE at U_N , 50 Hz
Combination Surge Protection Device	SPD Type 1 + 2	Fault indication by opening of a potential-free contact
Potential free contact	Normally closed	Max. 250 V AC, 0.5 A, open if at least one SPD has disconnected
Case material	Steel V 2 A	Central cover made from aluminium
Dimensions	1200x520x129 mm	External dimensions, Details see drawing
Weight	Approx. 74 kg	
Approval Number BZS	LS S07-911	Shock (3 bar) according BABS / BZS



Dimensions

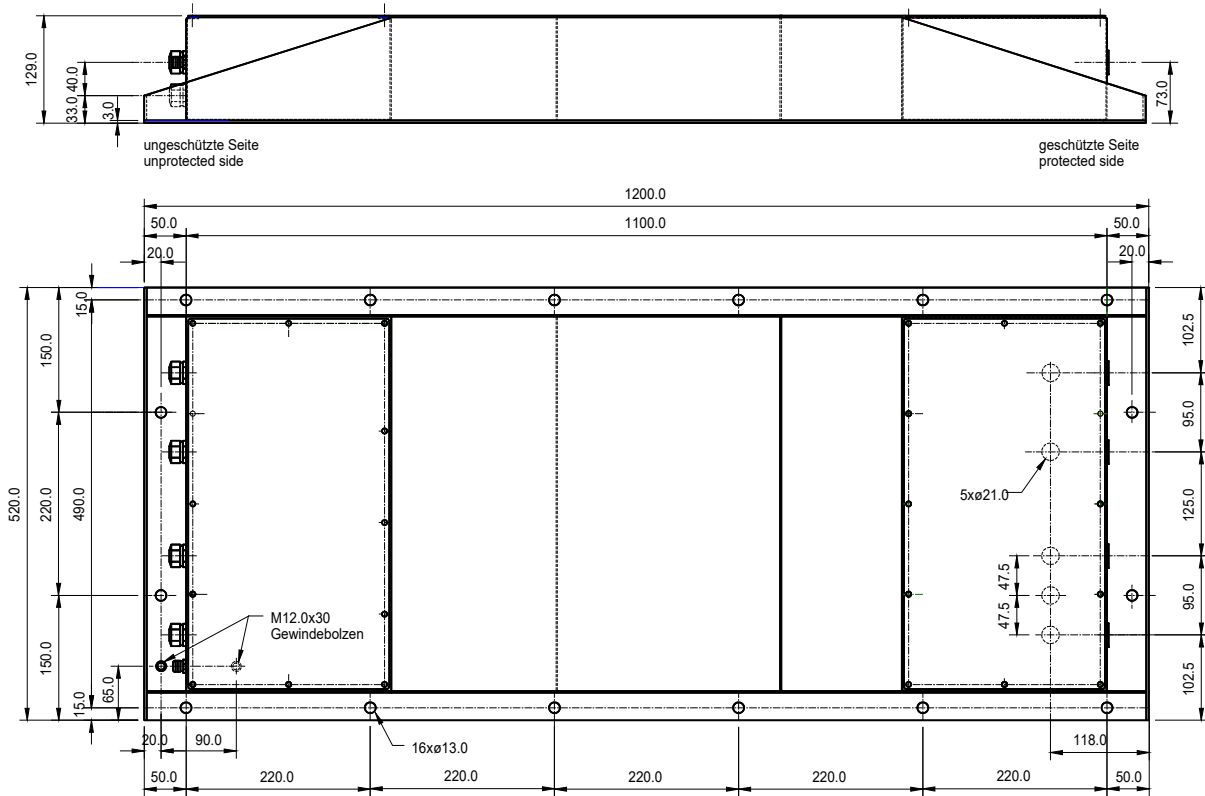

Installation Notes

- The EMP protector / filter has to be installed by electrically skilled personnel.
- The electrical wiring has to be done according to local regulations.
- The max. values stated in this datasheet must not be exceeded under any circumstances.
- PLP-series EMP protector / filter shall be permanently (not pluggable) connected to the grid.
- Residual current circuit breakers shall be used on the protected side of the surge protector, where they are protected from transient overvoltages.
- The EMP protector / filter may be directly installed to a Faraday cage as feed-through device. Otherwise the cabling on the protected side must be shielded.
- Do not use spacers between filter and Faraday cage.
- The screws of the covers shall be slightly lubricated for best performance.

Installation Instruction for mechanical shock protection

- The PLP-Series is approved for 3 bar shock protection according to Swiss Federal Office for Civil Protection (BABS, formerly BZS).
- Installation can be done by screws or direct welding to the Faraday cage. Usually installation using screws or bolts is more convenient.
- If screwed at least 6 pieces equally spaced screws M12 of class 8.8 including washer and spring washer shall be used. The torque shall be 83 Nm. Using more screws improves the electrical contact with the Faraday cage.
- Installation to a concrete wall requires at least 6 dowels approved by BABS. Each dowel shall have at least the capability to hold 3.4 kN.
- If welded at least 6 equally spaced fillet welds having a length of 50 mm shall be applied.

Ordering Information

Part.-Nr: **PLP-44101**
 Type-Nr.: USS-3x400/230V/100A/EMP-M

Warning
 High AC earth leakage current! Case of filter (Protective earth) must be solidly and permanently earthed. Always install protective earth first.

Contact

Meteolabor AG
 Hofstrasse 92
 CH-8620 Wetzikon
 Switzerland

Tel: +41 44 934 40 40
 E-Mail: info@meteolabor.ch
 Internet: www.meteolabor.ch

© by Meteolabor AG
 All rights reserved
 Content may change without further notice 2023-07
 PLP-44101_e_V2023

EMP Surge Protector / Filter 4 lines (3 L + N) 400 / 230 V, 125 A PLP-44121, PLP Series

Excellent protection of 4 lines (3 L + N) 400 / 230 V (50 / 60 Hz) for power supply applications in fixed installations up to max. 125 A per phase

Protection against HEMP / NEMP- and lightning overvoltages as well as against RF - interferences

Multi - stage protection / filter design providing very high transient energy absorption capability

Thermally monitored Surge Protection Devices with status signalization by potential free contact

Rigid stainless steel construction for direct installation to Faraday cage, approved for 3 bar blast shock according to BZS / BABS - Standard



Meteolabor PLP-Series EMP Protector / Filter consist of Combinations of coarse and fine protection stages in combination with filtering components. This guarantees optimized protection of mission critical equipment against very fast transient overvoltages (e.g. NEMP / HEMP).

The PLP-Series is threat-level tested against EMP according to MIL-STD-188-125-1, short pulse and intermediate pulse.

Extremely high surge currents up to 100 kA (8 / 20µs) per line can be diverted.

For safety a capacitor discharge resistor is built in.

Applications

Meteolabor EMP – Protector / Filters protect sensitive electronics such as Computers, telecommunication equipment, controls etc. from damages due to NEMP / HEMP or lightning effects.

Radio frequency interferences are filtered by high quality low - pass filters. The filter is designed for fixed installation with permanent grounding.

Applications range from fixed military facilities (e.g. C⁴I facilities) to civilian or industrial projects requiring high reliability.

Technical Data PLP-44121

Nominal voltage U_N	3 x 400 / 230 V AC	50 / 60 Hz
Max. operating voltage U_c	3 x 460 / 255 V AC	50 / 60 Hz
Nominal current I_N	125 A	Effective at T_{amb} 40°C
Max. surge current I_{Max}	100 kA	Each L / N → PE, shape 8 / 20 µs, T_{amb} 40°C, at least 1 pulse
Max. lightning impulse current I_{imp}	25 kA	Each L / N → PE, shape 10 / 350 µs, T_{amb} 40°C, at least 1 pulse
DC resistance	< 1.2 mΩ	Each L / N
Residual voltage HEMP-condition	< 50 V	L / N → PE, short pulse according MIL-STD-188-125-1
Residual voltage surge	< 1 kV	L / N → PE, pulse 4 kV / 2 kA according to IEC 61000-4-5
Attenuation	> 80 dB	200 kHz – 1 GHz, 50 Ω - System
50 Hz AC-leakage current	< 0.7 A	L → PE at U_N , 50 Hz
Combination Surge Protection Device	SPD Type 1 + 2	Fault indication by opening of a potential - free contact
Potential free contact	Normally closed	Max. 250 V AC, 0.5 A, open if at least one SPD has disconnected
Case material	Steel V 2 A	Central cover made from aluminium
Dimensions	1360x570x129 mm	External dimensions, Details see drawing
Weight	approx. 90 kg	
Approval Number BZS	LS S07-911	Shock (3 bar) according BABS / BZS



Dimensions

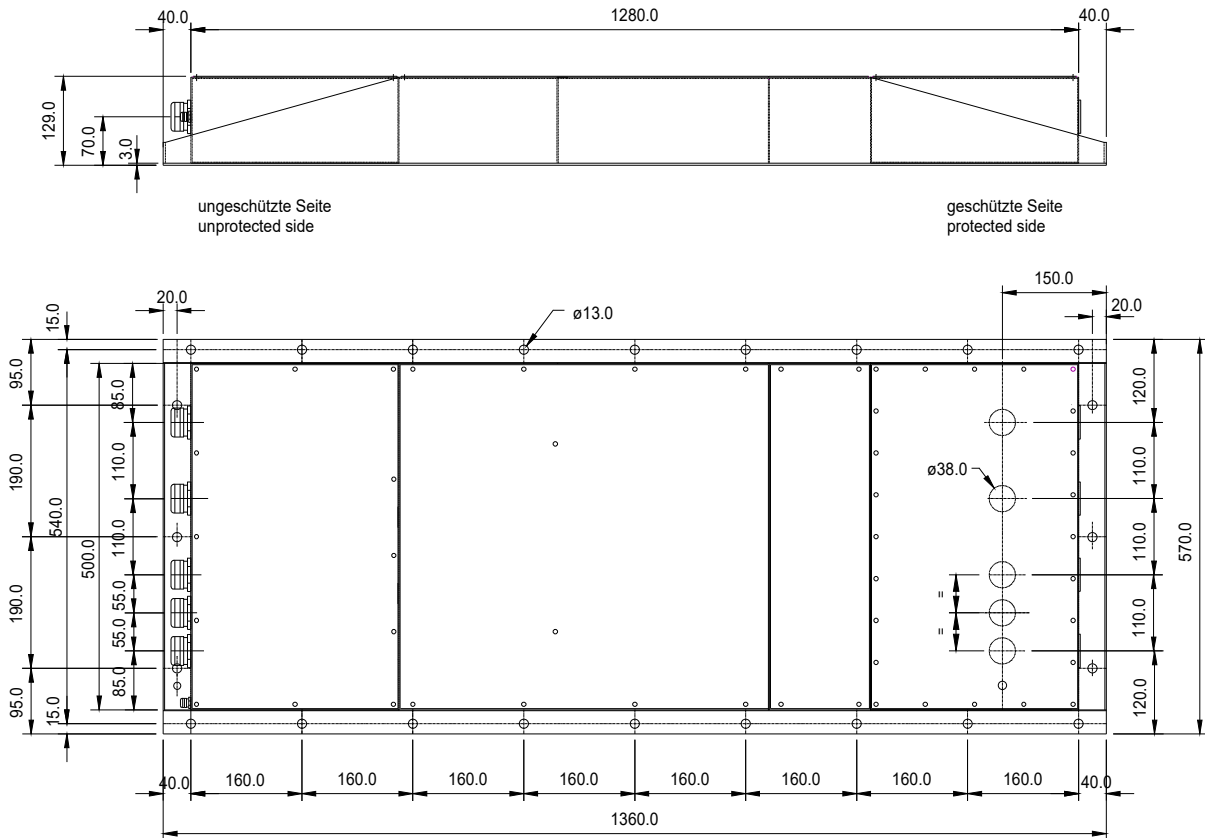

Installation Notes

- The EMP protector / filter has to be installed by electrically skilled personnel.
- The electrical wiring has to be done according to local regulations.
- The max. values stated in this datasheet must not be exceeded under any circumstances.
- PLP-series EMP protector / filter shall be permanently (not pluggable) connected to the grid.
- Residual current circuit breakers shall be used on the protected side of the surge protector, where they are protected from transient overvoltages.
- The EMP protector / filter may be directly installed to a Faraday cage as feed-through device. Otherwise the cabling on the protected side must be shielded.
- Do not use spacers between filter and Faraday cage.
- The screws of the covers shall be slightly lubricated for best performance.

Installation Instruction for mechanical shock protection

- The PLP-Series is approved for 3 bar shock protection according to Swiss Federal Office for Civil Protection (BABS, formerly BZS).
- Installation can be done by screws or direct welding to the Faraday cage. Usually installation using screws or bolts is more convenient.
- If screwed at least 6 pieces equally spaced screws M12 of class 8.8 including washer and spring washer shall be used. The torque shall be 83 Nm. Using more screws improves the electrical contact with the Faraday cage.
- Installation to a concrete wall requires at least 6 dowels approved by BABS. Each dowel shall have at least the capability to hold 4.3 kN.
- If welded at least 6 equally spaced fillet welds having a length of 50 mm shall be applied.

Ordering Information

Part.-Nr: **PLP-44121**
 Type-Nr.: USS-3x400/230V/125A/EMP-M



Warning

High AC earth leakage current! Case of filter (Protective earth) must be solidly and permanently earthed. Always install protective earth first.

Contact

Meteolabor AG
 Hofstrasse 92
 CH-8620 Wetzikon
 Switzerland

Tel: +41 44 934 40 40
 E-Mail: info@meteolabor.ch
 Internet: www.meteolabor.ch

© by Meteolabor AG
 All rights reserved

Content may change without further notice 2020-07
 PLP-44121_e_V2023

EMP Surge Protector / Filter 4 lines (3 L + N) 400 / 230 V, 200 A PLP-44201, PLP Series

Excellent protection of 4 lines (3 L + N) 400 / 230 V (50 / 60 Hz) for power supply applications in fixed installations up to 200 A

Protection against HEMP / NEMP- and lightning overvoltages as well as against RF - interferences

Multi - stage protection / filter design providing very high transient energy absorption capability

Thermally monitored Surge Protection Devices with status signalization by potential free contact

Rigid stainless steel construction for direct installation to Faraday cage, approved for 3 bar blast shock according to BZS / BABS - Standard



Meteolabor PLP-Series EMP Protector / Filter consist of Combinations of coarse and fine protection stages in combination with filtering components. This guarantees optimized protection of mission critical equipment against very fast transient overvoltages (e.g. NEMP / HEMP).

The PLP-Series is threat - level tested against EMP according to MIL-STD-188-125-1, short pulse and intermediate pulse.

Extremely high surge currents up to 100 kA (8 / 20µs) per line can be diverted.

For safety a capacitor discharge resistor is built in.

Applications

Meteolabor EMP-Protector / Filters protect sensitive electronics such as Computers, telecommunication equipment, controls etc. from damages due to NEMP / HEMP or lightning effects.

Radio frequency interferences are filtered by high quality low-pass filters. The filter is designed for fixed installation with permanent grounding.

Applications range from fixed military facilities (e.g. C⁴I facilities) to civilian or industrial projects requiring high reliability.

Technical Data PLP-44201

Nominal voltage U_N	3 x 400 / 230 V AC	50 / 60 Hz
Max. operating voltage U_c	3 x 460 / 255 V AC	50 / 60 Hz
Nominal current I_N	200 A	Effective at T_{amb} 40°C
Max. surge current I_{Max}	100 kA	Each L / N → PE, shape 8 / 20 µs, T_{amb} 40°C, at least 1 pulse
Max. lightning impulse current I_{imp}	25 kA	Each L / N → PE, shape 10 / 350 µs, T_{amb} 40°C, at least 1 pulse
DC resistance	< 1.2 mΩ	Each L / N
Residual voltage HEMP-condition	< 50 V	L / N → PE, short pulse according MIL-STD-188-125-1
Residual voltage surge	< 1 kV	L / N → PE, pulse 4 kV / 2 kA according to IEC 61000-4-5
Attenuation	> 80 dB	200 kHz – 1 GHz, 50 Ω - System
50 Hz AC-leakage current	< 0.7 A	L → PE at U_N , 50 Hz
Combination Surge Protection Device	SPD Type 1 + 2	Fault indication by opening of a potential - free contact
Potential free contact	Normally closed	Max. 250 V AC, 0.5 A, open if at least one SPD has disconnected
Case material	Steel V 2 A	Central cover made from aluminium
Dimensions	1360x570x129 mm	External dimensions, Details see drawing
Weight	approx. 90 kg	
Approval Number BZS	LS S07-911	Shock (3 bar) according BABS / BZS



Dimensions

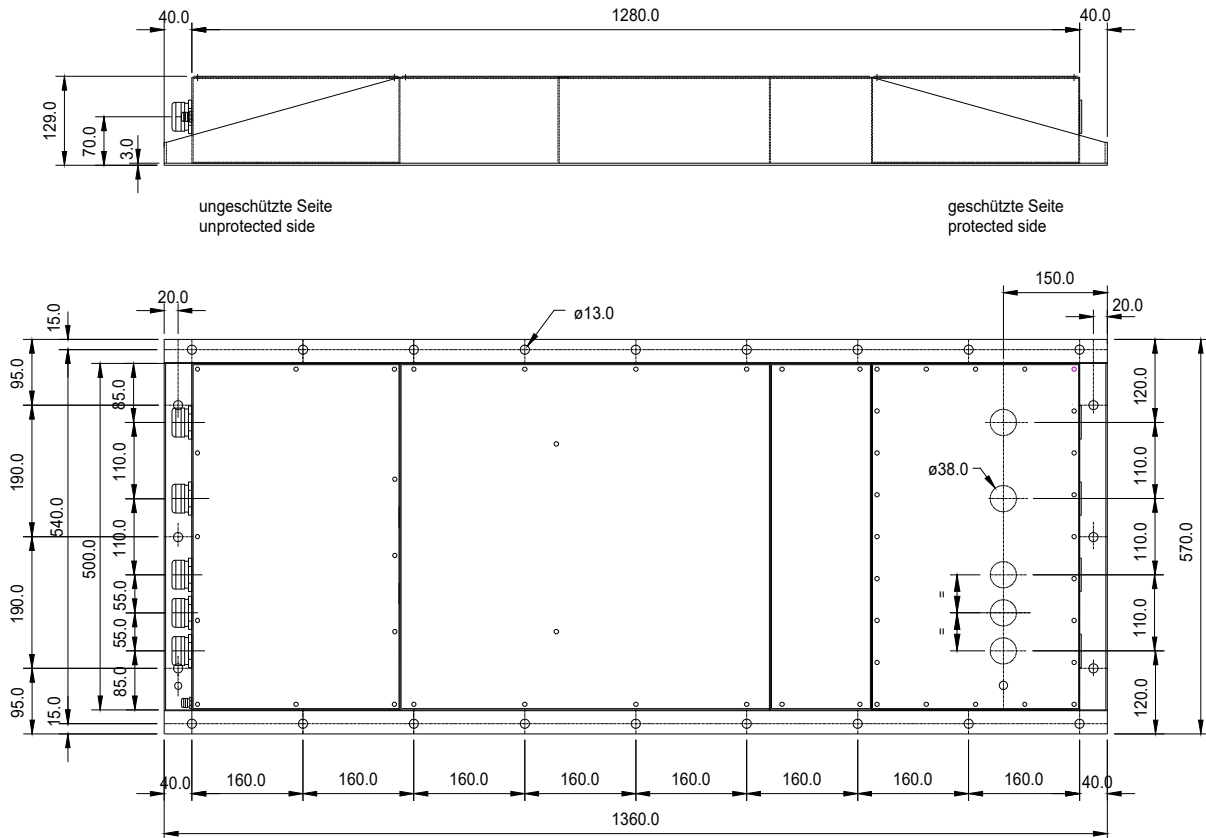

Installation Notes

- The EMP protector / filter has to be installed by electrically skilled personnel.
- The electrical wiring has to be done according to local regulations.
- The max. values stated in this datasheet must not be exceeded under any circumstances.
- PLP-series EMP protector / filter shall be permanently (not pluggable) connected to the grid.
- Residual current circuit breakers shall be used on the protected side of the surge protector, where they are protected from transient overvoltages.
- The EMP protector / filter may be directly installed to a Faraday cage as feed - through device. Otherwise the cabling on the protected side must be shielded.
- Do not use spacers between filter and Faraday cage.
- The screws of the covers shall be slightly lubricated for best performance.

Installation Instruction for Mechanical Shock Protection

- The PLP-Series is approved for 3 bar shock protection according to Swiss Federal Office for Civil Protection (BABS, formerly BZS).
- Installation can be done by screws or direct welding to the Faraday cage. Usually installation using screws or bolts is more convenient.
- If screwed at least 6 pieces equally spaced screws M12 of class 8.8 including washer and spring washer shall be used. The torque shall be 83 Nm. Using more screws improves the electrical contact with the Faraday cage.
- Installation to a concrete wall requires at least 6 dowels approved by BABS. Each dowel shall have at least the capability to hold 4.3 kN.
- If welded at least 6 equally spaced fillet welds having a length of 50 mm shall be applied.

Ordering Information

Part.-Nr: **PLP-44201**
 Type-Nr.: USS-3x400/230V/200A/EMP-M

Warning
 High AC earth leakage current! Case of filter (Protective earth) must be solidly and permanently earthed. Always install protective earth first.

Contact

Meteolabor AG
 Hofstrasse 92
 CH-8620 Wetzikon
 Switzerland

Tel: +41 44 934 40 40
 E-Mail: info@meteolabor.ch
 Internet: www.meteolabor.ch

© by Meteolabor AG
 All rights reserved
 Content may change without further notice 2023-07
 PLP-44201_e_V2027

EMP Surge Protector / Filter 4 lines (3L+N) 400 / 230 V, 400 A PLP-44401, PLP Series

Excellent protection of 4 lines (3L+N) 400 / 230 V (50 / 60 Hz) for power supply applications in fixed installations up to 400 A per phase

Protection against HEMP / NEMP- and lightning overvoltages as well as against RF-interferences

Multi-stage protection / filter design providing very high transient energy absorption capability

Thermally monitored Surge Protection Devices with status signalization by potential free contact

Rigid stainless steel construction for direct installation to Faraday cage, approved for 3 bar blast shock according to BZS / BABS - Standard



Product

Meteolabor PLP-Series EMP Protector / Filter consist of Combinations of coarse and fine protection stages in combination with filtering components. This guarantees optimized protection of mission critical equipment against very fast transient overvoltages (e.g. NEMP / HEMP).

The PLP-Series is threat-level tested against EMP according to MIL-STD-188-125-1. For details see chapter "3 User Information"

Extremely high surge currents up to 100 kA (8 / 20µs) per line can be diverted.

For safety a capacitor discharge resistor is built in.

Applications

Meteolabor EMP-Protector / Filters protect sensitive electronics such as Computers, telecommunication equipment, controls etc. from damages due to NEMP / HEMP or lightning effects.

Radio frequency interferences are filtered by high quality low-pass filters. The filter is designed for fixed installation with permanent grounding.

Applications range from fixed military facilities (e.g. C⁴I facilities) to civilian or industrial projects requiring high reliability.

Technical Data PLP-44401

Nominal voltage U_N	3 x 400 / 230 V AC	50 / 60 Hz
Max. operating voltage U_c	3 x 460 / 255 V AC	50 / 60 Hz
Nominal current I_N	400 A	Effective at T_{amb} 40 °C
Max. surge current I_{Max}	100 kA	Each L / N → PE, shape 8/20 µs, T_{amb} 40°C, at least 1 pulse
Max. lightning impulse current I_{Imp}	25 kA	Each L / N → PE, shape 10/350 µs, T_{amb} 40°C, at least 1 pulse
DC resistance	< 0.65 mΩ	Each L / N
Residual voltage surge	< 1 kV	L / N → PE, pulse 4 kV / 2 kA according to IEC 61000-4-5
Attenuation	> 80 dB	200 kHz – 1 GHz, 50 Ω - System
50 Hz AC-leakage current	< 2.4 A	L → PE at U_N , 50 Hz
Combination Surge Protection Device	SPD Type 1 + 2	Fault indication by opening of a potential-free contact
Potential free contact	Normally closed	Max. 250 V AC, 0.5 A, open if at least one SPD has disconnected
Case material	Steel V 2 A	Central cover made from aluminium
Dimensions	1360x570x129 mm	External dimensions single case only, details see drawing
Weight	Approx. 180 kg	Total (2 x 90 kg)
Approval Number BZS	LS S07-911	Shock (3 bar) according BABS / BZS



Dimensions (Single case of totally two cases)

Note: The 400 A EMP-Protection consists of 2 identical cases (one for L1 + L2 and one for L3 + N)

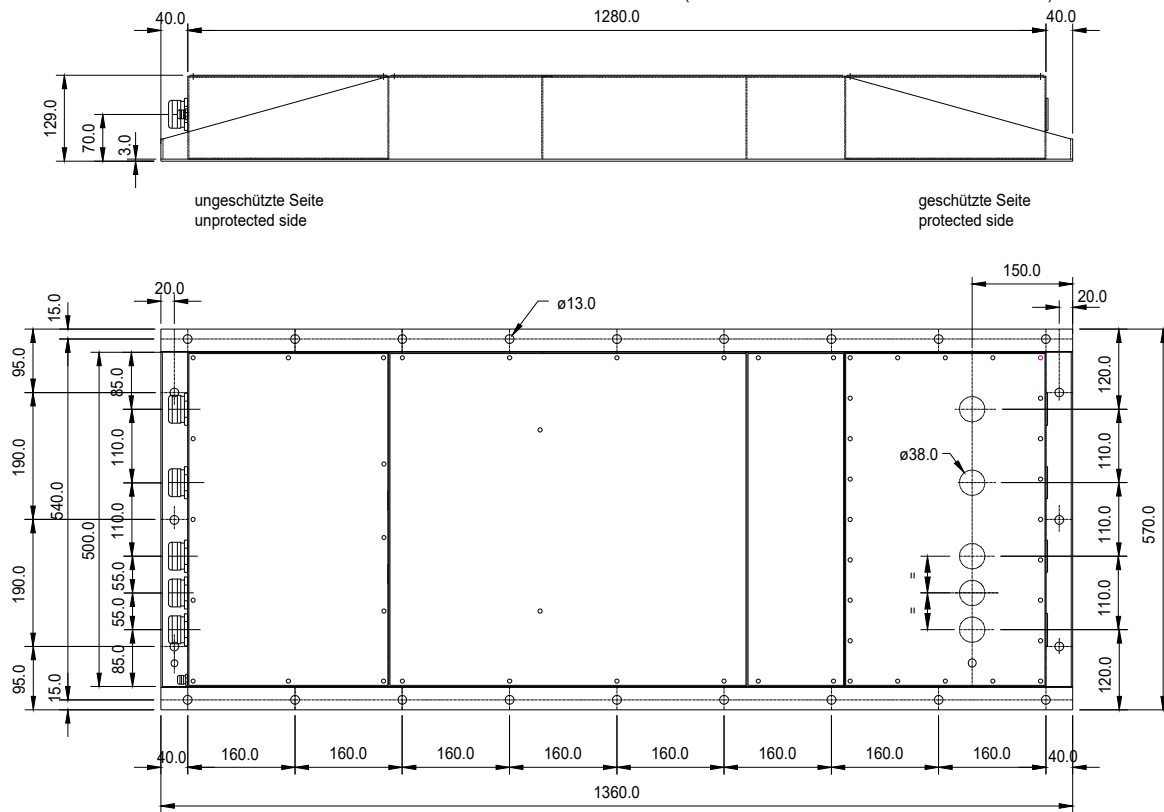

Installation Notes

- The EMP protector / filter has to be installed by electrically skilled personnel.
- The electrical wiring has to be done according to local regulations.
- The max. values stated in this datasheet must not be exceeded under any circumstances.
- PLP-series EMP protector / filter shall be permanently (not pluggable) connected to the grid.
- Residual current circuit breakers shall be used on the protected side of the surge protector, where they are protected from transient overvoltages.
- The EMP protector / filter may be directly installed to a Faraday cage as feed-through device. Otherwise the cabling on the protected side must be shielded.
- Do not use spacers between filter and Faraday cage.
- The screws of the covers shall be slightly lubricated for best performance.

Installation Instruction for Mechanical Shock Protection

- The PLP-Series is approved for 3 bar shock protection according to Swiss Federal Office for Civil Protection (BABS, formerly BZS).
- Installation can be done by screws or direct welding to the Faraday cage. Usually installation using screws or bolts is more convenient.
- If screwed at least 6 pieces equally spaced screws M12 of class 8.8 including washer and spring washer shall be used. The torque shall be 83 Nm. Using more screws improves the electrical contact with the Faraday cage.
- Installation to a concrete wall requires at least 6 dowels approved by BABS. Each dowel shall have at least the capability to hold 4.3 kN.
- If welded at least 6 equally spaced fillet welds having a length of 50 mm shall be applied.

Ordering Information

Part.-Nr: **PLP-44401**
 Type-Nr.: USS-3x400/230V/400A/EMP-M

Warning
 High AC earth leakage current! Case of filter (Protective earth) must be solidly and permanently earthed. Always install protective earth first.

Contact

Meteolabor AG
 Hofstrasse 92
 CH-8620 Wetzikon
 Switzerland

Tel: +41 44 934 40 40
 E-Mail: info@meteolabor.ch
 Internet: www.meteolabor.com

© by Meteolabor AG
 All rights reserved
 Content may change without further notice 2023-07
 PLP-44401_e_V2023

EMP Surge Protector / Filter 2 lines (L + N) 230 V, 400 A PLP-44421, PLP Series

Excellent protection of 2 lines (L + N) /230 V (50 / 60Hz) for power supply applications in fixed installations up to 400 A

Protection against HEMP / NEMP- and lightning overvoltages as well as against RF - interferences

Multi-stage protection / filter design providing very high transient energy absorption capability

Thermally monitored Surge Protection Devices with status signalization by potential free contact

Rigid stainless steel construction for direct installation to Faraday cage, approved for 3 bar blast shock according to BZS / BABS - Standard



Meteolabor PLP-Series EMP Protector / Filter consist of Combinations of coarse and fine protection stages in combination with filtering components. This guarantees optimized protection of mission critical equipment against very fast transient overvoltages (e.g. NEMP / HEMP).

The PLP-Series is threat-level tested against EMP according to MIL-STD-188-125-1, short pulse and intermediate pulse.

Extremely high surge currents up to 100 kA (8 / 20µs) per line can be diverted.

For safety a capacitor discharge resistor is built in.

Applications

Meteolabor EMP – Protector / Filters protect sensitive electronics such as Computers, telecommunication equipment, controls etc. from damages due to NEMP / HEMP or lightning effects.

Radio frequency interferences are filtered by high quality low-pass filters. The filter is designed for fixed installation with permanent grounding.

Applications range from fixed military facilities (e.g. C⁴I facilities) to civilian or industrial projects requiring high reliability.

Technical Data PLP-44421

Nominal voltage U_N	230 V AC	50 / 60 Hz
Max. operating voltage U_c	255 V AC	50 / 60 Hz
Nominal current I_N	400 A	Effective at T_{amb} 40°C
Max. surge current I_{Max}	100 kA	Each L / N → PE, shape 8 / 20 µs, T_{amb} 40°C, at least 1 pulse
Max. lightning impulse current I_{imp}	25 kA	Each L / N → PE, shape 10 / 350 µs, T_{amb} 40°C, at least 1 pulse
DC resistance	< 0.65 mΩ	Each L / N
Residual voltage HEMP-condition	< 50 V	L / N → PE, short pulse according MIL-STD-188-125-1
Residual voltage surge	< 1 kV	L/N → PE, pulse 4 kV / 2 kA according to IEC 61000-4-5
Attenuation	> 80 dB	200 kHz – 1 GHz, 50 Ω - System
50 Hz AC-leakage current	< 2.4 A	L → PE at U_N , 50 Hz
Combination Surge Protection Device	SPD Type 1 + 2	Fault indication by opening of a potential-free contact
Potential free contact	Normally closed	Max. 250 V AC, 0.5 A, open if at least one SPD has disconnected
Case material	Steel V 2 A	Central cover made from aluminium
Dimensions	1360x570x129 mm	External dimensions single case only, details see drawing
Weight	Approx. 90 kg	
Approval Number BZS	LS S07-911	Shock (3 bar) according BABS / BZS



Dimensions (in mm)

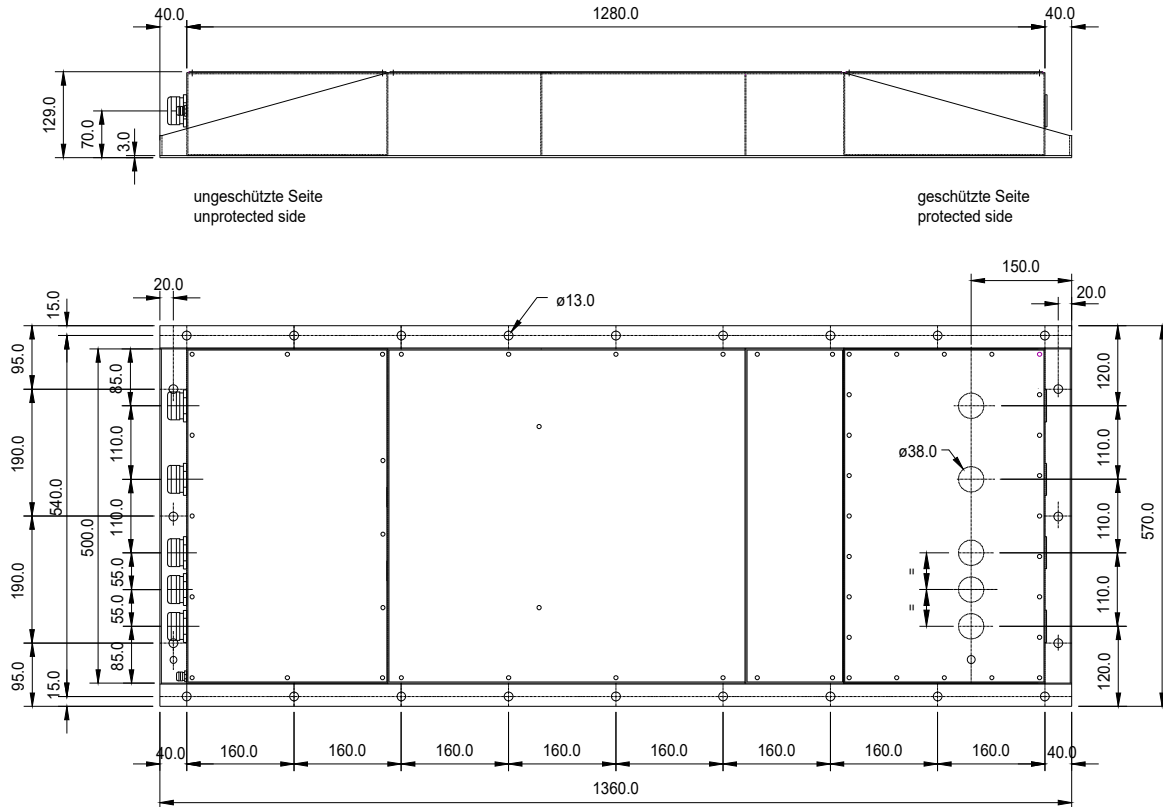

Installation Notes

- The EMP protector / filter has to be installed by electrically skilled personnel.
- The electrical wiring has to be done according to local regulations.
- The max. values stated in this datasheet must not be exceeded under any circumstances.
- PLP-series EMP protector / filter shall be permanently (not pluggable) connected to the grid.
- Residual current circuit breakers shall be used on the protected side of the surge protector, where they are protected from transient overvoltages.
- The EMP protector / filter may be directly installed to a Faraday cage as feed-through device. Otherwise the cabling on the protected side must be shielded.
- Do not use spacers between filter and Faraday cage.
- The screws of the covers shall be slightly lubricated for best performance.

Installation Instruction for Mechanical Shock Protection

- The PLP-Series is approved for 3 bar shock protection according to Swiss Federal Office for Civil Protection (BABS, formerly BZS).
- Installation can be done by screws or direct welding to the Faraday cage. Usually installation using screws or bolts is more convenient.
- If screwed at least 6 pieces equally spaced screws M12 of class 8.8 including washer and spring washer shall be used. The torque shall be 83 Nm. Using more screws improves the electrical contact with the Faraday cage.
- Installation to a concrete wall requires at least 6 dowels approved by BABS. Each dowel shall have at least the capability to hold 4.3 kN.
- If welded at least 6 equally spaced fillet welds having a length of 50 mm shall be applied.

Ordering Information

Part.-Nr: **PLP-44421**
 Type-Nr.: USS-2x230V/400A/EMP-M

Warning
 High AC earth leakage current! Case of filter (Protective earth) must be solidly and permanently earthed. Always install protective earth first.

Contact

Meteolabor AG
 Hofstrasse 92
 CH-8620 Wetzikon
 Switzerland

Tel: +41 44 934 40 40
 E-Mail: info@meteolabor.ch
 Internet: www.meteolabor.ch

© by Meteolabor AG
 All rights reserved
 Content may change without further notice 2023-07
 PLP-44421_e_V2023

EMP Surge Protector / Filter 4 lines (3L + N) 400 / 230 V, 800 A PLP-44801, PLP Series

Excellent protection of 4 lines (3L + N) 400 / 230 V (50 / 60 Hz) for power supply applications in fixed installations up to 800 A per phase

Protection against HEMP / NEMP- and lightning overvoltages as well as against RF-interferences

Multi-stage protection / filter design providing very high transient energy absorption capability

Thermally monitored Surge Protection Devices with status signalization by potential free contact

Rigid stainless steel construction for direct installation to Faraday cage, approved for 3 bar blast shock according to BZS / BABS - Standard



Product

Meteolabor PLP-Series EMP Protector / Filter consist of Combinations of coarse and fine protection stages in combination with filtering components. This guarantees optimized protection of mission critical equipment against very fast transient overvoltages (e.g. NEMP / HEMP).

The PLP-Series is threat-level tested against EMP according to MIL-STD-188-125-1. For details see chapter "3 User Information"

Extremely high surge currents up to 100 kA (8 / 20µs) per line can be diverted.

For safety a capacitor discharge resistor is built in.

Applications

Meteolabor EMP-Protector / Filters protect sensitive electronics such as Computers, telecommunication equipment, controls etc. from damages due to NEMP / HEMP or lightning effects.

Radio frequency interferences are filtered by high quality low-pass filters. The filter is designed for fixed installation with permanent grounding.

Applications range from fixed military facilities (e.g. C⁴I facilities) to civilian or industrial projects requiring high reliability.

Technical Data PLP-44801

Nominal voltage U_N	3 x 400 / 230 V AC	50 / 60 Hz
Max. operating voltage U_c	3 x 460 / 255 V AC	50 / 60 Hz
Nominal current I_N	800 A	Effective at T_{amb} 40 °C
Max. surge current I_{Max}	100 kA	Each L / N → PE, shape 8 / 20 µs, T_{amb} 40°C, at least 1 pulse
Max. lightning impulse current I_{Imp}	25kA	Each L / N → PE, shape 10 / 350 µs, T_{amb} 40°C, at least 1 pulse
DC resistance	< 0.3 mΩ	Each L / N
Residual voltage surge	< 1 kV	L/N → PE, pulse 4 kV / 2 kA according to IEC 61000-4-5
Attenuation	> 80 dB	200 kHz – 1 GHz, 50 Ω - System
50 Hz AC-leakage current	< 3 A	L → PE at U_N , 50 Hz
Combination Surge Protection Device	SPD Type 1 + 2	Fault indication by opening of a potential-free contact
Potential free contact	Normally closed	Max. 250 V AC, 0.5 A, open if at least one SPD has disconnected
Case material	Stahl V 2 A	Central cover made from aluminium
Dimensions	1360x570x129 mm	External dimensions per phase/neutral, Details see drawing
Weight	Approx. 360 kg	Total (4 x 90 kg)
Approval Number BZS	LS S07-911	Shock (3 bar) according BABS / BZS



Dimensions (Single case of four cases)

Note: The 800A EMP-Protection consists of 4 identical cases (one for each phase / neutral)

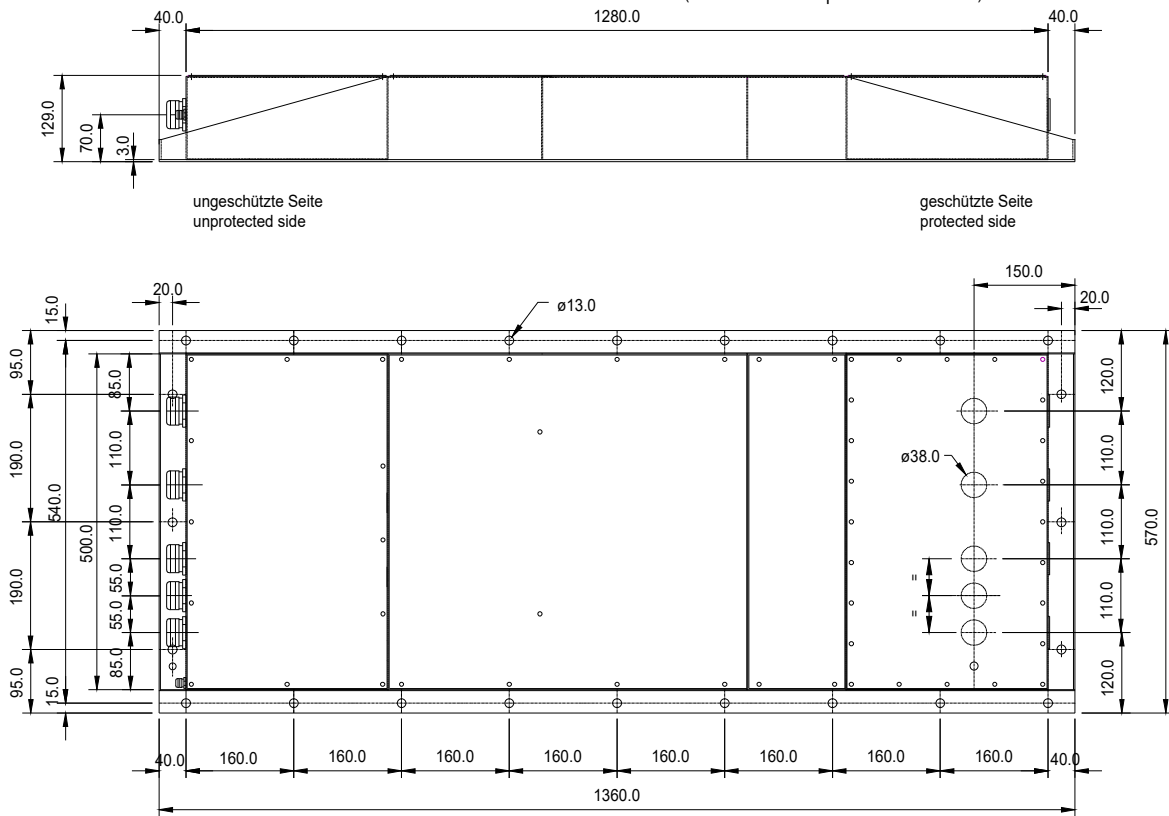

Installation Notes

- The EMP protector / filter has to be installed by electrically skilled personnel.
- The electrical wiring has to be done according to local regulations.
- The max. values stated in this datasheet must not be exceeded under any circumstances.
- PLP-series EMP protector / filter shall be permanently (not pluggable) connected to the grid.
- Residual current circuit breakers shall be used on the protected side of the surge protector, where they are protected from transient overvoltages.
- The EMP protector / filter may be directly installed to a Faraday cage as feed-through device. Otherwise the cabling on the protected side must be shielded.
- Do not use spacers between filter and Faraday cage.
- The screws of the covers shall be slightly lubricated for best performance.

Installation Instruction for Mechanical Shock Protection

- The PLP-Series is approved for 3 bar shock protection according to Swiss Federal Office for Civil Protection (BABS, formerly BZS).
- Installation can be done by screws or direct welding to the Faraday cage. Usually installation using screws or bolts is more convenient.
- If screwed at least 6 pieces equally spaced screws M12 of class 8.8 including washer and spring washer shall be used. The torque shall be 83 Nm. Using more screws improves the electrical contact with the Faraday cage.
- Installation to a concrete wall requires at least 6 dowels approved by BABS. Each dowel shall have at least the capability to hold 4.3 kN.
- If welded at least 6 equally spaced fillet welds having a length of 50 mm shall be applied.

Ordering Information

Part.-Nr: **PLP-44801**
 Type-Nr.: USS-3x400/230V/800A/EMP-M

Warning
 High AC earth leakage current! Case of filter (Protective earth) must be solidly and permanently earthed. Always install protective earth first.

Contact

Meteolabor AG
 Hofstrasse 92
 CH-8620 Wetzikon
 Switzerland

Tel: +41 44 934 40 40
 E-Mail: info@meteolabor.ch
 Internet: www.meteolabor.ch

© by Meteolabor AG
 All rights reserved

Content may change without further notice 2023-07
 PLP-44801_e_V2023

EMP Surge Protector / Filter 4 lines (3L+N) 400 / 230 V, 40 A PLP-FC-400-40-2, PLP-FC Series

Excellent protection of 4 lines (3L+N) 400/230V (50 / 60Hz) for power supply applications.

Fully compliant to MIL-STD-188-125-1

Protection against HEMP / NEMP- and lightning overvoltages as well as against RF-interferences

Multi-stage protection / filter design providing very high transient energy absorption capability

Thermally monitored Surge Protection Devices with status signalization by potential free contact

Rigid stainless steel for direct installation to Faraday cage. Approved for 3 bar blast shock.



Product

Meteolabor PLP-Series EMP Protector / Filter consist of Combinations of coarse and fine protection stages in combination with filtering components. This guarantees optimized protection of mission critical equipment against very fast transient overvoltages (e.g. NEMP / HEMP).

The PLP-FC Series is **fully compliant to MIL-STD-188-125-1**. For details see chapter "3 User Information"

Extremely high surge currents up to 100 kA (8 / 20µs) per line can be diverted.

For safety a capacitor discharge resistor is built in.

Applications

Meteolabor EMP-Protector / Filters protect sensitive electronics such as Computers, telecommunication equipment, controls etc. from damages due to NEMP / HEMP or lightning effects.

Radio frequency interferences are filtered by high quality low-pass filters. The filter is designed for fixed installation with permanent grounding.

Applications range from fixed military facilities (e.g. C⁴I facilities) to civilian or industrial projects requiring high reliability.

Technical Data PLP-FC-400-40-2

Nominal voltage U_N	3 x 400 / 230 V AC	50 / 60 Hz
Max. operating voltage U_c	3 x 460 / 255 V AC	50 / 60 Hz
Nominal current I_N	40 A	Effective at $T_{amb} 40\text{ °C}$
Max. surge current I_{Max}	100 kA	Each L / N → PE, shape 8 / 20 µs, $T_{amb} 40\text{ °C}$, at least 1 pulse
Max. lightning impulse current I_{imp}	25 kA	Each L / N → PE, shape 10 / 350 µs, $T_{amb} 40\text{ °C}$, at least 1 pulse
DC resistance	< 8 mΩ	Each L / N
Residual current MIL-STD-188-125-1	< 10 A	If a full E1 is applied as input signal
Residual voltage surge	< 1.6 kV	L / N → PE, pulse 4 kV / 2 kA according to IEC 61000-4-5
Attenuation	> 80 dB	200 kHz – 2.9 GHz, 50 Ω - System
50 Hz AC-leakage current	< 1.7 A	L → PE at U_N , 50 Hz
Combination Surge Protection Device	SPD Type 1 + 2 + 3	Fault indication by opening of a potential-free contact
Potential free contact	Normally closed	Max. 250 V AC, 0.5 A, open if at least one SPD has disconnected
Case material	Steel V 2 A	Complete case St 1.4301
Dimensions	750 x 370 x 129 mm	External dimensions, Details see drawing
Weight	27 kg	
Approval Number BZS	LS SE 19-907	Shock (3 bar) according BABS / BZS



Dimensions

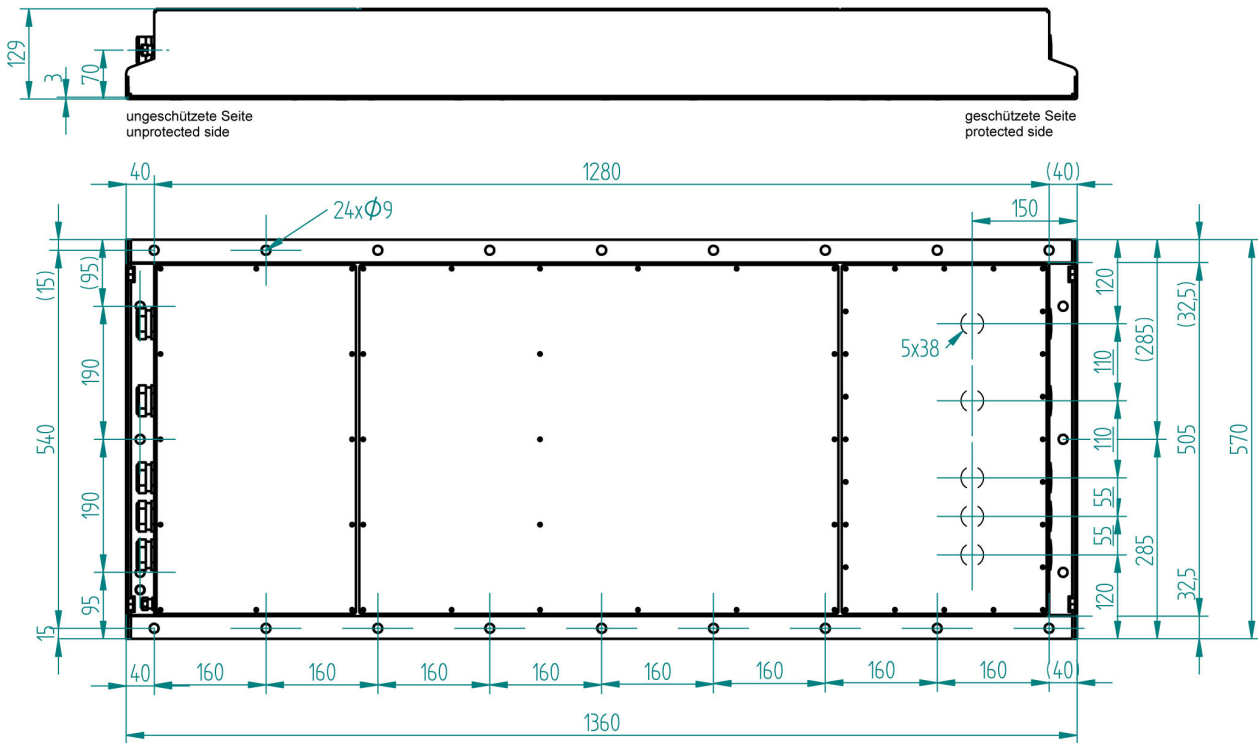

Installation Notes

- The EMP protector / filter has to be installed by electrically skilled personnel.
- The electrical wiring has to be done according to local regulations.
- The max. values stated in this datasheet must not be exceeded under any circumstances.
- PLP-series EMP protector / filter shall be permanently (not pluggable) connected to the grid.
- Residual current circuit breakers shall be used on the protected side of the surge protector, where they are protected from transient overvoltages.
- The EMP protector / filter may be directly installed to a Faraday cage as feed-through device. Otherwise the cabling on the protected side must be shielded.
- Do not use spacers between filter and Faraday cage.
- The screws of the covers shall be slightly lubricated for best performance.

Installation Instruction for mechanical shock protection

- The PLP-Series is approved for 3 bar shock protection according to Swiss Federal Office for Civil Protection BABS.
- Installation can be done by screws or direct welding to the Faraday cage. Usually installation using screws or bolts is more convenient.
- If screwed at least 6 pieces equally spaced screws M8 of class 8.8 including washer and spring washer shall be used. The torque shall be 25 Nm. Using more than 6 screws improves the electrical contact with the Faraday cage.
- Installation to a concrete wall requires at least 6 dowels. Each dowel shall have at least the capability to hold 2.2 kN.
- If welded at least 8 equally spaced fillet welds having a length of 50 mm shall be applied.

Ordering Information

Part.-Nr: **PLP-FC-400-40-2**
 Type-Nr.: USS-3x400/230V/40A-MIL-STD

Warning
 High AC earth leakage current! Case of filter (Protective earth) must be solidly and permanently earthed. Always install protective earth first.

Contact

Meteolabor AG
 Hofstrasse 92
 CH-8620 Wetzikon
 Switzerland

Tel: +41 44 934 40 40
 E-Mail: info@meteolabor.ch
 Internet: www.meteolabor.ch

© by Meteolabor AG
 All rights reserved
 Content may change without further notice 2023-07
 PLP-FC-400-40-2_e_V2027

EMP Surge Protector / Filter 4 lines (3L+N) 400 / 230 V, 100 A PLP-FC-400-100, PLP-FC Series

Excellent protection of 4 lines (3L+N) 400/230V (50 / 60Hz) for power supply applications.

Fully compliant to MIL-STD-188-125-1

Protection against HEMP / NEMP- and lightning overvoltages as well as against RF-interferences

Multi-stage protection / filter design providing very high transient energy absorption capability

Thermally monitored Surge Protection Devices with status signalization by potential free contact

Rigid stainless steel for direct installation to Faraday cage. Approved for 3 bar blast shock.



Product

Meteolabor PLP-Series EMP Protector / Filter consist of Combinations of coarse and fine protection stages in combination with filtering components. This guarantees optimized protection of mission critical equipment against very fast transient overvoltages (e.g. NEMP / HEMP).

The PLP-FC Series is **fully compliant to MIL-STD-188-125-1**. For details see chapter "3 User Information"

Extremely high surge currents up to 100 kA (8 / 20µs) per line can be diverted.

For safety a capacitor discharge resistor is built in.

Applications

Meteolabor EMP-Protector / Filters protect sensitive electronics such as Computers, telecommunication equipment, controls etc. from damages due to NEMP / HEMP or lightning effects.

Radio frequency interferences are filtered by high quality low-pass filters. The filter is designed for fixed installation with permanent grounding.

Applications range from fixed military facilities (e.g. C⁴I facilities) to civilian or industrial projects requiring high reliability.

Technical Data PLP-FC-400-100

Nominal voltage U_N	3 x 400 / 230 V AC	50 / 60 Hz
Max. operating voltage U_c	3 x 460 / 255 V AC	50 / 60 Hz
Nominal current I_N	100 A	Effective at $T_{amb} 40\text{ °C}$
Max. surge current I_{Max}	100 kA	Each L / N → PE, shape 8 / 20 µs, $T_{amb} 40\text{ °C}$, at least 1 pulse
Max. lightning impulse current I_{imp}	25 kA	Each L / N → PE, shape 10 / 350 µs, $T_{amb} 40\text{ °C}$, at least 1 pulse
DC resistance	< 3.3 mΩ	Each L / N
Residual current MIL-STD-188-125-1	< 10 A	If a full E1 is applied as input signal
Residual voltage surge	< 1.6 kV	L / N → PE, pulse 4 kV / 2 kA according to IEC 61000-4-5
Attenuation	> 80 dB	100 kHz – 2.9 GHz, 50 Ω - System
50 Hz AC-leakage current	< 1.2 A	L → PE at U_N , 50 Hz
Combination Surge Protection Device	SPD Type 1 + 2 + 3	Fault indication by opening of a potential-free contact
Potential free contact	Normally closed	Max. 250 V AC, 0.5 A, open if at least one SPD has disconnected
Case material	Steel V 2 A	Complete case St 1.4301
Dimensions	1360x570x129 mm	External dimensions, Details see drawing
Weight	82 kg	
Approval Number BZS	LS SE 19-907	Shock (3 bar) according BABS / BZS

Dimensions

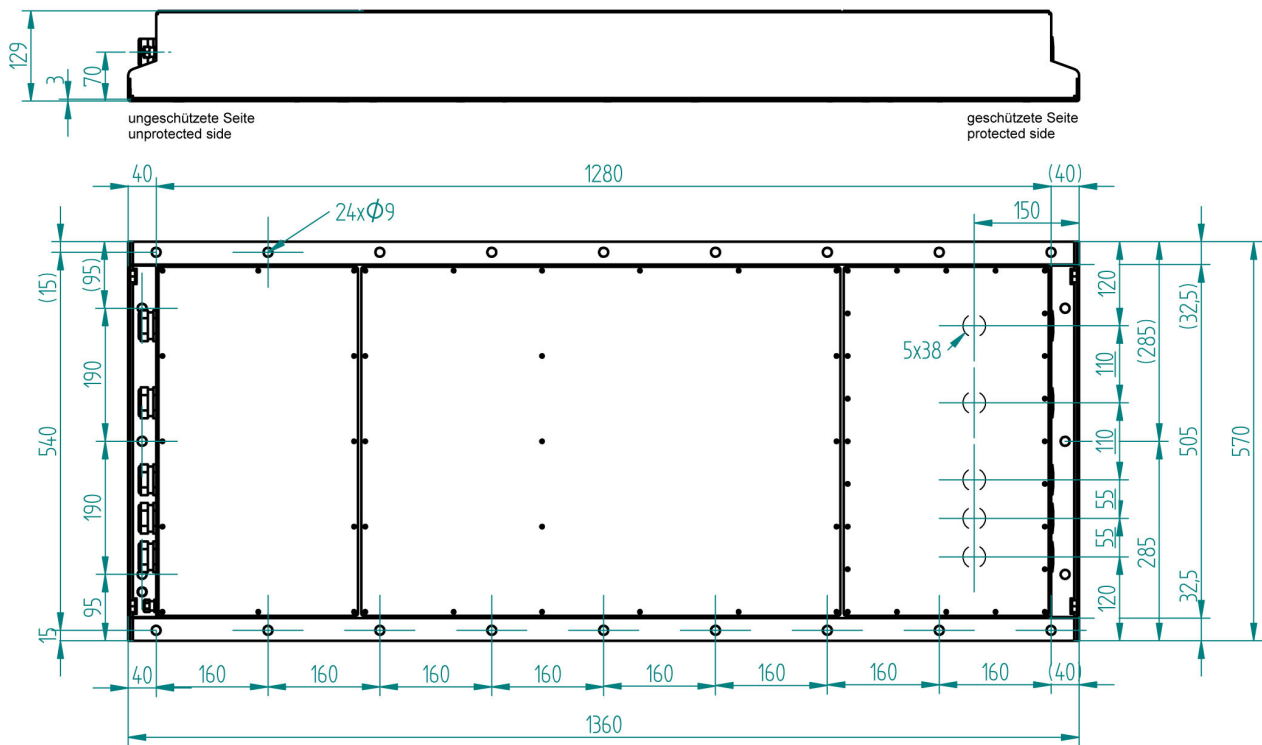

Installation Notes

- The EMP protector / filter has to be installed by electrically skilled personnel.
- The electrical wiring has to be done according to local regulations.
- The max. values stated in this datasheet must not be exceeded under any circumstances.
- PLP-series EMP protector / filter shall be permanently (not pluggable) connected to the grid.
- Residual current circuit breakers shall be used on the protected side of the surge protector, where they are protected from transient overvoltages.
- The EMP protector / filter may be directly installed to a Faraday cage as feed-through device. Otherwise the cabling on the protected side must be shielded.
- Do not use spacers between filter and Faraday cage.
- The screws of the covers shall be slightly lubricated for best performance.

Ordering Information

Part.-Nr: **PLP-FC-400-100**

Type-Nr.: USS-3x400/230V/100A-MIL-STD

Installation Instruction for mechanical shock protection

- The PLP-Series is approved for 3 bar shock protection according to Swiss Federal Office for Civil Protection BABS.
- Installation can be done by screws or direct welding to the Faraday cage. Usually installation using screws or bolts is more convenient.
- If screwed at least 8 pieces equally spaced screws M12 of class 8.8 including washer and spring washer shall be used. The torque shall be 83 Nm. Using more than 8 screws improves the electrical contact with the Faraday cage.
- Installation to a concrete wall requires at least 8 dowels. Each dowel shall have at least the capability to hold 3.8 kN.
- If welded at least 12 equally spaced fillet welds having a length of 50 mm shall be applied.



Warning

High AC earth leakage current! Case of filter (Protective earth) must be solidly and permanently earthed. Always install protective earth first.

Contact

Meteolabor AG
Hofstrasse 92
CH-8620 Wetzikon
Switzerland

Tel: +41 44 934 40 40
E-Mail: info@meteolabor.ch
Internet: www.meteolabor.ch

© by Meteolabor AG
All rights reserved

Content may change without further notice 2023-07
PLP-FC-400-100_e_V2027

EMP Surge Protector / Filter 4 lines (3L+N) 400 / 230 V, 200 A PLP-FC-400-200, PLP-FC Series

Excellent protection of 4 lines (3L+N) 400/230V (50 / 60Hz) for power supply applications.

Fully compliant to MIL-STD-188-125-1

Protection against HEMP / NEMP- and lightning overvoltages as well as against RF-interferences

Multi-stage protection / filter design providing very high transient energy absorption capability

Thermally monitored Surge Protection Devices with status signalization by potential free contact

Rigid stainless steel for direct installation to Faraday cage. Approved for 3 bar blast shock.



Product

Meteolabor PLP-Series EMP Protector / Filter consist of Combinations of coarse and fine protection stages in combination with filtering components. This guarantees optimized protection of mission critical equipment against very fast transient overvoltages (e.g. NEMP / HEMP).

The PLP-FC Series is **fully compliant to MIL-STD-188-125-1**. For details see chapter "3 User Information"

Extremely high surge currents up to 100 kA (8 / 20µs) per line can be diverted.

For safety a capacitor discharge resistor is built in.

Applications

Meteolabor EMP-Protector / Filters protect sensitive electronics such as Computers, telecommunication equipment, controls etc. from damages due to NEMP / HEMP or lightning effects.

Radio frequency interferences are filtered by high quality low-pass filters. The filter is designed for fixed installation with permanent grounding.

Applications range from fixed military facilities (e.g. C⁴I facilities) to civilian or industrial projects requiring high reliability.

Technical Data PLP-FC-400-200

Nominal voltage U_N	3 x 400 / 230 V AC	50 / 60 Hz
Max. operating voltage U_c	3 x 460 / 255 V AC	50 / 60 Hz
Nominal current I_N	200 A	Effective at $T_{amb} 40\text{ °C}$
Max. surge current I_{Max}	100 kA	Each L / N → PE, shape 8 / 20 µs, $T_{amb} 40\text{ °C}$, at least 1 pulse
Max. lightning impulse current I_{imp}	25 kA	Each L / N → PE, shape 10 / 350 µs, $T_{amb} 40\text{ °C}$, at least 1 pulse
DC resistance	< 1.2 mΩ	Each L / N
Residual current MIL-STD-188-125-1	< 10 A	If a full E1 is applied as input signal
Residual voltage surge	< 1.6 kV	L / N → PE, pulse 4 kV / 2 kA according to IEC 61000-4-5
Attenuation	> 80 dB	150 kHz – 2.9 GHz, 50 Ω - System
50 Hz AC-leakage current	< 2 A	L → PE at U_N , 50 Hz
Combination Surge Protection Device	SPD Type 1 + 2 + 3	Fault indication by opening of a potential-free contact
Potential free contact	Normally closed	Max. 250 V AC, 0.5 A, open if at least one SPD has disconnected
Case material	Steel V 2 A	Complete case St 1.4301
Dimensions	1360x570x129 mm	External dimensions, Details see drawing
Weight	ca. 94 kg	
Approval Number BZS	LS SE 19-907	Shock (3 bar) according BABS / BZS

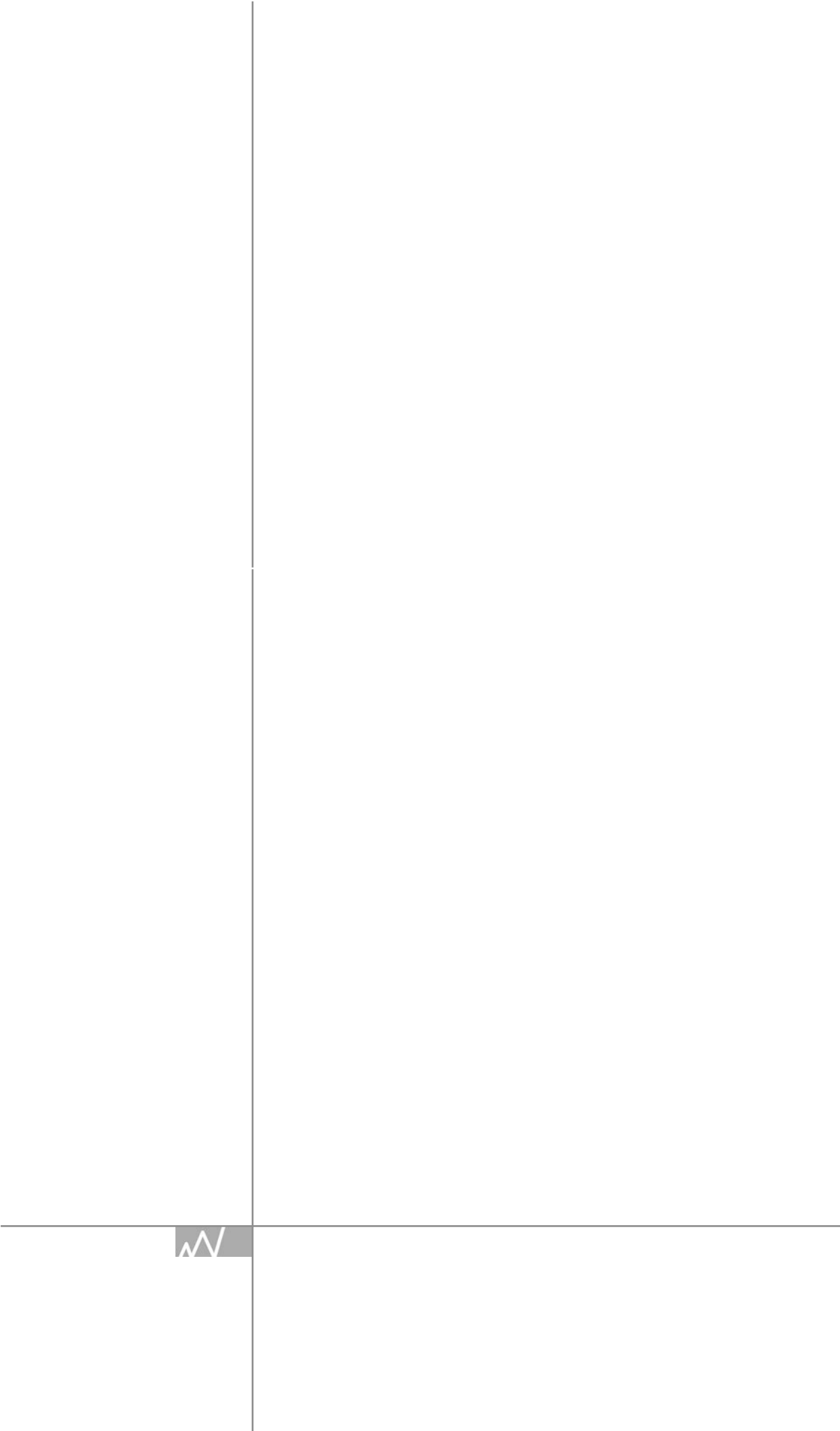



CSP Series

Protection for Coaxial Lines





RF EMP Protector 110 – 500 MHz, 100W, N – N Jack CSP-12101

Protection for 50 Ohm coaxial cables, based on High Pass Filter Technology

For RF - power up to 100 W

Low insertion loss operation from 110 to 500 MHz

N - jack (female) for Input and Output

Feed - through installation inside or outside of wall of Faraday cage or metallic housing

Low residual energy protection against overvoltages produced by NEMP / HEMP, lightning or other transients

10 kA surge current capability on inner conductor



The Meteolabor CSP series RF EMP protectors are specially designed for the protection of coaxial lines.

CSP-12101 handles surge currents up to 10 kA on the inner conductor without degradation of performance. A unique mechanical bulkhead design offers easy feed - through installation and compact fitting into Faraday cages, shielded rooms and mechanical enclosures. Single point of entry concepts can be simply realised.

Various transient protection designs for broadband or limited frequency band operation are available. Generally limited frequency band elements provide lower residual energy in the case of transient overvoltages such as produced by atmospheric discharges (lightning, electrostatic discharge) or a High Altitude Electro-Magnetic Pulse (HEMP), sometimes also referred to as Nuclear Electro-Magnetic Pulse (NEMP) or simply EMP.

Applications

The Meteolabor CSP-12101 RF EMP surge protector element ensures best protection of a broadband VHF and UHF 50 Ohm coaxial line of telecommunication equipment etc. against transient overvoltages (e.g. NEMP / HEMP, lightning).

CSP-12101 is fitted with N - Jacks and is best suited for lines using N connectors, working with RF - power up to 100 W in the frequency range from 110 to 500 MHz. CSP-12101 has very low losses in the passband (110 to 500 MHz), however blocks DC and low frequencies.

Applications range from mission critical equipment, such as fixed or mobile military installations (e.g. C⁴I facilities) to civilian or industrial projects, requiring high reliability and state - of - the - art protection.

Technical Data CSP-12101

Application	50 Ohm coaxial line	For VHF and UHF applications 110 – 500 MHz, max. 100 W
Max. operating power	100 W	Matched load
Max. surge current I_{Max}	10 kA	Inner conductor → ground, shape 8 / 20 μ s
Nominal surge current I_N	7.5 kA	Inner conductor → ground, shape 8 / 20 μ s, 10 pulses at 30s intervals
Residual energy	2 mJ typically	4 kV / 2 kA test pulse, current shape 8 / 20 μ s, 50 Ohm load
Residual voltage	< +/- 65 V	4 kV / 2 kA test pulse, current shape 8 / 20 μ s, 50 Ohm load
Residual energy	400 μ J typically	Fast rising 4 kV, 5 / 50 ns test pulse, 50 Ohm load
Residual voltage	< +/- 750 V	Fast rising 4 kV, 5 / 50 ns test pulse, 50 Ohm load
Frequency range	110 to 500 MHz	Insertion loss \leq 0.2 dB
Return loss	\geq 20 dB	110 to 500 MHz
Connectors	N jack (female)	Unprotected and protected side
Operating temperature	-40°C to +85°C	
Ingress protection	IP 65	when coupled with conform mating connectors
Case material	Alu, nickel-plated	center contacts: gold plating
Installation torque	Max. 20 Nm	Min. 15 Nm for good grounding contact
Dimensions	110 x 27 x \varnothing 73 mm	Major dimensions, details see drawing
Weight	approx. 230 g	

Dimensions [mm]

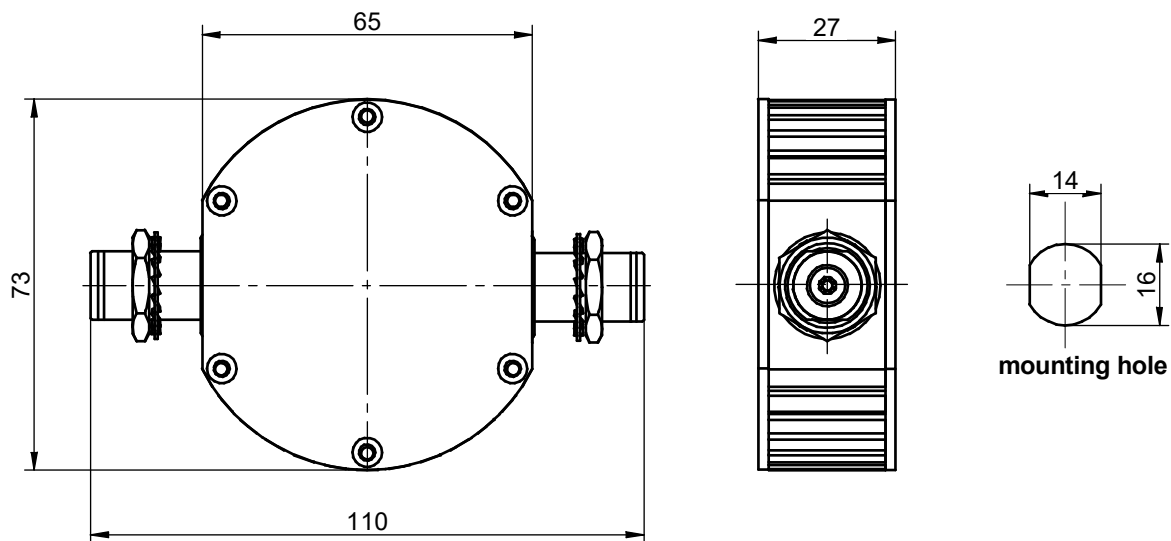

Installation Notes

- The CSP series EMP protectors shall be installed by electrically skilled personnel.
- The electrical wiring must be done according to local regulations.
- The max. values stated in this datasheet must not be exceeded under any circumstances.
- Do not exceed max. installation torque of 20 Nm as this can result in permanent damage.
- CSP series EMP protectors may be directly installed into the wall of a Faraday cage as feed-through device. If not used in a Faraday cage good and very short grounding (min. 16 mm²) is necessary to carry lightning currents of the outer conductor of the coaxial cable.
- CSP-12101 may be installed in front or rear of the bulkhead, however, note that unprotected / protected side must be installed correct, i.e. the protected side must face the protected side of the cable.

General Recommendations for Protection Installation

- In order to achieve the full performance of a protection circuit the application of good-practice EMC design techniques is necessary for the whole system to be protected.
- For EMP - protection usually a shield as an electromagnetic barrier to protect a certain volume is necessary. This shield avoids coupling of radiated disturbances inside the protected volume. In addition to shielding all penetrating wires must be protected from conducted transient interferences by an appropriate POE (point of entry) protection.
- Use tested, high quality POE (point of entry) protection elements for all wires entering an electromagnetic shield and install these as feed-through devices, e.g. the Meteolabor USS-1, USS-2, USP, or PLP series.

Ordering Information / Part Number

CSP-12101 RF EMP surge protector N(f)



Caution

For proper function unprotected / protected side must be installed correctly.

Contact

Meteolabor AG
Hofstrasse 92
CH-8620 Wetzikon
Switzerland

Tel: +41 44 934 40 40
E-Mail: info@meteolabor.ch
Internet: www.meteolabor.ch

by Meteolabor AG
All rights reserved

Content may change without further notice 2023
CSP-12101_e_V2023



RF EMP Protector DC –230 MHz, 10 dBm, N – N Jack CSP-21102

Protection for 50 Ohm coaxial cables, based on GDT / Low Pass Filter Technology

Transmits RF-signal, 1Mbit/s signal and DC - power

Low insertion loss operation from DC to 230 MHz

N - jack (female) for Input and Output

Feed - through installation inside or outside of wall of Faraday cage or metallic housing

Low residual energy protection against overvoltages produced by NEMP / HEMP, lightning or other transients

10 kA surge current capability on inner conductor



The Meteolabor CSP series RF EMP protectors are specially designed for the protection of coaxial lines.

CSP-21102 handles surge currents up to 10 kA on the inner conductor without degradation of performance. A unique mechanical bulkhead design offers easy feed - through installation and compact fitting into Faraday cages, shielded rooms and mechanical enclosures. Single point of entry concepts can be simply realised.

Various transient protection designs for broadband or limited frequency band operation are available. Generally limited frequency band elements provide lower residual energy in the case of transient overvoltages such as produced by atmospheric discharges (lightning, electrostatic discharge) or a High Altitude Electro-Magnetic Pulse (HEMP), sometimes also referred to as Nuclear Electro-Magnetic Pulse (NEMP) or simply EMP.

Applications

The Meteolabor CSP-21102 RF EMP surge protector element ensures best protection against transient overvoltages (e.g. NEMP / HEMP, lightning) for a 50 Ohm coaxial RF-line carrying signals from DC to 230 MHz.

CSP-21102 is fitted with N - Jacks and is best suited for lines using N connectors, working with RF - power up to 10 dBm in the frequency range from DC to 230 MHz. CSP-21102 has very low losses in the passband and also transmits DC up to $\pm 48\text{ V} / 2\text{ A}$ (inner conductor to shield) for remote power supply.

Applications range from mission critical equipment, such as fixed or mobile military installations (e.g. C⁴I facilities) to civilian or industrial projects, requiring high reliability and state-of-the-art protection.

Technical Data CSP-21102

Application	50 Ohm coaxial line	DC (48V / 2A) – 230 MHz, max. 10 dBm RF-power; 1Mbit/s signal
Max. operating parameters	Matched load	$\pm 55\text{ V}/2\text{ A}$ DC power / 10dBm RF-power / 1Mbit/s amplitude max. $\pm 5\text{ V}$
Max. surge current $I_{M\text{ax}}$	10 kA	Inner conductor → ground, shape 8 / 20 μs
Nominal surge current I_N	7.5 kA	Inner conductor → ground, shape 8 / 20 μs , 10 pulses at 30s intervals
Residual energy	8 mJ typically	4 kV / 2 kA test pulse, current shape 8 / 20 μs , 50 Ohm load
Residual voltage	$< \pm 420\text{ V}$	4 kV / 2 kA test pulse, current shape 8 / 20 μs , 50 Ohm load
Residual energy	450 μJ typically	Fast rising 4 kV, 5 / 50 ns test pulse, 50 Ohm load
Residual voltage	$< \pm 600\text{ V}$	Fast rising 4 kV, 5 / 50 ns test pulse, 50 Ohm load
Frequency range	DC to 230 MHz	Insertion loss $\leq 0.2\text{ dB}$
Return loss	$\geq 20\text{ dB}$	DC to 230 MHz
Connectors	N jack (female)	Unprotected and protected side
Operating temperature	-40°C to +85°C	
Ingress protection	IP 65	when coupled with conform mating connectors
Case material	Alu, nickel-plated	center contacts: gold plating
Installation torque	Max. 20 Nm	Min. 15 Nm for good grounding contact
Dimensions	110 x 27 x \varnothing 73 mm	Major dimensions, details see drawing
Weight	approx. 230 g	

Dimensions [mm]

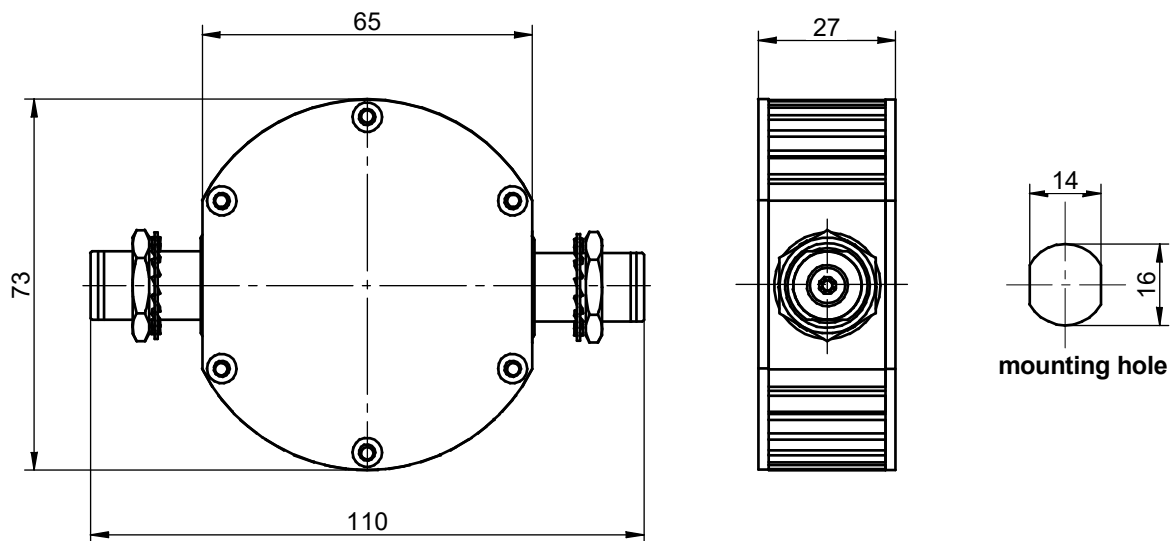

Installation Notes

- The CSP series EMP protectors shall be installed by electrically skilled personnel.
- The electrical wiring must be done according to local regulations.
- The max. values stated in this datasheet must not be exceeded under any circumstances.
- Do not exceed max. installation torque of 20 Nm as this can result in permanent damage.
- CSP series EMP protectors may be directly installed into the wall of a Faraday cage as feed - through device. If not used in a Faraday cage good and very short grounding (min. 16 mm²) is necessary to carry lightning currents of the outer conductor of the coaxial cable.
- CSP-21102 may be installed in front or rear of the bulkhead, however, note that unprotected / protected side must be installed correct, i.e. the protected side must face the protected side of the cable.

General Recommendations for Protection Installation

- In order to achieve the full performance of a protection circuit the application of good-practice EMC design techniques is necessary for the whole system to be protected.
- For EMP - protection usually a shield as an electromagnetic barrier to protect a certain volume is necessary. This shield avoids coupling of radiated disturbances inside the protected volume. In addition to shielding all penetrating wires must be protected from conducted transient interferences by an appropriate POE (point of entry) protection.
- Use tested, high quality POE (point of entry) protection elements for all wires entering an electromagnetic shield and install these as feed - through devices, e.g. the Meteolabor USS-1, USS-2, USP, or PLP series.

Ordering Information / Part Number

CSP-21102 RF EMP surge protector N(f)



Caution

For proper function unprotected / protected side must be installed correctly.

Contact

Meteolabor AG
Hofstrasse 92
CH-8620 Wetzikon
Switzerland

Tel: +41 44 934 40 40
E-Mail: info@meteolabor.ch
Internet: www.meteolabor.ch

© by Meteolabor AG
All rights reserved

Content may change without further notice 2023-07
CSP-21102_e_V2023

RF EMP Protector DC – 1 GHz, 150W, N – N Jack CSP-40101

Protection for 50 Ohm coaxial cables based on Gas Discharge Tube (GDT) technology

Equipped with GDT for RF-power up to 150 W

Broad band, low loss operation from DC to 1 GHz

N-jack (female) for Input and Output

Feed-through installation into wall of Faraday cage or metallic housing

Protects against overvoltages produced by NEMP / HEMP, lightning or other transients

High surge current capability



Product

The Meteolabor CSP series RF EMP protectors are specially designed for the protection of coaxial lines. Surge currents up to 20 kA or single strikes up to 30 kA can be handled.

A unique mechanical bulkhead design offers easy feed-through installation and compact fitting into Faraday cages, shielded rooms and mechanical enclosures. Single point of entry concepts can be simply realised. This allows clear separation of unprotected and protected side.

Various transient protection designs for broadband or limited frequency band operation are available. Generally limited frequency band elements provide lower residual energy in the case of transient overvoltages such as produced by atmospheric discharges (lightning, electrostatic discharge) or a High Altitude Electro-Magnetic Pulse (HEMP), sometimes referred to as NEMP

Applications

The Meteolabor CSP-40101 RF EMP surge protector element ensures best protection of a broadband 50 Ohm coaxial line of telecommunication equipment etc. against transient overvoltages (e.g. NEMP / HEMP, lightning).

CSP-40101 is best suited for lines using N connectors and working with continuous power up to 150 W and various frequencies from 0 to 1 GHz.

Applications range from mission critical equipment, such as fixed or mobile military installations (e.g. C⁴ facilities) to civilian or industrial projects, requiring high reliability and state-of-the-art protection.

CSP-40101 has been successfully used in many projects, where HEMP - testing according to RS - 105 on threat-level has been conducted

Technical Data CSP-40101

Application	50 Ohm coaxial line	For broadband applications DC – 1 GHz, max. 150 W
Standards	IEC-61000-4-5	Compliant with category 0-4
Max. operating power	150 W	With matched load, mismatch or higher power may trigger GDT
Max. surge current I_{Max}	25 kA	Inner conductor → ground, shape 8 / 20 μ s, single pulse
Nominal surge current I_N	20 kA	Inner conductor → ground, shape 8 / 20 μ s, 10 pulses at 30s intervals
Residual energy	350 μ J typically	4 kV / 2 kA test pulse, current shape 8 / 20 μ s, 50 Ohm load
Frequency range	0 to 1000 MHz	Insertion loss \leq 0.1 dB
Return loss	\geq 26 dB	0 to 1000 MHz
DC-spark-over voltage U_{Zstat}	230 V \pm 20%	Dynamic spark-over voltage U_{Zdyn} \leq 650 V at 1kV/ μ s typically
Connectors	N jack (female)	Unprotected and protected side
Operating temperature	-40°C to +85°C	
Ingress protection	IP 65	when coupled with conform mating connectors
Case material	Brass	Housing: nickel-free plating, center contacts: gold plating
Installation torque	Max. 20 Nm	Min. 15 Nm for good grounding contact
Dimensions	55.2 x ϕ 25.9 mm	Major dimensions, details see drawing
Weight	approx. 120 g	

Dimensions [mm]

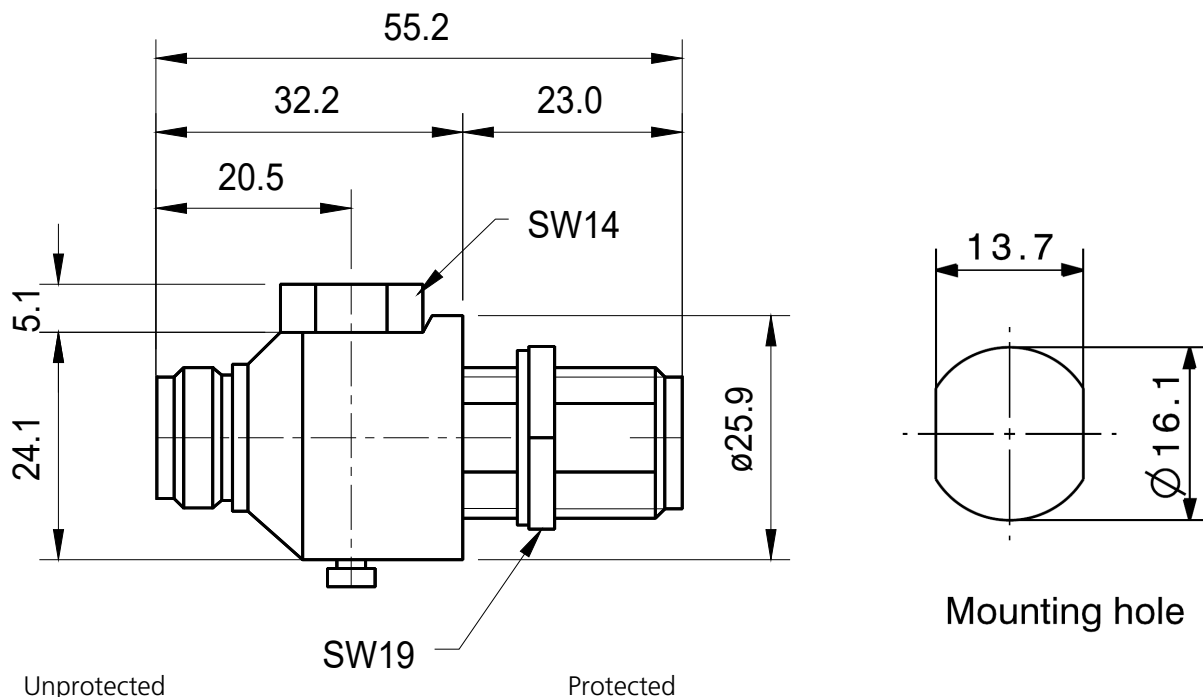

Installation Notes

- The CSP series EMP protectors shall be installed by electrically skilled personnel.
- The electrical wiring must be done according to local regulations.
- The max. values stated in this datasheet must not be exceeded under any circumstances.
- Do not exceed max. installation torque of 20 Nm as this can result in permanent damage.
- CSP series EMP protectors may be directly installed into the wall of a Faraday cage as feed-through device. If not used in a Faraday cage good and very short grounding (min. 16 mm²) is necessary to carry lightning currents of the outer conductor of the coaxial cable.

General Recommendations for Protection Installation

- In order to achieve the full performance of a protection circuit the application of good-practice EMC design techniques is necessary for the whole system to be protected.
- For EMP-protection usually a shield as an electromagnetic barrier to protect a certain volume is necessary. This shield avoids coupling of radiated disturbances inside the protected volume. In addition to shielding all penetrating wires must be protected from conducted transient interferences by an appropriate POE (point of entry) protection.
- Use tested, high quality POE (point of entry) protection elements for all wires entering an electromagnetic shield and install these as feed-through devices, e.g. the Meteolabor USS-1, USS-2, USP, or PLP series.

Ordering Information / Part Number

CSP-40101 RF EMP surge protector N(f)

**Caution**

Always keep Gas Discharge Tube (GDT) inserted.
Removal of GDT will result in loss of protection.

Contact

Meteolabor AG
Hofstrasse 92
CH-8620 Wetzikon
Switzerland

Tel: +41 44 934 40 40
E-Mail: info@meteolabor.ch
Internet: www.meteolabor.ch

© by Meteolabor AG
All rights reserved

Content may change without further notice 2023-07
CSP-40101_e_V2023

RF EMP Protector DC – 1 GHz, 150 W, BNC – BNC jack CSP-40102

- Protection for 50 Ohm coaxial cables based on Gas Discharge Tube (GDT) technology**
- Equipped with GDT for RF-power up to 150 W**
- Broad band, low loss operation from DC to 1 GHz**
- BNC jack (female) for Input and Output**
- Feed-through installation into wall of Faraday cage or metallic housing**
- Protects against overvoltages produced by NEMP / HEMP, lightning or other transients**
- High surge current capability**



Product

The Meteolabor CSP series RF EMP protectors are specially designed for the protection of coaxial lines. Surge currents up to 20 kA or single strikes up to 30 kA can be handled.

A unique mechanical bulkhead design offers easy feed-through installation and compact fitting into Faraday cages, shielded rooms and mechanical enclosures. Single point of entry concepts can be simply realised. This allows clear separation of unprotected and protected side.

Various transient protection designs for broadband or limited frequency band operation are available. Generally limited frequency band elements provide lower residual energy in the case of transient overvoltages such as produced by atmospheric discharges (lightning, electrostatic discharge) or a High Altitude Electro-Magnetic Pulse (HEMP), sometimes also referred to as Nuclear Electro-Magnetic Pulse (NEMP) or simply EMP.

Applications

The Meteolabor CSP-40102 RF EMP surge protector element ensures best protection of a broadband 50 Ohm coaxial line of telecommunication equipment etc. against transient overvoltages (e.g. NEMP / HEMP, lightning).

CSP-40102 is best suited for lines using BNC connectors and working with continuous power up to 150 W and various frequencies from 0 to 1 GHz.

Applications range from mission critical equipment, such as fixed or mobile military installations (e.g. C⁴ facilities) to civilian or industrial projects, requiring high reliability and state-of-the-art protection.

CSP-40102 has been successfully used in many projects, where HEMP - testing according to RS - 105 on threat-level has been conducted

Technical Data CSP-40102

Application	50 Ohm coaxial line	For broadband applications DC – 1 GHz, max. 150 W
Nominal operating power	150 W	With matched load, mismatch or higher power may trigger GDT
Max. surge current I_{Max}	25 kA	Inner conductor → ground, shape 8 / 20 μs, single pulse
Nominal surge current I_N	20 kA	Inner conductor → ground, shape 8 / 20 μs, 10 pulses at 30s intervals
Residual energy	350 μJ typically	4 kV / 2 kA test pulse, current shape 8 / 20 μs, 50 Ohm load
Frequency range	0 to 1000 MHz	Insertion loss ≤ 0.1 dB
Return loss	≥ 19 dB	0 to 1000 MHz; ≥ 26 dB 0 to 300 MHz
DC-spark-over voltage U_{Zstat}	230 V ±20%	Dynamic spark-over voltage U_{Zdyn} ≤ 650 V at 1kV / μs typically
Connectors	BNC (female)	Unprotected and protected side
Operating temperature	-40°C to +85°C	
Ingress protection	IP 20	when coupled with conform mating connectors
Case material	Brass	Housing: nickel-free plating, center contacts: gold plating
Installation torque	Max. 20 Nm	Min. 15 Nm for good grounding contact
Dimensions	57.2 x ø 25.9 mm	Major dimensions, details see drawing
Weight	approx. 75 g	

Dimensions [mm]

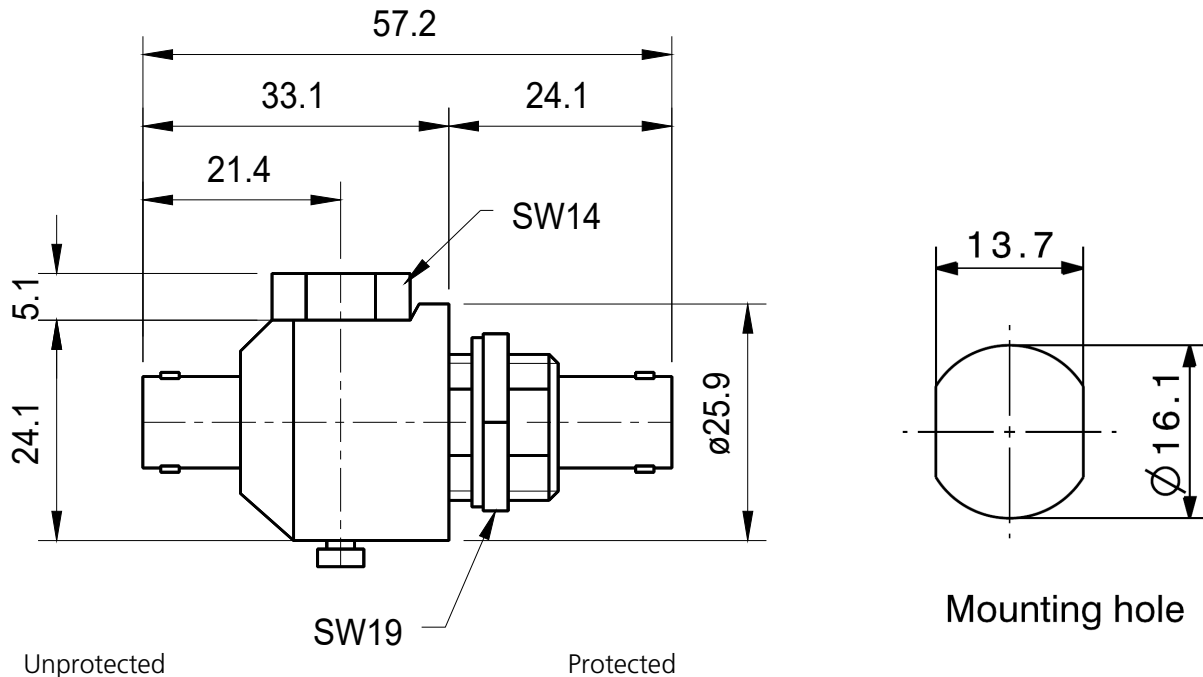

Installation Notes

- The CSP series EMP protectors shall be installed by electrically skilled personnel.
- The electrical wiring must be done according to local regulations.
- The max. values stated in this datasheet must not be exceeded under any circumstances.
- Do not exceed max. installation torque of 20 Nm as this can result in permanent damage.
- CSP series EMP protectors may be directly installed into the wall of a Faraday cage as feed-through device. If not used in a Faraday cage good and very short grounding (min. 16 mm²) is necessary to carry lightning currents of the outer conductor of the coaxial cable.

General Recommendations for Protection Installation

- In order to achieve the full performance of a protection circuit the application of good-practice EMC design techniques is necessary for the whole system to be protected.
- For EMP-protection usually a shield as an electromagnetic barrier to protect a certain volume is necessary. This shield avoids coupling of radiated disturbances inside the protected volume. In addition to shielding all penetrating wires must be protected from conducted transient interferences by an appropriate POE (point of entry) protection.
- Use tested, high quality POE (point of entry) protection elements for all wires entering an electromagnetic shield and install these as feed-through devices, e.g. the Meteolabor USS-1, USS-2, USP, or PLP series.

Ordering Information / Part Number

CSP-40102 RF EMP surge protector BNC (f)



Caution

Always keep Gas Discharge Tube (GDT) inserted.
Removal of GDT will result in loss of protection.

Contact

Meteolabor AG
Hofstrasse 92
CH-8620 Wetzikon
Switzerland

Tel: +41 44 934 40 40
E-Mail: info@meteolabor.ch
Internet: www.meteolabor.ch

© by Meteolabor AG
All rights reserved

Content may change without further notice 2023
CSP-40101_e_V2023



RF EMP Protector DC – 2.5 GHz, 150W, N – N Jack CSP-40103

- Protection for 50 Ohm coaxial cables based on Gas Discharge Tube (GDT) technology**
- Equipped with GDT for RF-power up to 150 W**
- Broad band, low loss operation from DC to 2.5 GHz**
- N-jack (female) for Input and Output**
- Feed-through installation into wall of Faraday cage or metallic housing**
- Protects against overvoltages produced by NEMP / HEMP, lightning or other transients**
- High surge current capability**



Product

The Meteolabor CSP series RF EMP protectors are specially designed for the protection of coaxial lines. Surge currents up to 20 kA or single strikes up to 30 kA can be handled.

A unique mechanical bulkhead design offers easy feed-through installation and compact fitting into Faraday cages, shielded rooms and mechanical enclosures. Single point of entry concepts can be simply realised. This allows clear separation of unprotected and protected side.

Various transient protection designs for broadband or limited frequency band operation are available. Generally limited frequency band elements provide lower residual energy in the case of transient overvoltages such as produced by atmospheric discharges (lightning, electrostatic discharge) or a High Altitude Electro-Magnetic Pulse (HEMP), sometimes also referred to as NEMP.

Applications

The Meteolabor CSP-40103 RF EMP surge protector element ensures best protection of a broadband 50 Ohm coaxial line of telecommunication equipment etc. against transient overvoltages (e.g. NEMP / HEMP, lightning).

CSP-40103 is best suited for lines using N connectors and working with continuous power up to 150 W and various frequencies from 0 to 2.5 GHz.

Applications range from mission critical equipment, such as fixed or mobile military installations (e.g. C⁴I facilities) to civilian or industrial projects, requiring high reliability and state-of-the-art protection.

CSP-40103 has been successfully used in many projects, where HEMP-testing according to RS-105 on threat-level has been conducted.

Technical Data CSP-40103

Application	50 Ohm coaxial line	For broadband applications DC – 2.5 GHz, max. 150 W
Standards	IEC-61000-4-5	Compliant to categories 0-4
Max. operating power	150 W	With matched load, mismatch or higher power may trigger GDT
Max. surge current I_{Max}	25 kA	Inner conductor → ground, shape 8 / 20 μ s, single pulse
Nominal surge current I_N	20 kA	Inner conductor → ground, shape 8 / 20 μ s, 10 pulses at 30s intervals
Residual energy	350 μ J typically	4 kV / 2 kA test pulse, current shape 8 / 20 μ s, 50 Ohm load
Frequency range	0 to 2500 MHz	Insertion loss \leq 0.2 dB
Return loss	\geq 20 dB	0 to 2500 MHz
DC-spark-over voltage U_{Zstat}	230 V \pm 20%	Dynamic spark-over voltage $U_{Zdyn} \leq$ 650 V at 1kV / μ s typically
Connectors	N jack (female)	Unprotected and protected side
Operating temperature	-40°C to +85°C	
Ingress protection	IP 66	when coupled with conform mating connectors
Case material	Brass	Housing: nickel-free plating, center contacts: gold plating
Installation torque	Max. 20 Nm	Min. 15 Nm for good grounding contact
Dimensions	69 x \varnothing 25.9 mm	Major dimensions, details see drawing
Weight	approx. 130 g	

Dimensions [mm]

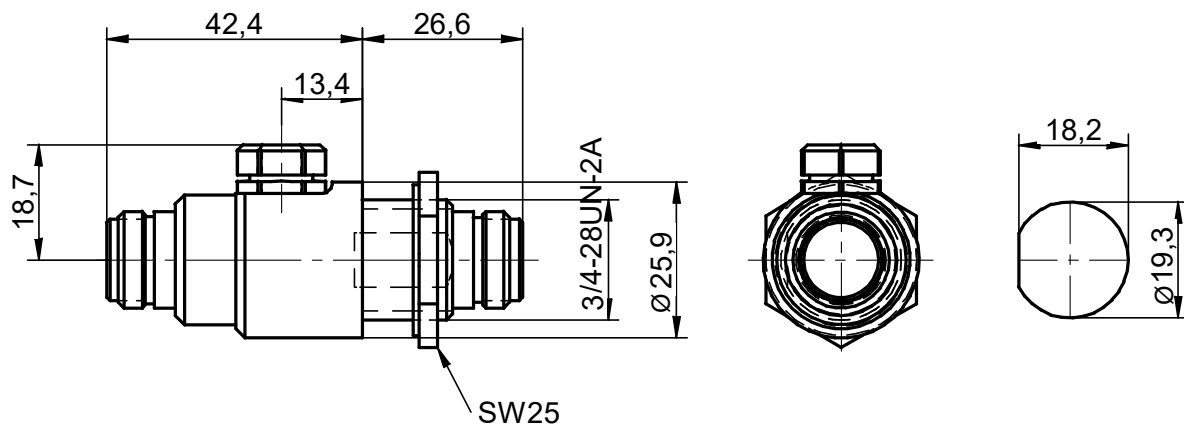

Unprotected

Protected

Installation Notes

- The CSP series EMP protectors shall be installed by electrically skilled personnel.
- The electrical wiring must be done according to local regulations.
- The max. values stated in this datasheet must not be exceeded under any circumstances.
- Do not exceed max. installation torque of 20 Nm as this can result in permanent damage.
- CSP series EMP protectors may be directly installed into the wall of a Faraday cage as feed-through device. If not used in a Faraday cage good and very short grounding (min. 16 mm²) is necessary to carry lightning currents of the outer conductor of the coaxial cable.

General Recommendations for Protection Installation

- In order to achieve the full performance of a protection circuit the application of good-practice EMC design techniques is necessary for the whole system to be protected.
- For EMP-protection usually a shield as an electromagnetic barrier to protect a certain volume is necessary. This shield avoids coupling of radiated disturbances inside the protected volume. In addition to shielding all penetrating wires must be protected from conducted transient interferences by an appropriate POE (point of entry) protection.
- Use tested, high quality POE (point of entry) protection elements for all wires entering an electromagnetic shield and install these as feed-through devices, e.g. the Meteolabor USS-1, USS-2, USP, or PLP series.

Ordering Information / Part Number

CSP-40103 RF EMP surge protector N(f)



Caution

Always keep Gas Discharge Tube (GDT) inserted. Removal of GDT will result in loss of protection.

Contact

Meteolabor AG
Hofstrasse 92
CH-8620 Wetzikon
Switzerland

Tel: +41 44 934 40 40
E-Mail: info@meteolabor.ch
Internet: www.meteolabor.ch

© by Meteolabor AG
All rights reserved

Content may change without further notice 2023-07
CSP-40103_e_V2023



RF EMP Protector DC – 5800 MHz, 60 W, N – N Jack CSP-41101

Protection for 50 Ohm coaxial cables based on Gas Discharge Tube (GDT) technology

Equipped with GDT for RF - power up to 60 W

Broad band, low loss operation from DC to 5.8 GHz

N - jack (female) for Input and Output

Feed - through installation into wall of Faraday cage or metallic housing

Protects against overvoltages produced by NEMP / HEMP, lightning or other transients

Up to 10 kA surge current capability



The Meteolabor CSP series RF EMP protectors are specially designed for the protection of coaxial lines. Surge currents up to 5 kA or single strikes up to 10 kA can be handled, some models handle even higher surges.

A unique mechanical bulkhead design offers easy feed-through installation and compact fitting into Faraday cages, shielded rooms and mechanical enclosures. Single point of entry concepts can be simply realised. This allows clear separation of unprotected and protected side.

Various transient protection designs for broadband or limited frequency band operation are available. Generally limited frequency band elements provide lower residual energy in the case of transient overvoltages such as produced by atmospheric discharges (lightning, electrostatic discharge) or a High Altitude Electro-Magnetic Pulse (HEMP), sometimes also referred to as Nuclear Electro-Magnetic Pulse (NEMP) or simply EMP.

Applications

The Meteolabor CSP-41101 RF EMP surge protector element ensures best protection of a broadband 50 Ohm coaxial line of telecommunication equipment etc. against transient overvoltages (e.g. NEMP / HEMP, lightning).

CSP-41101 is best suited for lines using N connectors and working with continuous power up to 60 W and various frequencies from 0 to 5.8 GHz.

Applications range from mission critical equipment, such as fixed or mobile military installations (e.g. C4I facilities) to civilian or industrial projects, requiring high reliability and state-of-the-art protection.

CSP-41101 has been successfully used in many projects, where HEMP-testing according to RS - 105 on threat-level has been conducted

Technical Data CSP-41101

Application	50 Ohm coaxial line	For broadband applications DC – 5.8 GHz, max. 60 W
Max. operating power	60 W	With matched load, mismatch or higher power may trigger GDT
Max. operating voltage / current	40 V / 3 A	DC - power must be short-circuit current limited to < 0.5 A
Max. surge current I_{Max}	10 kA	Inner conductor → ground, shape 8 / 20 μ s, single pulse
Nominal surge current I_N	5 kA	Inner conductor → ground, shape 8 / 20 μ s, 5 pulses at 30s intervals
Residual energy	250 μ J typically	4 kV / 2 kA test pulse, current shape 8 / 20 μ s, 50 Ohm load
Frequency range	0 to 5800 MHz	Insertion loss \leq 0.2 dB
Return loss	\geq 20 dB	0 to 5800 MHz
DC-spark-over voltage U_{Zstat}	200 V	Dynamic spark - over voltage $U_{Zdyn} = 800$ V at 1 kV/ μ s typically
Connectors	N jack (female)	Unprotected and protected side
Operating temperature	-40°C to +85°C	
Ingress protection	IP 67	when coupled with conform mating connectors
Case material	Brass	with gold plating
Installation torque	Max. 20 Nm	Min. 15 Nm for good grounding contact
Dimensions	48.1 x \varnothing 25.9 mm	Major dimensions, details see drawing
Weight	approx. 90 g	

Dimensions [mm]

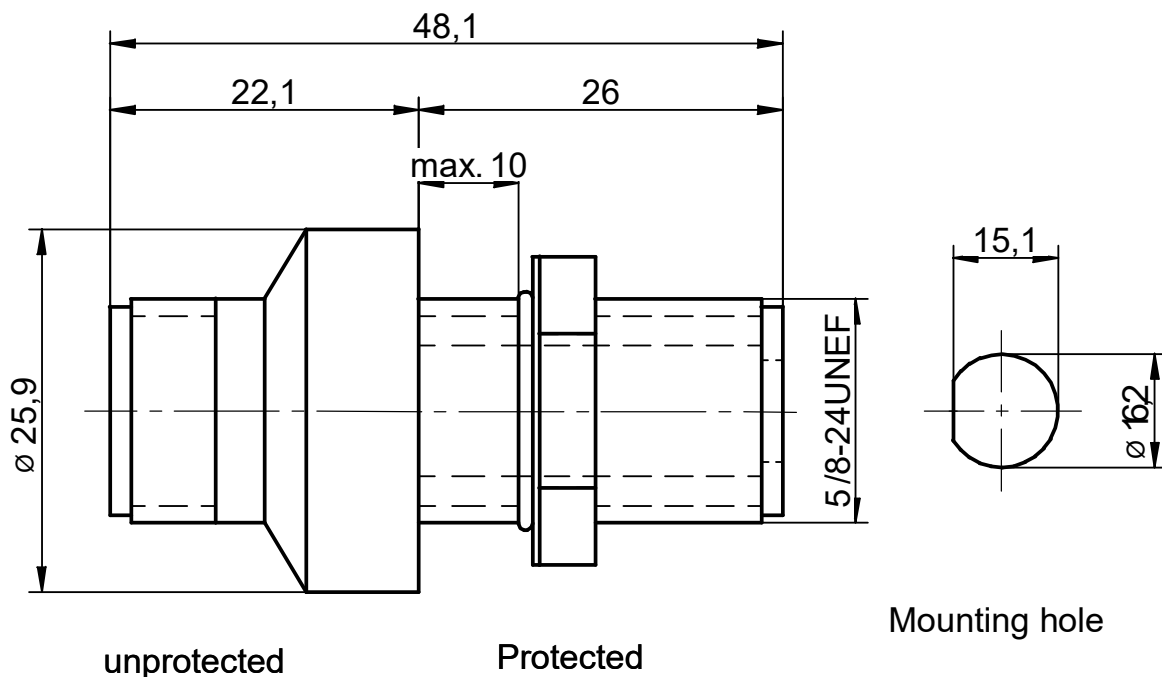

Installation Notes

- The CSP series EMP protectors shall be installed by electrically skilled personnel.
- The electrical wiring must be done according to local regulations.
- The max. values stated in this datasheet must not be exceeded under any circumstances.
- Do not exceed max. installation torque of 20 Nm as this can result in permanent damage.
- CSP series EMP protectors may be directly installed into the electrically conducting wall of a Faraday cage as feed - through device. If not used in a Faraday cage good and very short grounding (min. 16 mm²) is necessary to carry lightning currents of the outer conductor of the coaxial cable.

General Recommendations for Protection Installation

- In order to achieve the full performance of a protection circuit the application of good - practice EMC design techniques is necessary for the whole system to be protected.
- For EMP - protection usually a shield as an electromagnetic barrier to protect a certain volume is necessary. This shield avoids coupling of radiated disturbances inside the protected volume. In addition to shielding all penetrating wires must be protected from conducted transient interferences by an appropriate POE (point of entry) protection.
- Use tested, high quality POE (point of entry) protection elements for all wires entering an electromagnetic shield and install these as feed-through devices, e.g. the Meteolabor USS-1, USS-2, USP, or PLP series.

Ordering Information / Part Number

CSP-41101 RF EMP surge protector N (f)



Caution

The Gas Discharge Tube (GDT) is permanently inserted. Do not attempt to open.
For reliable extinction of GDT it is very important to limit DC short-circuit current to 0.5 A or less

Contact

Meteolabor AG
Hofstrasse 92
CH-8620 Wetzikon
Switzerland

Tel: +41 44 934 40 40
E-Mail: info@meteolabor.ch
Internet: www.meteolabor.ch

© by Meteolabor AG
All rights reserved

Content may change without further notice 202-073
CSP-41101_e_V2023

RF EMP Protector DC – 5800 MHz, 60 W, SMA Jacks CSP-41102

Protection for 50 Ohm coaxial cables based on coaxial Gas Discharge Tube (GDT) technology
Equipped with GDT for RF - power up to 60 W
Broad band, low loss operation from DC to 5.8 GHz
SMA - jack (female) for Input and Output
Feed - through installation into wall of Faraday cage or metallic housing
Protects against overvoltages produced by NEMP / HEMP, lightning or other transients
Up to 10 kA surge current capability



The Meteolabor CSP series RF EMP protectors are specially designed for the protection of coaxial lines. Surge currents up to 5 kA or single strikes up to 10 kA can be handled, some models handle even higher surges.

A unique mechanical bulkhead design offers easy feed-through installation and compact fitting into Faraday cages, shielded rooms and mechanical enclosures. Single point of entry concepts can be simply realised. This allows clear separation of unprotected and protected side.

Various transient protection designs for broadband or limited frequency band operation are available. Generally limited frequency band elements provide lower residual energy in the case of transient overvoltages such as produced by atmospheric discharges (lightning, electrostatic discharge) or a High Altitude Electro-Magnetic Pulse (HEMP), sometimes also referred to as Nuclear Electro - Magnetic Pulse (NEMP) or simply EMP.

Applications

The Meteolabor CSP-41102 RF EMP surge protector element ensures best protection of a broadband 5.8 GHz 50 Ohm coaxial line of telecommunication equipment etc. against transient overvoltages (e.g. NEMP / HEMP, lightning).

CSP-41102 is best suited for lines using SMA connectors and working with continuous power up to 60 W and various frequencies from 0 to 5.8 GHz.

Applications range from mission critical equipment, such as fixed or mobile military installations (e.g. C⁴I facilities) to civilian or industrial projects, requiring high reliability and state-of-the-art protection.

CSP-41102 has been successfully used in many projects, where HEMP-testing according to RS-105 on threat-level has been conducted

Technical Data CSP-41102

Application	50 Ohm coaxial line	For broadband applications DC – 5.8 GHz, max. 60 W
Max. operating power	60 W	With matched load, mismatch or higher power may trigger GDT
Max. operating voltage / current	40 V / 3 A	DC-power must be short-circuit current limited to < 0.5 A
Max. surge current I_{Max}	10 kA	Inner conductor → ground, shape 8 / 20 μ s, single pulse
Nominal surge current I_N	5 kA	Inner conductor → ground, shape 8 / 20 μ s, 10 pulses at 30s intervals
Residual energy	250 μ J typically	4 kV / 2 kA test pulse, current shape 8 / 20 μ s, 50 Ohm load
Frequency range	0 to 5800 MHz	Insertion loss \leq 0.2 dB
Return loss	\geq 20 dB	0 to 5800 MHz
DC-spark-over voltage U_{Zstat}	200 V \pm 25 %	Dynamic spark-over voltage U_{Zdyn} = 800 V at 1 kV / μ s typically
Connectors	SMA jack (female)	Unprotected and protected side
Operating temperature	-40°C to +85°C	
Ingress protection	IP 20	when coupled with conform mating connectors
Case material	Brass	with gold plating
Installation torque	Max. 20 Nm	Min. 15 Nm for good grounding contact
Dimensions	36.6 x \varnothing 17 mm	Major dimensions, details see drawing
Weight	approx. 50 g	

Dimensions [mm]

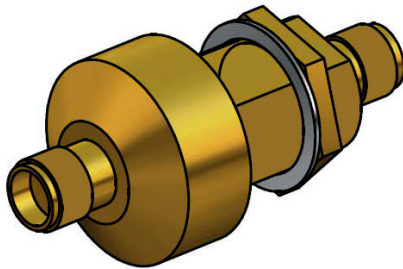
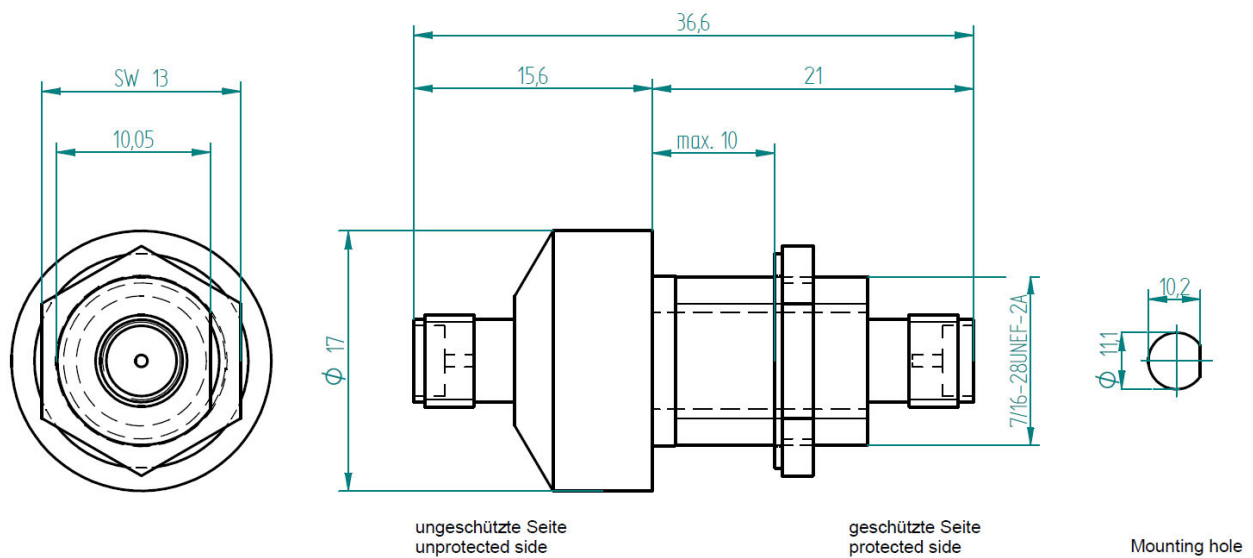

Installation Notes

- The CSP series EMP protectors shall be installed by electrically skilled personnel.
- The electrical wiring must be done according to local regulations.
- The max. values stated in this datasheet must not be exceeded under any circumstances.
- Do not exceed max. installation torque of 20 Nm as this can result in permanent damage.
- CSP series EMP protectors may be directly installed into the electrically conducting wall of a Faraday cage as feed-through device. If not used in a Faraday cage good and very short grounding (min. 16 mm²) is necessary to carry lightning currents of the outer conductor of the coaxial cable.

Ordering Information / Part Number

CSP-41102 RF EMP surge protector SMA (f)

General Recommendations for Protection Installation

- In order to achieve the full performance of a protection circuit the application of good-practice EMC design techniques is necessary for the whole system to be protected.
- For EMP-protection usually a shield as an electromagnetic barrier to protect a certain volume is necessary. This shield avoids coupling of radiated disturbances inside the protected volume. In addition to shielding all penetrating wires must be protected from conducted transient interferences by an appropriate POE (point of entry) protection.
- Use tested, high quality POE (point of entry) protection elements for all wires entering an electromagnetic shield and install these as feed-through devices, e.g. the Meteolabor USS-1, USS-2, USP, or PLP series.



Caution

The Gas Discharge Tube (GDT) is permanently inserted. Do not attempt to open.
For reliable extinction of GDT it is very important to limit DC short-circuit current to 0.5 A or less

Contact

Meteolabor AG
Hofstrasse 92
CH-8620 Wetzikon
Switzerland

Tel: +41 44 934 40 40
E-Mail: info@meteolabor.ch
Internet: www.meteolabor.ch

© by Meteolabor AG
All rights reserved

Content may change without further notice 2023-07
CSP-41102_e_V2023



RF EMP Protector DC – 2000 MHz, 100 W, N75 – N75 CSP-42201

Protection for 75 Ohm coaxial cables based on Gas Discharge Tube (GDT) technology

Equipped with GDT for RF-power up to 100 W

Broad band, low loss operation from DC to 2 GHz

N75 - jack (female) for Input and Output

Feed - through installation into wall of Faraday cage or metallic housing

Protects against overvoltages produced by NEMP / HEMP, lightning or other transients

High surge current capability



The Meteolabor CSP series RF EMP protectors are specially designed for the protection of coaxial lines. Depending on model, nominal surge currents up to 20 kA or single strikes up to 25 kA can be handled.

A unique mechanical bulkhead design offers easy feed-through installation and compact fitting into Faraday cages, shielded rooms and mechanical enclosures. Single point of entry concepts can be simply realised. This allows clear separation of unprotected and protected side.

Various transient protection designs for broadband or limited frequency band operation are available. Generally limited frequency band elements provide lower residual energy in the case of transient overvoltages such as produced by atmospheric discharges (lightning, electrostatic discharge) or a High Altitude Electro-Magnetic Pulse (HEMP), sometimes also referred to as NEMP.

Applications

The Meteolabor CSP-42201 RF EMP surge protector element ensures best protection of a broadband 75 Ohm coaxial line of telecommunication equipment etc. against transient overvoltages (e.g. NEMP / HEMP, lightning).

CSP-42201 is best suited for lines using N75 connectors and working with continuous power up to 100 W and various frequencies from 0 to 2 GHz.

Applications range from mission critical equipment, such as fixed or mobile military installations (e.g. C⁴I facilities) to civilian or industrial projects, requiring high reliability and state-of-the-art protection.

CSP-42201 has been successfully used in many projects, where HEMP - testing according to RS - 105 on threat-level has been conducted.

Technical Data CSP-42201

Application	75 Ohm coaxial line	For broadband applications DC – 2 GHz, max. 100 W
Standards	IEC-61000-4-5	Compliant to categories 0-4
Max. operating power	100 W	With matched load; mismatch or higher power may trigger GDT
Max. surge current I_{Max}	25 kA	Inner conductor → ground, shape 8 / 20 μ s, single pulse
Nominal surge current I_N	20 kA	Inner conductor → ground, shape 8 / 20 μ s, 10 pulses at 30s intervals
Residual energy	350 μ J typically	4 kV / 2 kA test pulse, current shape 8 / 20 μ s, 75 Ohms load
Frequency range	0 to 2000 MHz	Insertion loss \leq 0.2 dB
Return loss	\geq 15 dB	0 to 2000 MHz; \geq 16.5 dB from 0 to 1500 MHz
DC-spark-over voltage U_{Zstat}	230 V \pm 20 %	Dynamic spark-over voltage $U_{Zdyn} \leq$ 650 V at 1 kV/ μ s typically
Connectors	N 75 jack (female)	Unprotected and protected side; Caution: do not mate with 50 Ohms!
Operating temperature	-40°C to +85°C	
Ingress protection	IP 65	when coupled with conform mating connectors
Case material	Brass	Nickel plating; center contacts: gold plating
Installation torque	Max. 20 Nm	Min. 15 Nm recommended for good grounding contact
Dimensions	69 x \varnothing 25.9 mm	Major dimensions, details see drawing
Weight	approx. 140 g	

Dimensions [mm]

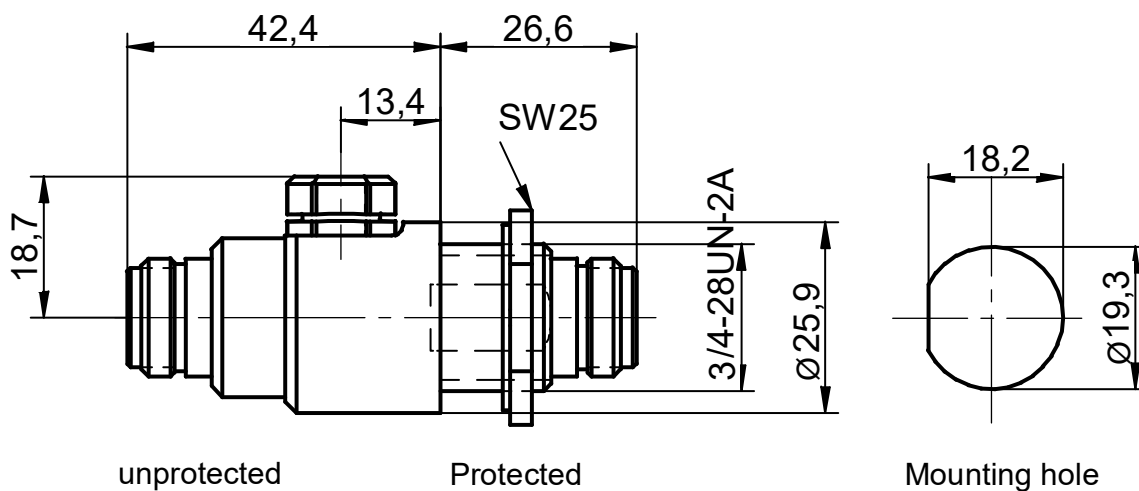

Installation Notes

- The CSP series EMP protectors shall be installed by electrically skilled personnel.
- The electrical wiring must be done according to local regulations.
- The max. values stated in this datasheet must not be exceeded under any circumstances.
- Do not exceed max. installation torque of 20 Nm as this can result in permanent damage.
- CSP series EMP protectors may be directly installed into the electrically conducting wall of a Faraday cage as feed-through device. If not used in a Faraday cage good and very short grounding (min. 16 mm²) is necessary to carry lightning currents of the outer conductor of the coaxial cable.

General Recommendations for Protection Installation

- In order to achieve the full performance of a protection circuit the application of good - practice EMC design techniques is necessary for the whole system to be protected.
- For EMP - protection usually a shield as an electromagnetic barrier to protect a certain volume is necessary. This shield avoids coupling of radiated disturbances inside the protected volume. In addition to shielding all penetrating wires must be protected from conducted transient interferences by an appropriate POE (point of entry) protection.
- Use tested, high quality POE (point of entry) protection elements for all wires entering an electromagnetic shield and install these as feed - through devices, e.g. the Meteolabor USS-1, USS-2, USP, or PLP series.

Ordering Information / Part Number

CSP-42201 RF EMP surge protector N75 (f)



Caution

Do not mate N75 connector with 50 Ohms N - connector (thicker inner pin) as this will result in permanent damage to the device!



Caution

Always keep Gas Discharge Tube (GDT) inserted. Removal of GDT will result in loss of protection.

Contact

Meteolabor AG
Hofstrasse 92
CH-8620 Wetzikon
Switzerland

Tel: +41 44 934 40 40
E-Mail: info@meteolabor.ch
Internet: www.meteolabor.ch

© by Meteolabor AG
All rights reserved

Content may change without further notice 2023-07
CSP-42201_e_V2023



RF EMP Protector DC – 1 GHz, 300W, N – N Jack CSP-43101

Protection for 50 Ohm coaxial cables based on Gas Discharge Tube (GDT) technology

Equipped with GDT for RF-power up to 300 W

Broad band, low loss operation from DC to 1 GHz

N-jack (female) for Input and Output

Feed-through installation into wall of Faraday cage or metallic housing

Protects against overvoltages produced by NEMP / HEMP, lightning or other transients

High surge current capability



Product

The Meteolabor CSP series RF EMP protectors are specially designed for the protection of coaxial lines. Surge currents up to 20 kA or single strikes up to 30 kA can be handled.

A unique mechanical bulkhead design offers easy feed-through installation and compact fitting into Faraday cages, shielded rooms and mechanical enclosures. Single point of entry concepts can be simply realised. This allows clear separation of unprotected and protected side.

Various transient protection designs for broadband or limited frequency band operation are available. Generally limited frequency band elements provide lower residual energy in the case of transient overvoltages such as produced by atmospheric discharges (lightning, electrostatic discharge) or a High Altitude Electro-Magnetic Pulse (HEMP), sometimes also referred to as NEMP.

Applications

The Meteolabor CSP-43101 RF EMP surge protector element ensures best protection of a broadband 50 Ohm coaxial line of telecommunication equipment etc. against transient overvoltages (e.g. NEMP / HEMP, lightning).

CSP-43101 is best suited for lines using N connectors and working with continuous power up to 300 W and various frequencies from 0 to 1 GHz.

Applications range from mission critical equipment, such as fixed or mobile military installations (e.g. C⁴I facilities) to civilian or industrial projects, requiring high reliability and state-of-the-art protection.

CSP-43101 has been successfully used in many projects, where HEMP-testing according to RS-105 on threat-level has been conducted

Technical Data CSP-43101

Application	50 Ohm coaxial line	For broadband applications DC – 1 GHz, max. 300 W
Standards	IEC-61000-4-5	Compliant to categories 0-4
Max. operating power	300 W	With matched load, mismatch or higher power may trigger GDT
Max. surge current I_{Max}	25 kA	Inner conductor → ground, shape 8 / 20 μs, single pulse
Nominal surge current I_N	20 kA	Inner conductor → ground, shape 8 / 20 μs, 10 pulses at 30s intervals
Residual energy	700μJ typically	4 kV / 2 kA test pulse, current shape 8 / 20 μs, 50 Ohm load
Frequency range	0 to 1000 MHz	Insertion loss ≤ 0.1 dB
Return loss	≥ 26 dB	0 to 1000 MHz < 900 V
DC-spark-over voltage U_{Zstat}	350 V ±20%	Dynamic spark-over voltage $U_{Zdyn} = 875V$ at 1kV / μs typically
Connectors	N jack (female)	Unprotected and protected side
Operating temperature	-40°C to +85°C	
Ingress protection	IP 65	when coupled with conform mating connectors
Case material	Brass	Housing: nickel-free plating, center contacts: gold plating
Installation torque	Max. 20 Nm	Min. 15 Nm for good grounding contact
Dimensions	55.2 x ø 25.9 mm	Major dimensions, details see drawing
Weight	approx. 120 g	

Dimensions [mm]

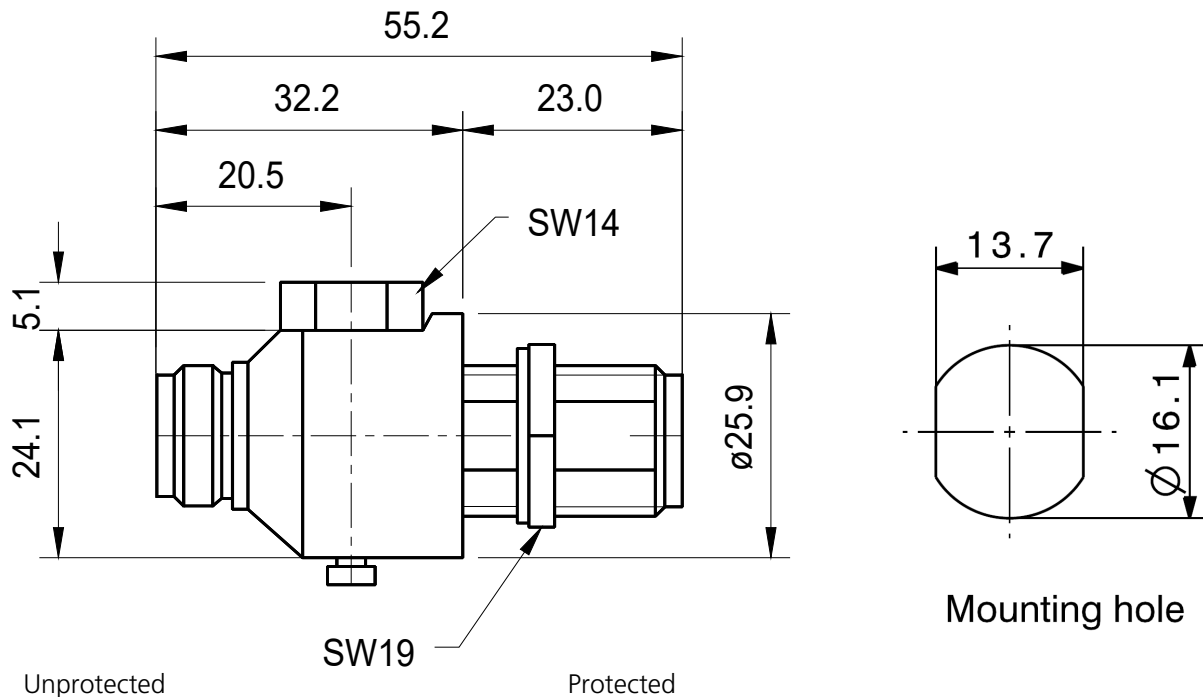

Installation Notes

- The CSP series EMP protectors shall be installed by electrically skilled personnel.
- The electrical wiring must be done according to local regulations.
- The max. values stated in this datasheet must not be exceeded under any circumstances.
- Do not exceed max. installation torque of 20 Nm as this can result in permanent damage.
- CSP series EMP protectors may be directly installed into the wall of a Faraday cage as feed-through device. If not used in a Faraday cage good and very short grounding (min. 16 mm²) is necessary to carry lightning currents of the outer conductor of the coaxial cable.

General Recommendations for Protection Installation

- In order to achieve the full performance of a protection circuit the application of good-practice EMC design techniques is necessary for the whole system to be protected.
- For EMP-protection usually a shield as an electromagnetic barrier to protect a certain volume is necessary. This shield avoids coupling of radiated disturbances inside the protected volume. In addition to shielding all penetrating wires must be protected from conducted transient interferences by an appropriate POE (point of entry) protection.
- Use tested, high quality POE (point of entry) protection elements for all wires entering an electromagnetic shield and install these as feed-through devices, e.g. the Meteolabor USS-1, USS-2, USP, or PLP series.

Ordering Information / Part Number

CSP-43101 RF EMP surge protector N (f)

**Caution**

Always keep Gas Discharge Tube (GDT) inserted.
Removal of GDT will result in loss of protection.

Contact

Meteolabor AG
Hofstrasse 92
CH-8620 Wetzikon
Switzerland

Tel: +41 44 934 40 40
E-Mail: info@meteolabor.ch
Internet: www.meteolabor.ch

© by Meteolabor AG
All rights reserved

Content may change without further notice 2023-07
CSP-43101_e_V2023



RF EMP Protector DC – 2.5 GHz, 300W, N – N Jack CSP-43102

Protection for 50 Ohm coaxial cables based on Gas Discharge Tube (GDT) technology

Equipped with GDT for RF-power up to 300 W

Broad band, low loss operation from DC to 2.5 GHz

N-jack (female) for Input and Output

Feed-through installation into wall of Faraday cage or metallic housing

Protects against overvoltages produced by NEMP / HEMP, lightning or other transients

High surge current capability



Product

The Meteolabor CSP series RF EMP protectors are specially designed for the protection of coaxial lines. Surge currents up to 20 kA or single strikes up to 25 kA can be handled.

A unique mechanical bulkhead design offers easy feed-through installation and compact fitting into Faraday cages, shielded rooms and mechanical enclosures. Single point of entry concepts can be simply realised. This allows clear separation of unprotected and protected side.

Various transient protection designs for broadband or limited frequency band operation are available. Generally limited frequency band elements provide lower residual energy in the case of transient overvoltages such as produced by atmospheric discharges (lightning, electrostatic discharge) or a High Altitude Electro-Magnetic Pulse (HEMP), sometimes also referred to as NEMP.

Applications

The Meteolabor CSP-43102 RF EMP surge protector element ensures best protection of a broadband 50 Ohm coaxial line of telecommunication equipment etc. against transient overvoltages (e.g. NEMP / HEMP, lightning).

CSP-43102 is best suited for lines using N connectors and working with continuous power up to 300 W and various frequencies from 0 to 2.5 GHz.

Applications range from mission critical equipment, such as fixed or mobile military installations to civilian or industrial projects, requiring high reliability and state-of-the-art protection.

CSP-43102 has been successfully used in many projects, where HEMP-testing according to RS-105 on threat-level has been conducted.

Technical Data CSP-43102

Application	50 Ohm coaxial line	For broadband applications DC – 2.5 GHz
Standards	IEC-61000-4-5	Compliant to categories 0-4
Max. operating power	300 W	With matched load, mismatch or higher power may trigger GDT
Max. surge current I_{Max}	25 kA	Inner conductor → ground, shape 8 / 20 μ s, single pulse
Nominal surge current I_N	20 kA	Inner conductor → ground, shape 8 / 20 μ s, 10 pulses at 30s intervals
Residual energy	350 μ J typically	4 kV / 2 kA test pulse, current shape 8 / 20 μ s, 50 Ohm load
Frequency range	0 to 2500 MHz	Insertion loss \leq 0.2 dB
Return loss	\geq 20 dB	0 to 2500 MHz
DC-spark-over voltage U_{Zstat}	350 V \pm 20%	Dynamic spark-over voltage U_{Zdyn} = 900 V at 1kV/ μ s typically
Connectors	N jack (female)	Unprotected and protected side
Operating temperature	-40°C to +85°C	
Ingress protection	IP 66	when coupled with conform mating connectors
Case material	Brass	Housing: nickel-free plating, center contacts: gold plating
Installation torque	Max. 20 Nm	Min. 15 Nm for good grounding contact
Dimensions	69 x \varnothing 25.9 mm	Major dimensions, details see drawing
Weight	approx. 130 g	

Dimensions [mm]

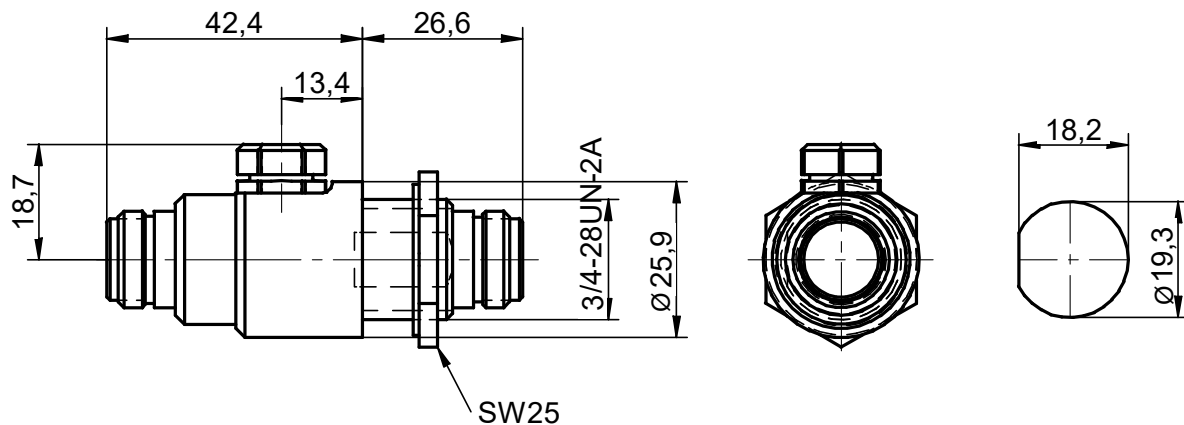

Unprotected

Protected

Installation Notes

- The CSP series EMP protectors shall be installed by electrically skilled personnel.
- The electrical wiring must be done according to local regulations.
- The max. values stated in this datasheet must not be exceeded under any circumstances.
- Do not exceed max. installation torque of 20 Nm as this can result in permanent damage.
- CSP series EMP protectors may be directly installed into the wall of a Faraday cage as feed-through device. If not used in a Faraday cage good and very short grounding (min. 16 mm²) is necessary to carry lightning currents of the outer conductor of the coaxial cable.

General Recommendations for Protection Installation

- In order to achieve the full performance of a protection circuit the application of good-practice EMC design techniques is necessary for the whole system to be protected.
- For EMP-protection usually a shield as an electromagnetic barrier to protect a certain volume is necessary. This shield avoids coupling of radiated disturbances inside the protected volume. In addition to shielding all penetrating wires must be protected from conducted transient interferences by an appropriate POE (point of entry) protection.
- Use tested, high quality POE (point of entry) protection elements for all wires entering an electromagnetic shield and install these as feed-through devices, e.g. the Meteolabor USS-1, USS-2, USP, or PLP series.

Ordering Information / Part Number

CSP-43102 RF EMP surge protector N(f)



Caution

Always keep Gas Discharge Tube (GDT) inserted.
Removal of GDT will result in loss of protection.

Contact

Meteolabor AG
Hofstrasse 92
CH-8620 Wetzikon
Switzerland

Tel: +41 44 934 40 40
E-Mail: info@meteolabor.ch
Internet: www.meteolabor.ch

© by Meteolabor AG
All rights reserved

Content may change without further notice 2023-07
CSP-43102_e_V2023

RF EMP Protector DC – 2000 MHz, 150 W, N75 – N75 CSP-44201

Protection for 75 Ohm coaxial cables based on Gas Discharge Tube (GDT) technology

Equipped with GDT for RF-power up to 150 W

Broad band, low loss operation from DC to 2 GHz

N75 - jack (female) for Input and Output

Feed - through installation into wall of Faraday cage or metallic housing

Protects against overvoltages produced by NEMP / HEMP, lightning or other transients

High surge current capability



The Meteolabor CSP series RF EMP protectors are specially designed for the protection of coaxial lines. Depending on model, nominal surge currents up to 20 kA or single strikes up to 30 kA can be handled.

A unique mechanical bulkhead design offers easy feed-through installation and compact fitting into Faraday cages, shielded rooms and mechanical enclosures. Single point of entry concepts can be simply realised. This allows clear separation of unprotected and protected side.

Various transient protection designs for broadband or limited frequency band operation are available. Generally limited frequency band elements provide lower residual energy in the case of transient overvoltages such as produced by atmospheric discharges (lightning, electrostatic discharge) or a High Altitude Electro-Magnetic Pulse (HEMP), sometimes also referred to as NEMP.

Applications

The Meteolabor CSP-44201 RF EMP surge protector element ensures best protection of a broadband 75 Ohm coaxial line of telecommunication equipment etc. against transient overvoltages (e.g. NEMP / HEMP, lightning).

CSP-44201 is best suited for lines using N75 connectors and working with continuous power up to 150 W and various frequencies from 0 to 2 GHz.

Applications range from mission critical equipment, such as fixed or mobile military installations (e.g. C4I facilities) to civilian or industrial projects, requiring high reliability and state-of-the-art protection.

CSP-44201 has been successfully used in many projects, where HEMP - testing according to RS - 105 on threat-level has been conducted.

Technical Data CSP-44201

Application	75 Ohm coaxial line	For broadband applications DC – 2 GHz, max. 100 W
Standards	IEC-61000-4-5	Compliant to categories 0-4
Max. operating power	150 W	With matched load; mismatch or higher power may trigger GDT
Max. surge current I_{Max}	25 kA	Inner conductor → ground, shape 8 / 20 μ s, single pulse
Nominal surge current I_N	20 kA	Inner conductor → ground, shape 8 / 20 μ s, 10 pulses at 30s intervals
Residual energy	350 μ J typically	4 kV / 2 kA test pulse, current shape 8 / 20 μ s, 75 Ohms load
Frequency range	0 to 2000 MHz	Insertion loss \leq 0.2 dB
Return loss	\geq 15 dB	0 to 2000 MHz; \geq 16.5 dB from 0 to 1500 MHz
DC-spark-over voltage U_{Zstat}	350 V \pm 20 %	Dynamic spark-over voltage U_{Zdyn} = 900 V at 1 kV/ μ s typically
Connectors	N 75 jack (female)	Unprotected and protected side; Caution: do not mate with 50 Ohms!
Operating temperature	-40°C to +85°C	
Ingress protection	IP 65	when coupled with conform mating connectors
Case material	Brass	Nickel plating; center contacts: gold plating
Installation torque	Max. 20 Nm	Min. 15 Nm recommended for good grounding contact
Dimensions	69 x \varnothing 25.9 mm	Major dimensions, details see drawing
Weight	approx. 140 g	

Dimensions [mm]

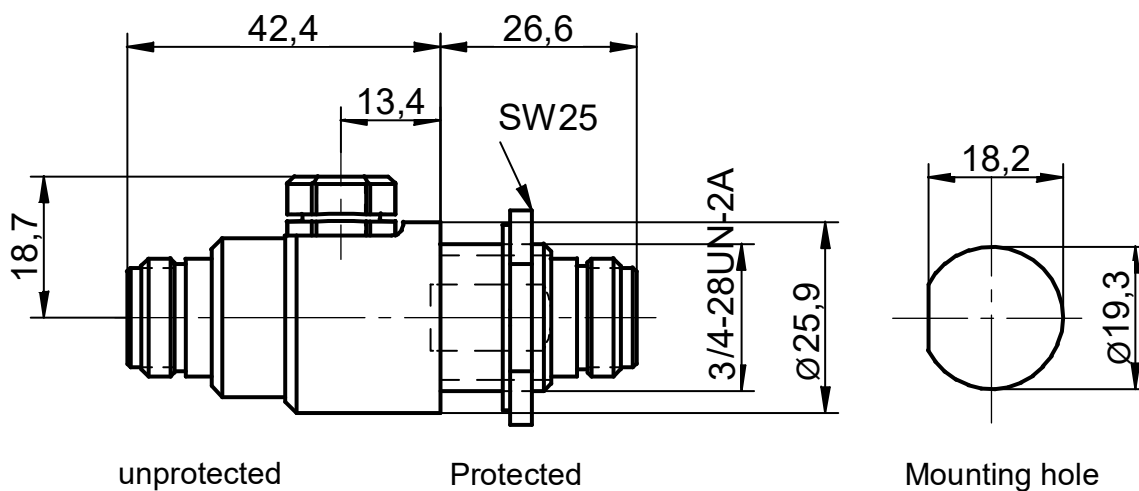

Installation Notes

- The CSP series EMP protectors shall be installed by electrically skilled personnel.
- The electrical wiring must be done according to local regulations.
- The max. values stated in this datasheet must not be exceeded under any circumstances.
- Do not exceed max. installation torque of 20 Nm as this can result in permanent damage.
- CSP series EMP protectors may be directly installed into the electrically conducting wall of a Faraday cage as feed-through device. If not used in a Faraday cage good and very short grounding (min. 16 mm²) is necessary to carry lightning currents of the outer conductor of the coaxial cable.

General Recommendations for Protection Installation

- In order to achieve the full performance of a protection circuit the application of good - practice EMC design techniques is necessary for the whole system to be protected.
- For EMP - protection usually a shield as an electromagnetic barrier to protect a certain volume is necessary. This shield avoids coupling of radiated disturbances inside the protected volume. In addition to shielding all penetrating wires must be protected from conducted transient interferences by an appropriate POE (point of entry) protection.
- Use tested, high quality POE (point of entry) protection elements for all wires entering an electromagnetic shield and install these as feed - through devices, e.g. the Meteolabor USS-1, USS-2, USP, or PLP series.

Ordering Information / Part Number

CSP-44201 RF EMP surge protector N75 (f)



Caution

Do not mate N75 connector with 50 Ohms N - connector (thicker inner pin) as this will result in permanent damage to the device!



Caution

Always keep Gas Discharge Tube (GDT) inserted. Removal of GDT will result in loss of protection.

Contact

Meteolabor AG
Hofstrasse 92
CH-8620 Wetzikon
Switzerland

Tel: +41 44 934 40 40
E-Mail: info@meteolabor.ch
Internet: www.meteolabor.ch

© by Meteolabor AG
All rights reserved

Content may change without further notice 2023-07
CSP-44201_e_V2023



RF EMP Protector DC – 1 GHz, 700W, N – N Jack CSP-47101

Protection for 50 Ohm coaxial cables based on Gas Discharge Tube (GDT) technology

Equipped with GDT for RF - power up to 700 W

Broad band, low loss operation from DC to 1 GHz

N-jack (female) for Input and Output

Feed-through installation into wall of Faraday cage or metallic housing

Protects against overvoltages produced by NEMP / HEMP, lightning or other transients

High surge current capability



Product

The Meteolabor CSP series RF EMP protectors are specially designed for the protection of coaxial lines. Surge currents up to 20 kA or single strikes up to 30 kA can be handled.

A unique mechanical bulkhead design offers easy feed-through installation and compact fitting into Faraday cages, shielded rooms and mechanical enclosures. Single point of entry concepts can be simply realised. This allows clear separation of unprotected and protected side.

Various transient protection designs for broadband or limited frequency band operation are available. Generally limited frequency band elements provide lower residual energy in the case of transient overvoltages such as produced by atmospheric discharges (lightning, electrostatic discharge) or a High Altitude Electro-Magnetic Pulse (HEMP), sometimes also referred to as Nuclear Electro-Magnetic Pulse (NEMP) or simply EMP.

Applications

The Meteolabor CSP-47101 RF EMP surge protector element ensures best protection of a broadband 50 Ohm coaxial line of telecommunication equipment etc. against transient overvoltages (e.g. NEMP / HEMP, lightning).

CSP-47101 is best suited for lines using N connectors and working with continuous power up to 700 W and various frequencies from 0 to 1 GHz.

Applications range from mission critical equipment, such as fixed or mobile military installations (e.g. C4I facilities) to civilian or industrial projects, requiring high reliability and state-of-the-art protection.

CSP-47101 has been successfully used in many projects, where HEMP-testing according to RS - 105 on threat-level has been conducted

Technical Data CSP-47101

Application	50 Ohm coaxial line	For broadband applications DC – 1 GHz, max. 700 W
Max. operating power	700 W	With matched load, mismatch or higher power may trigger GDT
Max. surge current I_{Max}	30 kA	Inner conductor → ground, shape 8 / 20 μ s, single pulse
Nominal surge current I_N	20 kA	Inner conductor → ground, shape 8 / 20 μ s, 10 pulses at 30s intervals
Residual energy	900 μ J typically	4 kV / 2 kA test pulse, current shape 8 / 20 μ s, 50 Ohm load
Frequency range	0 to 1000 MHz	Insertion loss \leq 0.1 dB
Return loss	\geq 26 dB	0 to 1000 MHz
DC-spark-over voltage U_{Zstat}	470 V \pm 20%	Dynamic spark-over voltage U_{Zdyn} = 1000V at 1 kV/ μ s typically
Connectors	N jack (female)	Unprotected and protected side
Operating temperature	-40°C to +85°C	
Ingress protection	IP 65	when coupled with conform mating connectors
Case material	Brass	Housing: nickel-free plating, center contacts: gold plating
Installation torque	Max. 20 Nm	Min. 15 Nm for good grounding contact
Dimensions	55.2 x \varnothing 25.9 mm	Major dimensions, details see drawing
Weight	approx. 120 g	

Dimensions [mm]

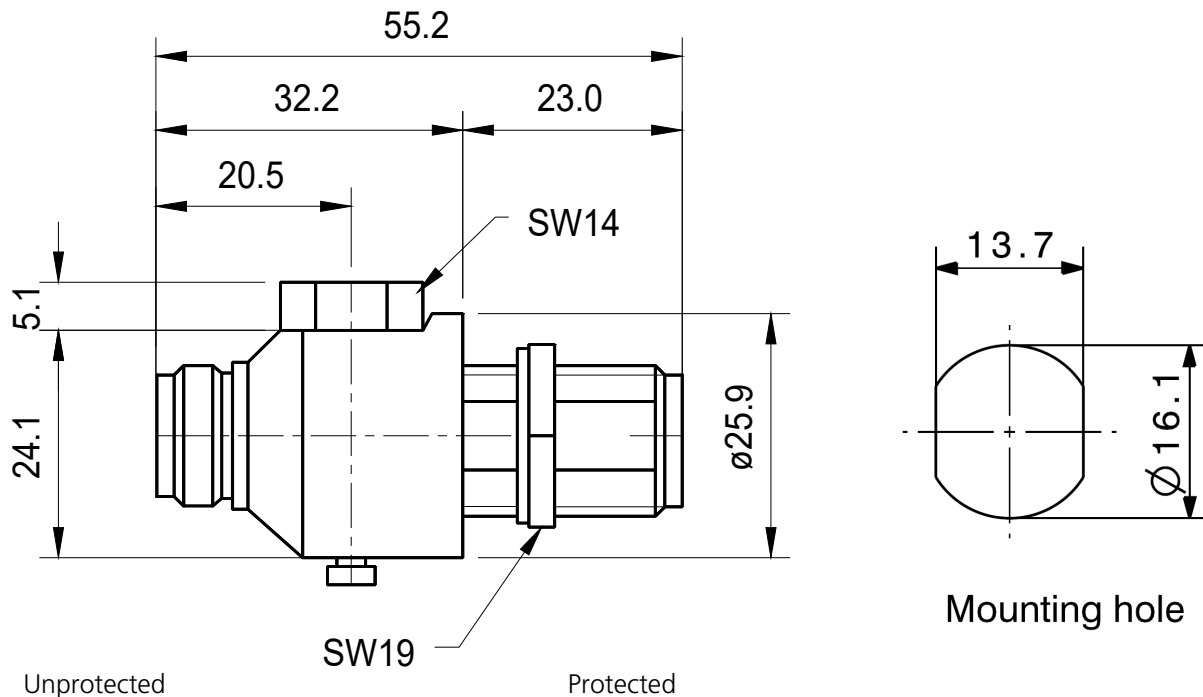

Installation Notes

- The CSP series EMP protectors shall be installed by electrically skilled personnel.
- The electrical wiring must be done according to local regulations.
- The max. values stated in this datasheet must not be exceeded under any circumstances.
- Do not exceed max. installation torque of 20 Nm as this can result in permanent damage.
- CSP series EMP protectors may be directly installed into the wall of a Faraday cage as feed-through device. If not used in a Faraday cage good and very short grounding (min. 16 mm²) is necessary to carry lightning currents of the outer conductor of the coaxial cable.

General Recommendations for Protection Installation

- In order to achieve the full performance of a protection circuit the application of good-practice EMC design techniques is necessary for the whole system to be protected.
- For EMP-protection usually a shield as an electromagnetic barrier to protect a certain volume is necessary. This shield avoids coupling of radiated disturbances inside the protected volume. In addition to shielding all penetrating wires must be protected from conducted transient interferences by an appropriate POE (point of entry) protection.
- Use tested, high quality POE (point of entry) protection elements for all wires entering an electromagnetic shield and install these as feed-through devices, e.g. the Meteolabor USS-1, USS-2, USP, or PLP series.

Ordering Information / Part Number

CSP-47101 RF EMP surge protector N(f)

**Caution**

Always keep Gas Discharge Tube (GDT) inserted.
Removal of GDT will result in loss of protection.

Contact

Meteolabor AG
Hofstrasse 92
CH-8620 Wetzikon
Switzerland

Tel: +41 44 934 40 40
E-Mail: info@meteolabor.ch
Internet: www.meteolabor.ch

© by Meteolabor AG
All rights reserved

Content may change without further notice 2023-07
CSP-47101_e_V2027

RF EMP Protector 806 – 2500 MHz, 500W, N – N Jack CSP-55101

Protection for 50 Ohm coaxial cables, based on High Pass Filter Technology

For RF - power up to 500 W

Low insertion loss operation from 806 to 2500 MHz

N - jack (female) for Input and Output

Feed-through installation into wall of Faraday cage or metallic housing

Very low residual energy protection against overvoltages produced by NEMP / HEMP, lightning or other transients

High surge current capability



Product

The Meteolabor CSP series RF EMP protectors are specially designed for the protection of coaxial lines. Surge currents up to 20 kA or single strikes up to 25 kA on the inner conductor can be handled.

A unique mechanical bulkhead design offers easy feed-through installation and compact fitting into Faraday cages, shielded rooms and mechanical enclosures. Single point of entry concepts can be simply realised. This allows clear separation of unprotected and protected side.

Various transient protection designs for broadband or limited frequency band operation are available. Generally limited frequency band elements provide lower residual energy in the case of transient overvoltages such as produced by atmospheric discharges (lightning, electrostatic discharge) or a High Altitude Electro-Magnetic Pulse (HEMP), sometimes also referred to as Nuclear Electro-Magnetic Pulse (NEMP) or simply EMP.

Applications

The Meteolabor CSP-55101 RF EMP surge protector element ensures best protection of a broadband 50 Ohm coaxial line of telecommunication equipment etc. against transient overvoltages (e.g. NEMP / HEMP, lightning).

CSP-55101 is best suited for lines using N connectors, working with RF - power up to 500 W in the frequency range from 806 to 2500 MHz.

Applications range from mission critical equipment, such as fixed or mobile military installations (e.g. C4I facilities) to civilian or industrial projects, requiring high reliability and state-of-the-art protection.

CSP-55101 has been successfully used in many projects, where HEMP-testing according to RS - 105 on threat-level has been conducted

Technical Data CSP-55101

Application	50 Ohm coaxial line	For RF applications 806 – 2500 MHz, max. 500 W
Max. operating power	500 W	Matched load
Max. surge current I_{Max}	25 kA	Inner conductor → ground, shape 8 / 20 μ s, single pulse
Nominal surge current I_N	20 kA	Inner conductor → ground, shape 8 / 20 μ s, 10 pulses at 30s intervals
Residual energy	0.03 μ J typically	4 kV / 2 kA test pulse, current shape 8 / 20 μ s, 50 Ohm load
Frequency range	806 to 2500 MHz	Insertion loss \leq 0.1 dB
Return loss	\geq 26 dB	806 to 2500 MHz
Connectors	N jack (female)	Unprotected and protected side
Operating temperature	-40°C to +85°C	
Ingress protection	IP 65	when coupled with conform mating connectors
Case material	Brass	Housing: nickel-free plating, center contacts: gold plating
Installation torque	Max. 35 Nm	Min. 30 Nm for good grounding contact
Dimensions	97.2 x \varnothing 39.6 mm	Major dimensions, details see drawing
Weight	approx. 500 g	

Dimensions [mm]

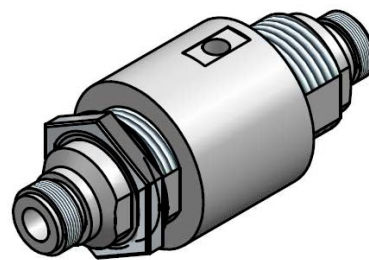
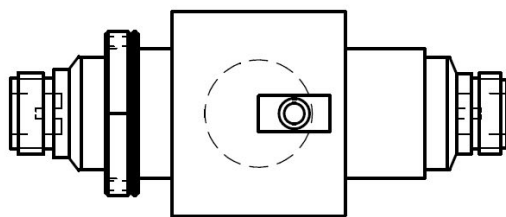
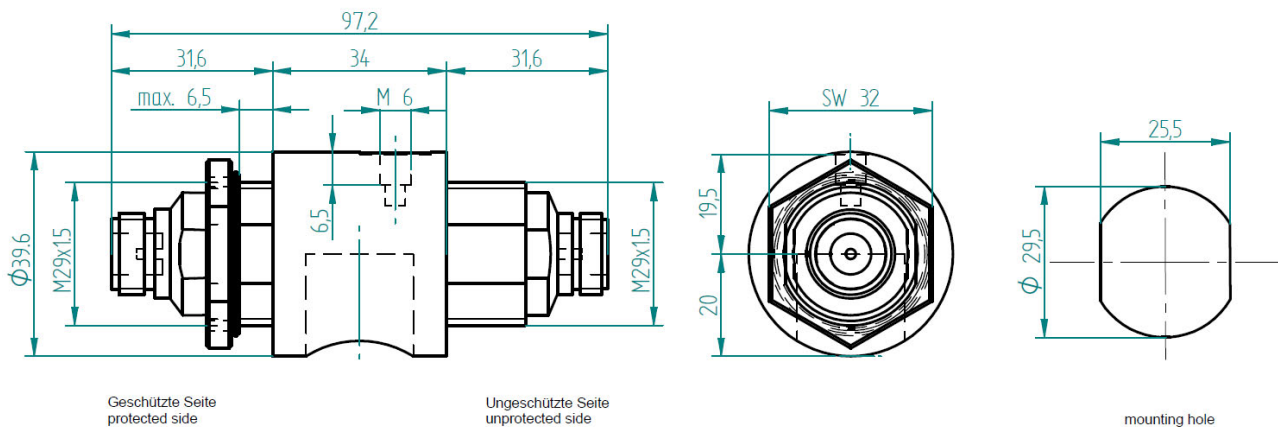

Installation Notes

- The CSP series EMP protectors shall be installed by electrically skilled personnel.
- The electrical wiring must be done according to local regulations.
- The max. values stated in this datasheet must not be exceeded under any circumstances.
- Do not exceed max. installation torque of 35 Nm as this can result in permanent damage.
- CSP series EMP protectors may be directly installed into the wall of a Faraday cage as feed-through device. If not used in a Faraday cage good and very short grounding (min. 16mm²) is necessary to carry lightning currents of the outer conductor of the coaxial cable.
- Note that unprotected / protected side must be installed accordingly.

General Recommendations for Protection Installation

- In order to achieve the full performance of a protection circuit the application of good-practice EMC design techniques is necessary for the whole system to be protected.
- For EMP-protection usually a shield as an electromagnetic barrier to protect a certain volume is necessary. This shield avoids coupling of radiated disturbances inside the protected volume. In addition to shielding all penetrating wires must be protected from conducted transient interferences by an appropriate POE (point of entry) protection.
- Use tested, high quality POE (point of entry) protection elements for all wires entering an electromagnetic shield and install these as feed-through devices, e.g. the Meteolabor® USS-1, USS-2, USP, or PLP series.

Ordering Information / Part Number

CSP-55101 RF EMP surge protector N(f)



Caution

For proper function unprotected / protected side must be installed correctly.

Contact

Meteolabor AG
Hofstrasse 92
CH-8620 Wetzikon
Switzerland

Tel: +41 44 934 40 40
E-Mail: info@meteolabor.ch
Internet: www.meteolabor.ch

© by Meteolabor AG
All rights reserved

Content may change without further notice 2023-07
CSP-55101_e_V2023



RF EMP Protector 6 – 18 GHz, 100 W, N -N Jack CSP-62101

Protection for 50 Ohm coaxial cables based on Gas Discharge Tube (GDT) technology

Equipped with GDT for RF-power up to 100 W

Broad band, low loss operation from 6 to 18 GHz

N jack (female) for Input and Output

Feed-through installation into wall of Faraday cage or metallic housing

Protects against overvoltages produced by NEMP / HEMP, lightning or other transients

High surge current capability



Product

The Meteolabor CSP series RF EMP protectors are specially designed for the protection of coaxial lines. Surge currents up to 20 kA or single strikes up to 30 kA can be handled.

A unique mechanical bulkhead design offers easy feed-through installation and compact fitting into Faraday cages, shielded rooms and mechanical enclosures. Single point of entry concepts can be simply realised. This allows clear separation of unprotected and protected side.

Various transient protection designs for broadband or limited frequency band operation are available. Generally limited frequency band elements provide lower residual energy in the case of transient overvoltages such as produced by atmospheric discharges (lightning, electrostatic discharge) or a High Altitude Electro-Magnetic Pulse (HEMP), sometimes also referred to as Nuclear Electro-Magnetic Pulse (NEMP) or simply EMP.

Applications

The Meteolabor CSP-62101 RF EMP surge protector element ensures best protection of a broadband 50 Ohm coaxial line of telecommunication equipment etc. against transient overvoltages (e.g. NEMP / HEMP, lightning).

CSP-62101 is best suited for lines using BNC connectors and working with continuous power up to 150 W and various frequencies from 0 to 1 GHz.

Applications range from mission critical equipment, such as fixed or mobile military installations (e.g. C⁴ facilities) to civilian or industrial projects, requiring high reliability and state-of-the-art protection.

CSP-62101 has been successfully used in many projects, where HEMP - testing according to RS - 105 on threat-level has been conducted

Technical Data CSP-62101

Application	50 Ohm coaxial line	For broadband applications DC – 1 GHz, max. 150 W
Nominal operating power	100 W	With matched load, mismatch or higher power may trigger GDT
Max. surge current I _{Max}	50 kA	Inner conductor → ground, shape 8 / 20 μs, single pulse
Residual energy	5 μJ typically	4 kV / 2 kA test pulse, current shape 8 / 20 μs, 50 Ohm load
Frequency range	6000 to 18000 MHz	Insertion loss ≤ 0.1 dB
Return loss	≥ 20 dB	0 to 1000 MHz; ≥ 26 dB 0 to 300 MHz
Connectors	N (female)	Unprotected and protected side
Operating temperature	-40°C to +85°C	
Ingress protection	IP 65	when coupled with conform mating connectors
Case material	Brass	Housing: nickel-free plating, center contacts: gold plating
Installation torque	Max. 20 Nm	Min. 15 Nm for good grounding contact
Dimensions	85.1 x ø 31.6 mm	Major dimensions, details see drawing
Weight	approx. 225 g	

Dimensions [mm]

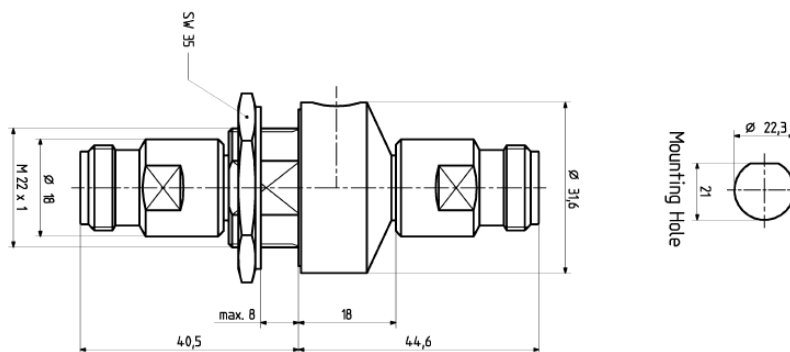

Installation Notes

- The CSP series EMP protectors shall be installed by electrically skilled personnel.
- The electrical wiring must be done according to local regulations.
- The max. values stated in this datasheet must not be exceeded under any circumstances.
- Do not exceed max. installation torque of 20 Nm as this can result in permanent damage.
- CSP series EMP protectors may be directly installed into the wall of a Faraday cage as feed-through device. If not used in a Faraday cage good and very short grounding (min. 16 mm²) is necessary to carry lightning currents of the outer conductor of the coaxial cable.

General Recommendations for Protection Installation

- In order to achieve the full performance of a protection circuit the application of good-practice EMC design techniques is necessary for the whole system to be protected.
- For EMP-protection usually a shield as an electromagnetic barrier to protect a certain volume is necessary. This shield avoids coupling of radiated disturbances inside the protected volume. In addition to shielding all penetrating wires must be protected from conducted transient interferences by an appropriate POE (point of entry) protection.
- Use tested, high quality POE (point of entry) protection elements for all wires entering an electromagnetic shield and install these as feed-through devices, e.g. the Meteolabor USS-1, USS-2, USP, or PLP series.

Ordering Information / Part Number

CSP-62101 RF EMP surge protector BNC (f)



Caution

Always keep Gas Discharge Tube (GDT) inserted.
Removal of GDT will result in loss of protection.

Contact

Meteolabor AG
Hofstrasse 92
CH-8620 Wetzikon
Switzerland

Tel: +41 44 934 40 40
E-Mail: info@meteolabor.ch
Internet: www.meteolabor.ch

© by Meteolabor AG
All rights reserved

Content may change without further notice 2023
CSP-62101_e_V2023



RF EMP Protector 2 – 6 GHz, 300 W, N – N Jack CSP-73101

Protection for 50 Ohm coaxial cables, based on quarter wave stub technology

For RF-power up to 300 W

Low insertion loss operation from 2 to 6 GHz

N - jack (female) for Input and Output

Feed-through installation into wall of Faraday cage or metallic housing

Very low residual energy protection against overvoltages produced by NEMP / HEMP, lightning or other transients

High surge current capability



Product

The Meteolabor CSP series RF EMP protectors are specially designed for the protection of coaxial lines. High surge currents on the inner conductor can be handled.

A unique mechanical bulkhead design offers easy feed-through installation and compact fitting into Faraday cages, shielded rooms and mechanical enclosures. Single point of entry concepts can be simply realised. This allows clear separation of unprotected and protected side.

Various transient protection designs for broadband or limited frequency band operation are available. Generally limited frequency band elements provide lower residual energy in the case of transient overvoltages such as produced by atmospheric discharges (lightning, electrostatic discharge) or a High Altitude Electro-Magnetic Pulse (HEMP), sometimes also referred to as Nuclear Electro-Magnetic Pulse (NEMP) or simply EMP.

Applications

The Meteolabor CSP-73101 RF EMP surge protector element ensures best protection of a broadband 50 Ohm coaxial line of telecommunication equipment etc. against transient overvoltages (e.g. NEMP / HEMP, lightning).

CSP-73101 is best suited for lines using N connectors, working with RF - power up to 300 W in the frequency range from 2000 to 6000 MHz.

Applications range from mission critical equipment, such as fixed or mobile military installations (e.g. C4I facilities) to civilian or industrial projects, requiring high reliability and state-of-the-art protection.

CSP-73101 has been successfully used in many projects, where HEMP - testing according to RS-105 on threat-level has been conducted

Technical Data CSP-73101

Application	50 Ohm coaxial line	For RF applications 2 – 6 GHz, max. 300 W
Max. operating power	300 W	Matched load
Max. surge current I_{Max}	50 kA	Inner conductor → ground, shape 8 / 20 μ s, multiple pulse
Residual energy	0.4 μ J typically	4 kV / 2 kA test pulse, current shape 8 / 20 μ s, 50 Ohm load
Frequency range	2000 to 6000 MHz	Insertion loss \leq 0.2 dB
Return loss	\geq 20 dB	2000 to 6000 MHz
Connectors	N jack (female)	Unprotected and protected side
Operating temperature	-40°C to +70°C	
Ingress protection	IP 65	when coupled with conform mating connectors
Case material	Brass	Housing: nickel-free plating, center contacts: gold plating
Installation torque	Max. 20 Nm	Min. 15 Nm for good grounding contact
Dimensions	126 x 55 x \varnothing 24 mm	Major dimensions, details see drawing
Weight	approx. 300 g	

Dimensions [mm]

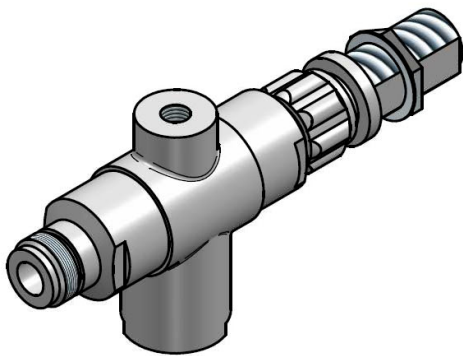
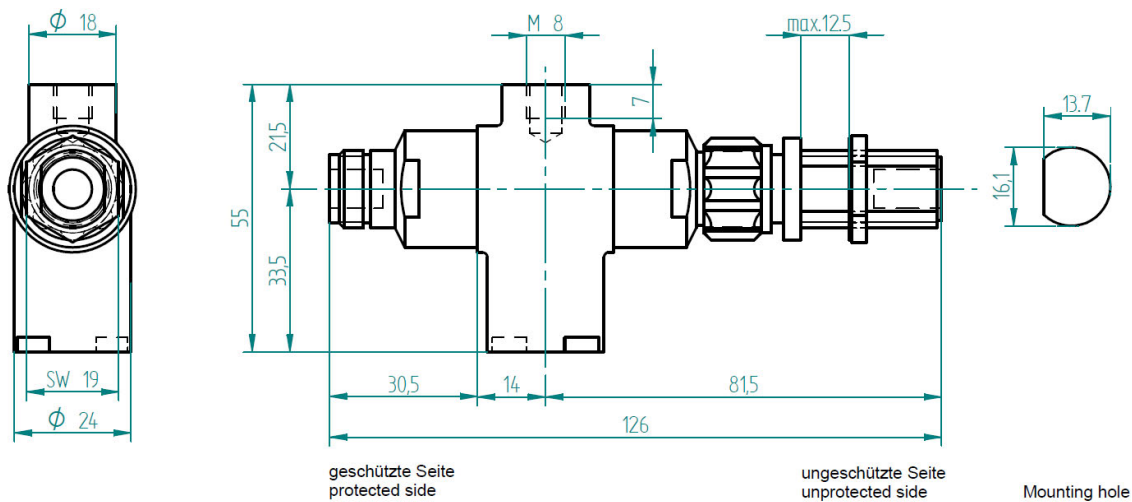

Installation Notes

- The CSP series EMP protectors shall be installed by electrically skilled personnel.
- The electrical wiring must be done according to local regulations.
- The max. values stated in this datasheet must not be exceeded under any circumstances.
- Do not exceed max. installation torque of 20 Nm as this can result in permanent damage.
- CSP series EMP protectors may be directly installed into the wall of a Faraday cage as feed-through device. If not used in a Faraday cage good and very short grounding (min. 16 mm²) is necessary to carry lightning currents of the outer conductor of the coaxial cable.

CSP-73101 is electrically symmetric and can be placed inside or outside of the wall.

Ordering Information / Part Number

CSP-73101 RF EMP surge protector N(f)

General Recommendations for Protection Installation

- In order to achieve the full performance of a protection circuit the application of good-practice EMC design techniques is necessary for the whole system to be protected.
- For EMP - protection usually a shield as an electromagnetic barrier to protect a certain volume is necessary. This shield avoids coupling of radiated disturbances inside the protected volume. In addition to shielding all penetrating wires must be protected from conducted transient interferences by an appropriate POE (point of entry) protection.
- Use tested, high quality POE (point of entry) protection elements for all wires entering an electromagnetic shield and install these as feed-through devices, e.g. the Meteolabor USS-1, USS-2, USP, or PLP series.



Caution

This protector blocks low frequencies and therefore any DC voltage will be short-circuited.

Contact

Meteolabor AG
Hofstrasse 92
CH-8620 Wetzikon
Switzerland

Tel: +41 44 934 40 40
E-Mail: info@meteolabor.ch
Internet: www.meteolabor.ch

© by Meteolabor AG
All rights reserved

Content may change without further notice 2023-07
CSP-73101_e_V2023



RF EMP Protector DC + 650 – 2500 MHz, 50 W, N – N CSP-81101

Protection for 50 Ohm coaxial cables with protected DC-bypass up to max. 15 V / 3 A

For RF - power up to 50 W and DC for antenna powering

Low insertion loss operation from 650 to 2500 MHz

N - jack (female) for Input and Output

Feed-through installation into wall of Faraday cage or metallic housing

Very low residual energy protection against surges of NEMP / HEMP, lightning or other transients

High surge current capability



Product

The Meteolabor CSP series RF EMP protectors are specially designed for the protection of coaxial lines. High surge currents on the inner conductor can be handled. A unique mechanical bulkhead design offers easy feed-through installation and compact fitting into Faraday cages, shielded rooms and mechanical enclosures. Single point of entry concepts can be simply realised. This allows clear separation of unprotected and protected side.

Various transient protection designs for broadband or limited frequency band operation are available. Generally limited frequency band elements provide lower residual energy in the case of transient overvoltages such as produced by atmospheric discharges (lightning, electrostatic discharge) or a High Altitude Electro-Magnetic Pulse (HEMP), sometimes also referred to as Nuclear Electro-Magnetic Pulse (NEMP) or simply EMP.

Applications

The Meteolabor CSP-81101 RF EMP surge protector element ensures best protection against transient overvoltages (e.g. NEMP / HEMP, lightning) for a 50 Ohm coaxial line carrying operating frequencies in the range of 650 to 2500 MHz with max. RF-power up to 50 W and an additional DC-bypass.

CSP-81101 is best suited for lines using N connectors, a typical application example is an active GPS-antenna working with an amplifier DC-power supply up to max. 15 V / 3 A

CSP-81101 has been successfully used in many projects, where HEMP-testing according to RS-105 on threat-level has been conducted

Technical Data CSP-81101

Application	50 Ohm coaxial line	For DC + RF applications 650 – 2500 MHz, max. 50 W, 15 V DC / 3 A
Max. operating power	50 W	Matched load
Max. surge current I_{Max}	30 kA	Inner conductor → ground, shape 8 / 20 μ s, single pulse
Nominal surge current I_N	20 kA	Inner conductor → ground, shape 8 / 20 μ s, multiple pulses
Residual energy	6 μ J typically	4 kV / 2 kA test pulse, current shape 8 / 20 μ s, 50 Ohms load
Residual voltage	< \pm 25 V	4 kV / 2 kA test pulse, current shape 8 / 20 μ s, 50 Ohms load
Residual energy	5 μ J typically	Fast rising 4 kV, 5 / 50 ns test pulse, 50 Ohms load
Residual voltage	< \pm 30 V	Fast rising 4 kV, 5 / 50 ns test pulse, 50 Ohms load
Frequency range	650 to 2500 MHz	Insertion loss \leq 0.5 dB
Return loss	\geq 20 dB	650 to 2500 MHz
Connectors	N jack (female)	Unprotected and protected side
Operating temperature	-40°C to +85°C	
Ingress protection	IP 65	when coupled with conform mating connectors
Case material	Aluminium	Housing: chromated, center contacts: gold plating
Installation torque	Max. 20 Nm	Min. 15 Nm for good grounding contact
Dimensions	106 x 58 x 39 mm	Major dimensions, details see drawing
Weight	approx. 335 g	



NKF-Series
Lightning Protection
Blitz-Überspannungsschutz



Netzkommando-Sperrfilter NKF-2A

Net command blocking filter NKF-2A



Das Netzkommando - Sperrfilter dämpft Netzkommando- bzw. Rundsteuerfrequenzen von 600 Hz oder höher um mindestens 20 dB. Das Sperrfilter wird eingesetzt, um die hörbaren Rundsteuerfrequenzen auf nicht mehr störende Pegel zu reduzieren. Unerwünschte akustische Störungen können auftreten bei Phasenanschnittsteuerungen, in Tonstudios, bei Musik- und Videoanlagen oder Umwälzpumpen von Heizungsanlagen. Bei Lichtdimmern kann zusätzlich das Licht während den anliegenden Netzkommandos unangenehm flackern. Wird das Sperrfilter für Phasenanschnittsteuerungen eingesetzt, so ist zu berücksichtigen, dass die relativ grosse Induktivität der Filter den Stromanstieg verlangsamt. Übersteigt der periodische Spitzenstrom den doppelten Wert des maximal zulässigen Dauerstromes (Effektivwert), ist mit Problemen zu rechnen. Das Filter NKF-2A-DIN für max. 2 A ist in einem Kunststoffgehäuse eingegossen. Es ist in Blockform mit Anschlussdrähten aber auch als Version für DIN-Schienen-Montage lieferbar (offeriert wurde die Blockversion).

The net command blocking filter attenuates net command or ripple control frequencies of 600 Hz or higher by at least 20 dB. The blocking filter is used to reduce the audible ripple control frequencies to non-disturbing levels. Unwanted acoustic interferences can occur with phase controlled modulators, at sound studios, with music- and video equipment or with recirculating pumps of heating systems. Lights could flicker unpleasantly during the pending net commands, if you use light dimmer switches. If the blocking filter is used for phase controlled modulators, you must take into consideration that the relatively high inductance of the filter slows down the increase in current. Should the periodic peak current exceed double the value of the maximum allowed permanent current (effective value), problems can be expected. The filter NKF-2A-DIN for maximum 2 A is cast in a plastic case. It can be delivered as a block shaped version with connecting wires, but also as a version mountable on a DIN-bar (offered was the block version).

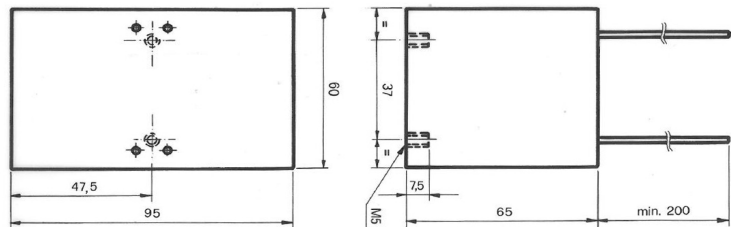



NKF-10A-LED Netzkommando-Sperrfilter Net Command Blocking Filter

Netzkommando-Sperrfilter für 10 A Strom.

Unterdrückt störende Netzkommando Signale, die moderne LED-Lampen oft zum Flackern bringen.

Net command blocking filter NKF-2A for 10 current

Suppresses disturbing network command signals that often cause modern LED lamps to flicker.



Anwendung

Die Netzkommando-Sperrfilter weisen für alle gebräuchlichen Netzkommando- oder Rundsteuerfrequenzen über 600 Hz eine Dämpfung von mindestens 15 dB auf. Sie werden dort eingesetzt, wo die von den Elektrizitätswerken für Steuerzwecke auf das Netz eingespeiste Tonfrequenzsignale auf nicht mehr störende Pegel reduziert werden müssen. Im Laufe der letzten Jahre lässt sich das immer mehr bei LED-Leuchten beobachten. Bei der Anwendung für Phasenanschnittsteuerungen ist zu beachten, dass die große Induktivität des Filter den Stromanstieg verlangsamt. Übersteigt der Einschalt- oder der periodische Spitzenstrom - den doppelten Wert des zulässigen Dauerstromes (Effektivwert), kann es sogar sein, dass das Filter eine aufschaukelnde Wirkung hat und damit seine Wirkung verliert.

Application

The network command blocking filters have an attenuation of at least 15 dB for all common network command or ripple control frequencies above 600 Hz. They are used where the audio frequency signals fed into the network by the power plants for control purposes have to be reduced to levels that are no longer disturbing. Over the past few years, this can be observed more and more with LED lights. When using phase control, it should be noted that the large inductance of the filter slows down the current rise. If the inrush or periodic peak current exceeds twice the permissible continuous current (rms value), the filter may even have a rocking effect and thus lose its effect.

Technische Daten NKF-10A-LED / Technical data NKF-10A-LED

Applikation / Application	Netzkommando-Unterdrückung (für LED-Beleuchtungen)
Nennspannung / Operating voltage	230 V
Betriebsspannung Max. / Max. voltage	250 V
Spannungserhöhung im Leerlauf / Voltage rise without load	14 V
Frequenzbereich / Frequency range	DC – 60 Hz.
Nennstrom / Operational current	10 A (T _a = 60° C.)
Gleichstromwiderstand beider Strompfade in Serie / Input resistance	0.15 Ω
Temperaturbereich / Temperature range	- 25°...+ 85° C
Prüfspannung L/N-E / Testvoltage L/N-E	2000 VAC / 2s
Prüfspannung L-N / Testvoltage L/N	1075 VAC / 2s
Klimaklasse nach DIN 40040 / Climate class DIN 40040	HPF
Gewicht / Weight	6.6 kg

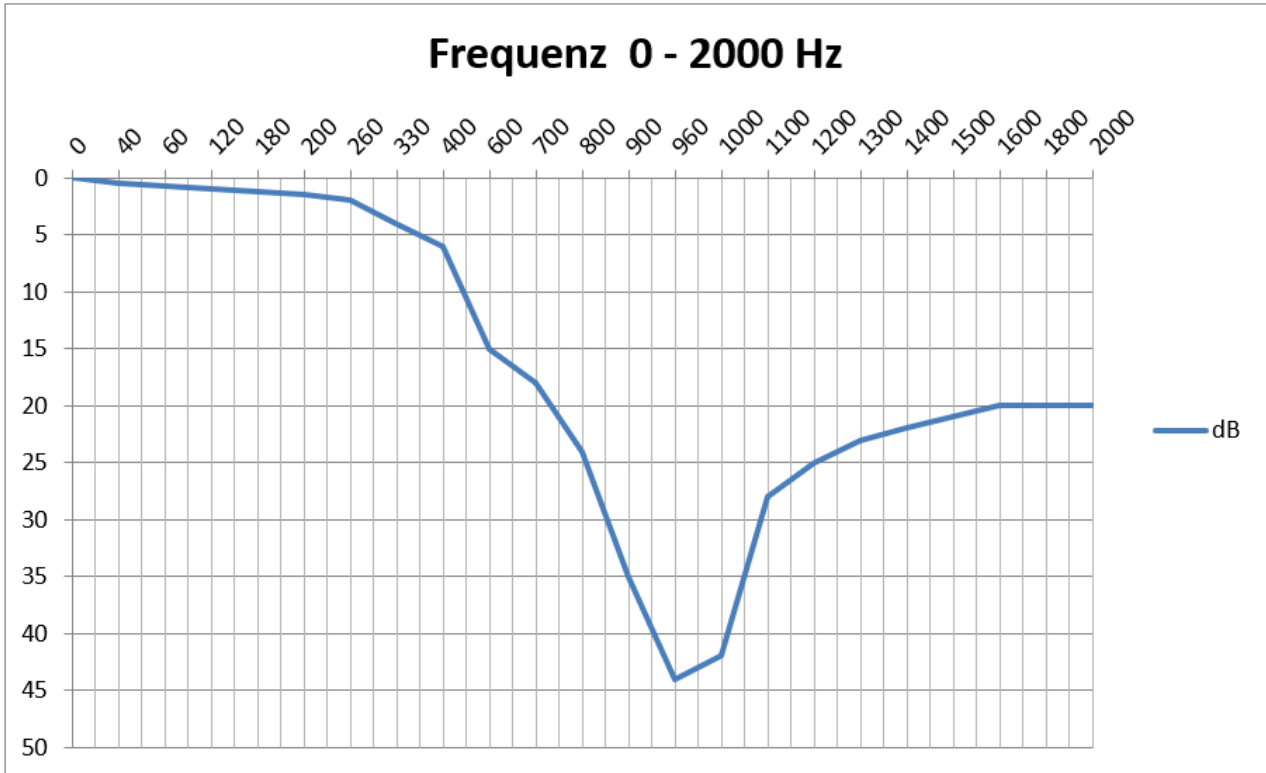

Dämpfungsverlauf 0 - 2000 Hz. / Insertion loss

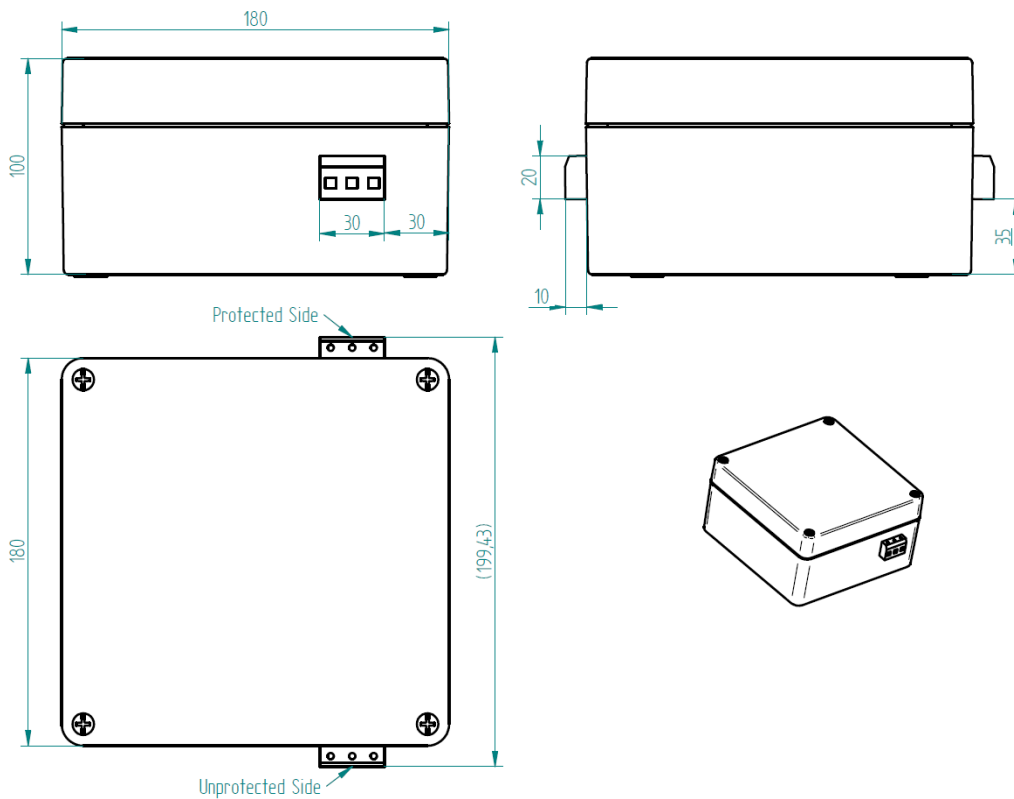

Massangaben in mm./ Dimensions in mm

Contact

Meteolabor AG
 Hofstrasse 92
 CH-8620 Wetzikon
 Switzerland

Phone: +41 44 934 40 40
 E-Mail: info@meteolabor.ch
 Internet: www.meteolabor.ch

© by Meteolabor AG
 All rights reserved.

Content may change without further notice • 2023-07
 NKF-10A-LED_d_e_V2023

